

# Gasifier for Damp Fuel

**Professor Harald Kyrklund,  
Helsinki, Finland  
(Translation 2000, Joacim Persson)**

**(From *Teknisk Tidskrift*, July 21 1945)**

Fluid fuels are so superior to producer gas that gaseous fuel for vehicles probably will be abandoned, if we gain free access to fluid fuel again, but the question is, when this will happen. We will probably have to resort to producer gas for years yet, at least for our trucks and busses, and even in the peace economy we will generate gas in our industry gasifiers. It is therefore fully motivated, that we maintain our interest in gasifier problems.

## Previous attempts with wet wood

On our side of the Bothnian Sea, development has taken us to the point now, that coal gas has almost entirely been replaced by wood gas. In this field, experience has also shown us, as for steam boiler furnaces and industry stoves, that it is generally economically more advantageous to use a fuel in raw, unrefined form, than converting it to a quality fuel, since the gain usually does not correspond to the complications and costs connected to the refining of it. But the transition from charcoal to wood gas is merely a half measure, as long as we have to use wood dried in an oven or at least fully air-dry wood, as for the present has been the case with all car gasifiers.

To free us from this inconvenience, a variety of methods has been resorted to. As the quality of producer gas primarily depends upon the temperature in the reaction zone, one has resorted to heat recapturing for improving quality, i.e. used heat from the produced gases, which is lost anyway, for heating the primary air versus pre-heating the fuel.

Heating primary air is in all circumstances correct, but pre-heating fuel can, as I will show here, lead to the quite opposite result of the wanted when applied to damp wood.

One way to raise the reaction temperature is to remove moisture from the fuel in advance by condensing the steam from the fuel in the container. With this in mind one has left the upper part of the fuel container unheated on most wood gasifiers, so that the mists can be condensed there and lead away to a separation vessel. The principle is correct, but previously it has not been applied in a consequent manner, and this circumstance, combined with an incorrectly applied pre-heating of the fuel has led to the situation that our wood gasifiers has not been able to work with damp fuel, and it has been the common view that this is not possible at all, at least not with car gasifiers.

---

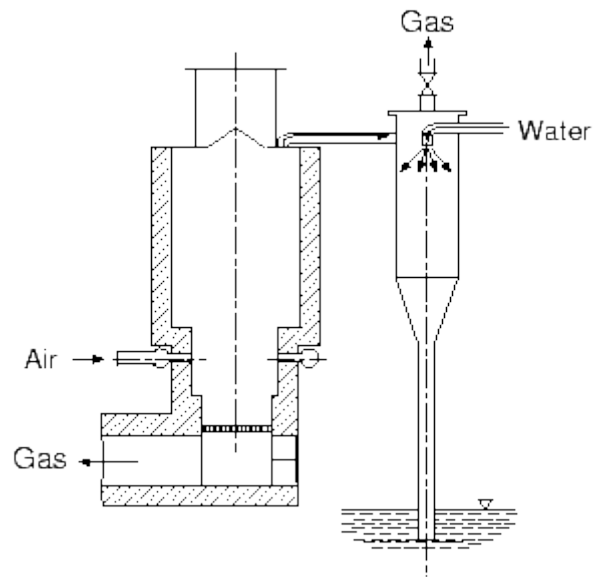

Figure 1: Gasifier at Outokumpu copper mill.

---

In many locations, hope has however not been abandoned that this 'impossibility' could be overcome. So, at Outokumpu copper mill at Vuoksenniska, a large, stationary, gasifier was built, working with overpressure (figure 1), where the fuel container was connected to a spray condenser, which efficiently sucked out the steam and dried the fuel in that manner. Completely wet wood were used, but the condenser had to be supplied with an adjustable valve, so that some permanent gases could be released, otherwise its condensing capacity would become insufficient and the quality of the gas too low.

---

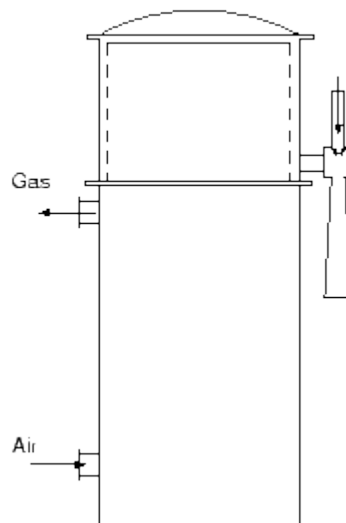

Figure 2: Drying of fuel with an ejector.

---

A few years ago, in the laboratory at the Institute of Technology in Helsinki, I also performed attempts to remove steam from a vehicle gasifier fuel container, using an ejector (figure 2). Exhaust gases from the motor were used as powering media. A significant improvement of gas quality could be observed during these tests. Unfortunately, some combustible gases were lost, which was avoided with the device suggested by dr. Lutz (figure 3).

---

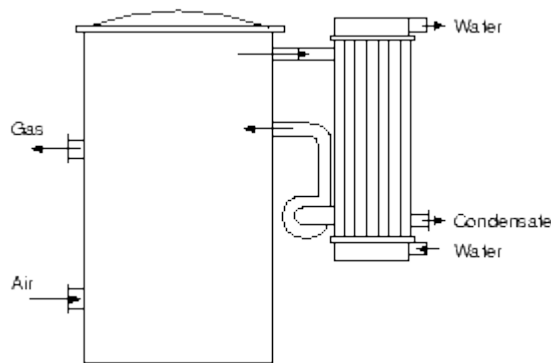

Figure 3: Drying device suggested by Lutz.

---

## The invention of the Monorator

A radical solution to the problem has however been found in the monorator, which to great extent has pure coincidence to thank for its birth. During experiments with gasifier trailers at the beginning of the present world war, the also in Sweden well known racing driver S P J Keinänen found, that to gain free sighting out the rear he had to make the gasifier's fuel container low, but in order to still have room for enough fuel he had to increase its width quite a lot. These primary conditions combined with the inventor's at the time incomplete knowledge of earlier existing gasifier designs, lead to a fuel container designed in a way which in several ways differed from the by Imbert created orthodox type, and so the monorator container was born (figure 4).

---

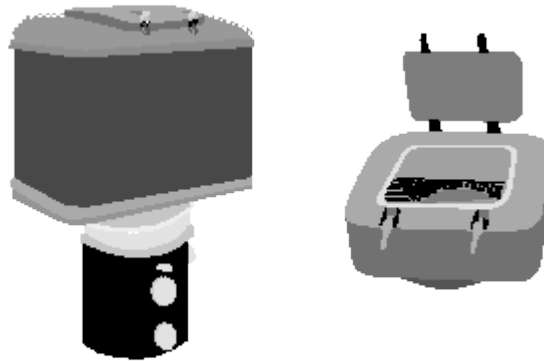

Figure 4: Monorator.

---

The practical experiences with the new design were however baffling: the car not only operated satisfactory with regular air-dry fuel, but also with fresh wood the motor ran reliably and with acceptable power.

It is rather odd that the inventor himself in the early stage was not entirely aware of what he indeed had created. Even several years ago, he got a very good offer but dared not even sell the manufacturing right, since he yet not had the faintest idea about in where the secret lied.

## The principle of the monorator

---

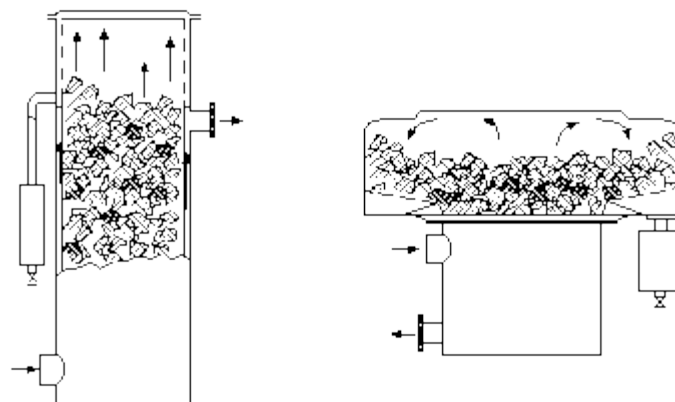

Figure 5: Gasifier, to the left a standard model, to the right with monorator container.

---

The difference between a regular container with cooling mantle, and a monorator is shown in figure 5. In a regular gasifier, the fuel container is tall and lean, surrounded by warm gas, and only equipped with an in comparison small cooling surface at the top. The bottom of the container is also heated to its full extent. In the monorator however, the fuel tank is low, made either circular, oval, or rectangular, with a bottom surface that is cooled to most of its extent, or at least has a cooled surface that is significantly larger than the cross section area of the gasifier itself. While the fuel container in the standard gasifier is heated both from the hearth as well as from the hot gases that are lead around the lower parts of the container, only parts of the fuel in the monorator receives heat, and only from the furnace, while the main portion of the fuel is protected from heating due to the shape of the fuel container and the special form of the cooled bottom, and is cooled by the proportionally large cooling surfaces in contact with the surrounding air.

Due to the form of the container and the way it is heated, the circulation of gases will be fully fixed: heating and vaporisation take place solely in the centre and in a limited volume, so that only a fraction of the fuel is dried and carbonised, whereupon vaporisation keeps itself within such limits, that an overpressure is avoided. The damp, hot gases rise upwards to the centre of the container, divert to the sides by the top of it, and then are cooled down by the cool main fuel supply and by the large cold outer walls, so that moisture is condensed and sinks down along with the gases towards the bottom, where the condense water goes through the bars and is collected in a fully cooled furrow, and then flows on to the separation vessels. The main part of the fuel compartment operates thus as a surface condenser with a very large surface. The gases, liberated from the moisture, are then sucked in towards the centre and return to the process.

Contrary to the determined circulation in the monorator, the circulation in a regular gasifier is completely chaotic. Since the walls of the fuel container is heated, practically the whole fuel storage will be warmed up simultaneously, resulting in a too drastic and sudden vaporisation, so that the container operates as a steam boiler whose pressure forces the steam out through the reaction zone, which hereby is cooled and gas quality decreases.

Because the walls of the fuel compartment is heated up, a drying process takes place along them, where the hot gases rise upwards, and thus obstruct the occurrence of the determined circulation described above. Even if the proportionally insufficient cooling surfaces condense any water, it will again be heated by the rising hot gases and from the bottom, heated by conduction, so that the major part of it once more is vaporised and an efficient separation therefore cannot be achieved. Above all, the contact surface of the fuel itself cannot work as a cooling surface, since the amount of water which is condensed here is not taken out of the system as in the monorator, but trickle back to the combustion zone and must once again be vaporised.

## Practical driving tests

When we first heard about the monorator, the collective assumption was that it was a matter of pure humbug, as it was considered unthinkable to use wood in a vehicle wood gasifier, that was dripping wet and taken directly from growing trees. The information was however confirmed from an unbiased source, and I was personally given an opportunity to drive with such fuel and perform various drastic experiments. Thus we could, during the driving tests, stop the car, open the hatch on the gasifier and toss in a huge ball of snow of 6--8 kg weight, whereupon the driving was resumed without any complications whatsoever. After a while the maneuver was repeated and a curious gasping audience came to the astounding, though somewhat incorrect conclusion that the gasifier worked on nothing but ice and snow, and the operation of it therefore was unusually cheap.

## Laboratory tests

To verify the theory put forward herein, two gasifiers of about the same capacity was undergone comparative tests at the heat power laboratory at the Institute of technology in Helsinki. One of the gasifiers was equipped with a monorator container, while the other was a regular standard gasifier without condensing mantle and with the whole fuel compartment heated by the generated gases. The device used during the test is shown in figure 6.

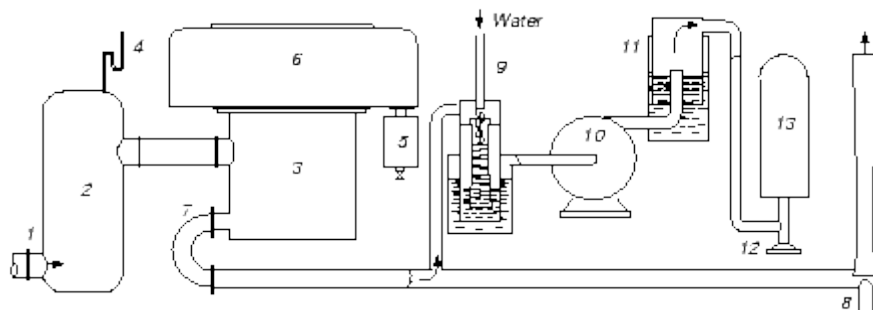

Figure 6: Diagram over the test equipment.

Through a calibrated Poncelet-nozzle 1, air is sucked into a vessel 2, from which it goes on to the gasifier 3. With the mercury barometer 4 the vacuum of the vessel 2 is measured, so that one can, at any time, determine the amount of air sucked in per time unit, and from that calculate the load of the gasifier. In the separation vessel 5, condense water is collected and removed. The gas is sucked out from the gasifier at 7 with an ejector 8 operating on compressed air, and blown out to the outside air, but apart from that and through a side pipe, using a pressured water operating ejector 9, a small amount of gas is led via a gas meter 10, and a small gasholder 11, to a Bunsen burner 12, where it combusts and deliver its heat to a Junker calorimeter 13.

The gasifier is placed out on the yard and cooled by a fan, so that the conditions correspond to practical operation; all other equipment was placed indoors in the laboratory.

Since a car in operation always is subject to both sudden and quite abrupt variations in load, an examination on a test bench would be altogether illusory if not the gasifier also in this situation is operated in a similar manner. To be able to estimate the variations in the composition of gases, it is necessary to take gas samples practically continuously. But as the tests are rather simple and easy to perform, the heat value of the gas could be determined twice a minute, which has shown to be sufficient.

To create a fully viewable image of the gasifier's operation, diagrams were drawn, where the values as measured during the test, gasifier load, and the calorific heat value of the gas, were drawn as functions of time. The effective heat value is, as well known, somewhat lower or diminished by the vaporisation heat of the water formed in the combustion. However, since the measurements shown that this value was relatively small and about the same in all the tests, it was decided to leave it out without consideration, particularly as it was only a matter of relative values, and not absolute ones.

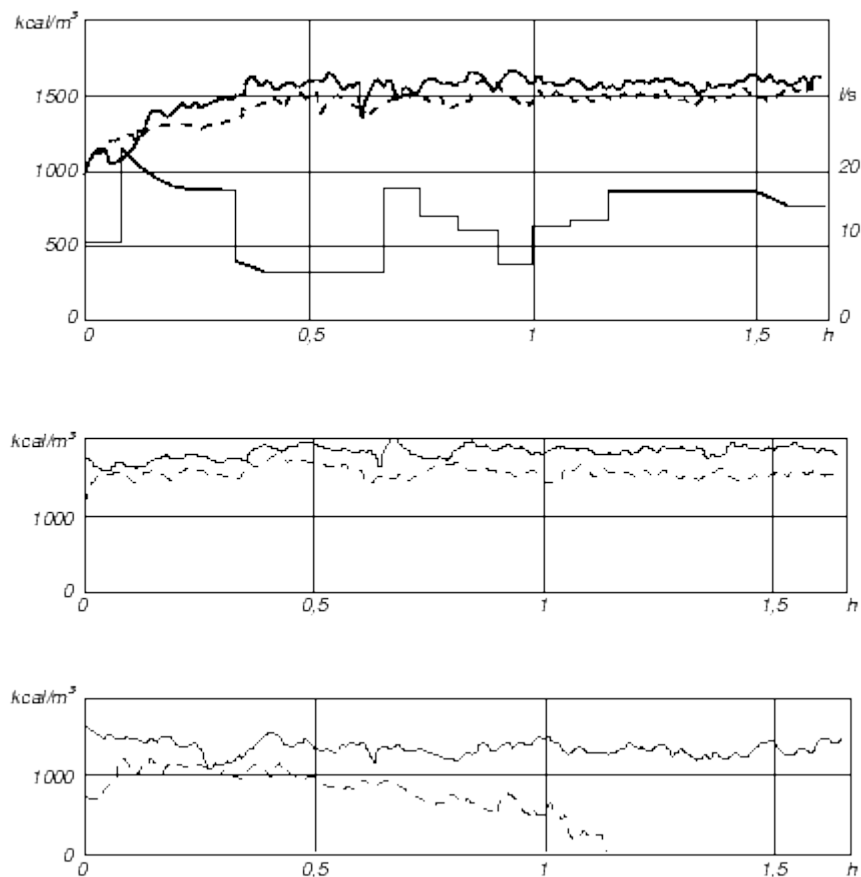

top: oven dried wood (8.6 % moisture),

middle: air dry wood (19.5 % moisture),

below: damp wood (about 47 % moisture)

-- -- -- -- standard gasifier,

----- monorator.

Figure 7: Heat value of the gas when using:

In figure 7 a number of curves has been drawn, which show how the calorific value has varied when fuel of varying moisture has been used in monorator versus a standard gasifier. For the variations in load, only a single graph has been drawn, since the load was set practically identical for all tests. Furthermore, it should be noted that the gas can be considered fully satisfying if its calorific value reaches 1150 kcal/m<sup>3</sup>.

Conclusions:

- The drier fuel, the better gas, regardless if the gasifier is a standard or monorator gasifier.
- A slightly better gas was achieved with the monorator gasifier than with the standard gasifier.
- When using very damp fuel in the standard gasifier, the gas quality dropped more and more, until the gas was completely incombustible and the flame went out in the Junker device, while the monorator still delivered a fully acceptable gas.

During the tests it was also established, that the gas being sucked out from the monorator gasifier and blown out in the open air remained transparent even when severely damp fuel was used, while the standard gasifier under similar conditions delivered a rather thick fog, suggesting that excess water in the former case was removed in advance from the gasification process, but not so in the latter case.

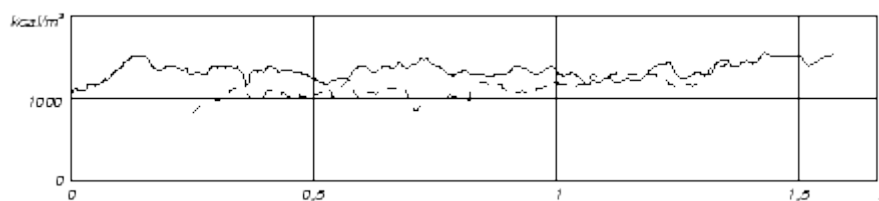

Figure 8: Test with cooled and uncooled monorator container, using wood of about 45 % moisture.

To examine the impact of the cooling of the monorator container, a number of tests were carried out with the gasifier indoors and without efficient cooling. In figure 8 we compare the results from such a test with the results from the one with a gasifier operating with a cooled fuel container. The difference is conspicuous: in spite of the fact that significantly more moist wood was used in the cooled monorator, the produced gas is much better. Not until the end of



the test when the wood supply had gotten time to dry, the heat value rises for the uncooled gasifier also. During the tests it was also observed that the ejected gas became slightly foggy when cooling was slow, and that the separated amount of distillate was much smaller than usual.

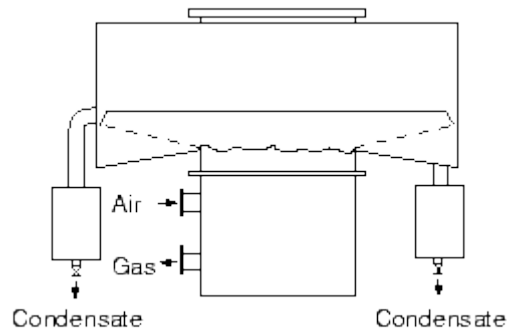
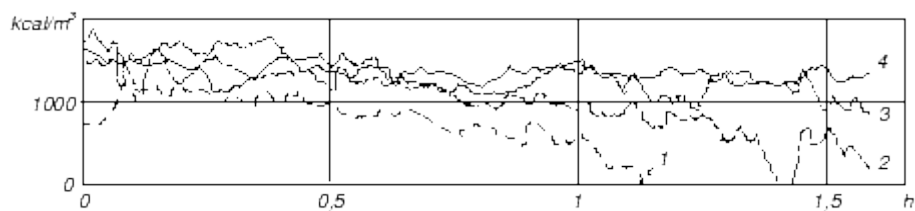

Figure 9: Test-device for examining cooling effect.

To examine the cooling effect of the main fuel supply's contact surface a furrow was attached to the base of the cooling mantle and equipped with an extra separation vessel (figure 9). From this we could see that only a third of the distillate was collected from the furrow near the mantle, while two thirds were collected by the regular separator, which suggests that only 30 % is condensed directly by the outer cooling mantle, while the majority is condensed within the fuel itself. In the end it is of course the cooling mantle which lead away the heat, while the reserve fuel works as an accumulator of the cold.



1. standard gasifier without condenser
2. standard gasifier with monorator container
3. standard gasifier with shortened container and monorator
4. pure monorator design

Figure 10: Heat value of producer gas from different gasifiers using wood of about 48 % moisture;

To further confirm that that the results achieved with the monorator depended not upon the furnace but rather upon the design of the fuel container, a number of tests were carried out with a standard gasifier, equipped with a monorator container above the regular fuel container, and also with a cut off container and monorator on top of that. The results are shown in figure [10](#). Severely moist wood was used in all tests. From the results we can see that a standard gasifier operates better with damp fuel, if it is equipped with a monorator container, but that the heated container still impairs the result, albeit to lesser extent the more this heated container is shortened.

These results definitely kills the popular myth that it doesn't matter if the recaptured heat is used for pre-heating air or pre-heating fuel.

## Applications

The tests show, that older standard gasifiers can easily be altered so that they become suitable also for damp fuel, if only the original, pre-heated fuel container is removed and replaced with a monorator container. Since the furnace generally lasts longer than the fuel container, which is subject to the corroding acids from the wood, most existing gasifiers have gotten their fuel containers corroded already, and the switch to monorator container thus will not imply extra costs, the lesser considering the fact that these have single walls and therefore saves metal. In Finland, the Ministry of Public Provision has taken this into consideration and indeed prohibited manufacturing of double-walled gasifier fuel containers.

Also for industrial gasifiers the monorator container ought to have its importance. Here if ever the rule is that raw material preferably should be used as is, and this is made possible with the monorator. Some technical details ought to be changed; the air cooled mantle could be made water-cooled, or be sprayed on the inside with water, or water could be pumped directly into the fuel container's upper part near the sides, whereby the peripheral parts of the fuel container will work as an excellent spray condenser, which stimulates the earlier mentioned circulation and separation process. Engineer U Blomquist has suggested yet an improvement, namely to let the fuel be surrounded by a heat conducting coarse filling, which probably will further improve the monorator effect. Experiments with this are planned but yet not carried out.