

UC-NRLF



B 3 112 975

JUN 7 1909

Mining dept.

LIBRARY
OF THE
UNIVERSITY OF CALIFORNIA.

Class

HEAT ENERGY AND FUELS

PYROMETRY, COMBUSTION, ANALYSIS OF
FUELS AND MANUFACTURE OF
CHARCOAL, COKE AND
FUEL GASES

BY
HANN S V. JÜPTNER
PROFESSOR, IMPERIAL AND ROYAL TECHNICAL INSTITUTE,
VIENNA

TRANSLATED BY
OSKAR NAGEL, PH.D.



NEW YORK
McGRAW PUBLISHING COMPANY
239 WEST 39TH STREET
1908

TP 318
J8

MINING DEPT.

Mining Budget
mcc

COPYRIGHT, 1908,
BY THE
MCGRAW PUBLISHING COMPANY
NEW YORK

Stanhope Press
F. H. GILSON COMPANY
BOSTON, U.S.A.

TRANSLATOR'S PREFACE

PROFESSOR HANNS VON JÜPTNER has divided the study of chemical engineering into two groups, namely: energy and matter; and beginning with a general discussion of the various forms of energy, has written four volumes covering the subject both theoretically and practically.

The present volume deals with heat energy and fuels, and contains a large amount of carefully tabulated data in convenient form for use. A great deal of this data is new and will be welcomed by chemists, metallurgists and engineers.

Although the book is intended for use in universities and engineering schools it is of equal value to practising engineers, since it gives not only the fundamental principles, but also the latest experimental data and practice.

Among the topics of greatest practical interest are: Measurement of high temperatures and late data on the melting points of various substances; discussion of incomplete combustion, combustion temperatures and combustion at constant volume and constant pressure, and an immense amount of data on solid, liquid and gaseous fuels and their production. The chapters on the gasification of fuels, which contain the results of the author's own experiments as well as those of Strache and Jahoda, are of especial value.

The book has been extremely well received in Europe, where it is widely used both in schools and in practice as a text-book and handbook.

THE TRANSLATOR.

NEW YORK, *November*, 1908.

CONTENTS

INTRODUCTION.

CHAPTER	PAGE
I. GENERAL REMARKS.....	1
II. FORMS OF ENERGY.....	11

VOLUME I. HEAT ENERGY AND FUELS.

Part I. Heat Measurement, Combustion and Fuels.

I. THE MEASUREMENT OF HIGH TEMPERATURES (PYROMETRY)..	37
II. PYROMETRY (Continued).....	53
III. PYROMETRY (Conclusion). OPTICAL METHODS OF MEASURING TEMPERATURES.....	68
IV. COMBUSTION HEAT AND ITS DETERMINATION.....	91
V. DIRECT METHODS FOR DETERMINING THE COMBUSTION HEAT	110
VI. INCOMPLETE COMBUSTION.....	117
VII. COMBUSTION TEMPERATURE.....	127
VIII. FUELS (In General).....	141
IX. WOOD.....	145
X. FOSSIL SOLID FUELS (In General).....	155
XI. PEAT.....	166
XII. BROWN COAL (Lignite).....	173
XIII. BITUMINOUS AND ANTHRACITE COALS.....	178
XIV. ARTIFICIAL SOLID FUELS.....	188
XV. CHARCOAL.....	191
XVI. PEAT-COAL, COKE AND BRIQUETTES.....	214
XVII. COKING APPARATUS.....	230
XVIII. LIQUID FUELS.....	241
XIX. GASEOUS FUELS.....	243
XX. PRODUCER GAS.....	246
XXI. WATER GAS.....	268
XXII. DOWSON GAS, BLAST FURNACE GAS AND REGENERATED COM- BUSTION GASES.....	287
XXIII. APPARATUS FOR THE PRODUCTION OF FUEL GASES.....	292
INDEX.....	303



HEAT ENERGY AND FUELS

INTRODUCTION.

CHAPTER I.

GENERAL REMARKS.

IF we consider the immense strides that technical science has made in the second half of the nineteenth century; if we observe how prosperity is increasing, especially in the countries prominent in engineering; and how, as a natural sequence, the standing and influence of engineers are constantly growing in these countries, we are forced to ask by what means all this has come to pass — in other words, to what circumstances are we indebted for this remarkable progress?

A close study of the development of technical science shows its close connection with the natural development of mankind.

At first, man had no other resource in his struggle with wild animals and natural forces than himself, that is, the organs given him by nature. Necessity taught him how to protect himself from cold by means of clothes, to seek protection from exposure to the weather, and led him to build dwellings. Nature gave him a cave for his first home, but he soon learned to construct artificial shelters.

In his struggles with wild animals he tried to increase his efficiency. For this purpose he first tried to lengthen his reach with a stick. Then he found that a thrown stone was able to act far beyond the immediate range of his arm.

He soon found that there were expedients for using the strength of his muscles to greater advantage, and he began to devise primitive *tools* in the widest sense of the word. His problem now was to select the material most adapted to his purposes from the mineral, vegetable and animal kingdoms; thus his knowledge of nature was considerably increased. As

the material suitable for his tools and implements could not always be found near at hand, man had to get it by barter, and we have the beginning of commerce and traffic.

It was a great advance in the progress of civilization when man learned to use fire; this discovery is of special interest to us as chemical industry depends on it. In close connection are the manufacture of burned clay-vessels (the beginning of ceramics) and the production of metals, both of which are of the greatest importance in the development of civilization, as they furnish materials that are especially suited for the manufacture of implements and arms of various kinds. Herewith are connected other improvements, such as the preparation of food by boiling, broiling, roasting and baking, the preparation of alcoholic beverages, the use of fermentation in baking bread, dyeing, tanning, etc.

At first man lived alone or banded in small families. With increasing civilization, especially after the beginning of agriculture and cattle-breeding, which enabled a number of people to live together by insuring the necessities of life, clans were formed by the union of families, and therefrom, gradually, the nations. Thus division of labor was made possible; the individual members of such families or clans were enabled to devote their time to the solution of certain tasks, according to their individual skill and inclination. Gradual evolution along these lines, in the course of thousands of years, resulted in the differentiation of skilled labor into distinct trades and professions, and on this foundation modern engineering and the modern industrial system developed.

In the Middle Ages the skilled artisans were working by rule of thumb, and frequently kept their methods of working secret. At that time there was no engineering science in existence in the modern sense of this word. This is but natural, since the process of reasoning was hampered by insufficient and conflicting data; and was, moreover, entirely different from our modern way of thinking, the base of which is natural science. This interfered with the progress of the trades and the development of progressive methods. The period of Renaissance only brought a change by guiding us back to the observation of nature.

This change, naturally, could take place only slowly and gradually, as there is no more difficult task for a man, not

accustomed to it from his youth, than to observe and think accurately; on the other hand, the scientists formed at that time an entirely separate class, just as did the trades and professions, and a long time was required before the gap between the two was bridged over, so that science and the trades could work together.

At first the sciences had to be developed, before being utilized in the trades; but soon — at least in some directions — mutual relations presented themselves, which decreased the gap, at the same time advancing both science and the trades. Thus the invention of the printing press made it possible to communicate one's thought or word easily to all the world, while the invention of the steamboat and railroad brought people in different countries directly together. Commerce became a world power and opened new markets. Competition started and with it came the necessity of making improvements.

In this way in the course of the nineteenth century modern engineering and the technical sciences originated, which now represent one of the most influential factors in modern civilization. But this enormous progress was directly based upon the correct practical application of the natural sciences.

Whereas formerly science was the foundation on which modern engineering developed, the reverse is now often the case. Every new scientific invention is still carefully followed up by the engineer and utilized for practical purposes, even more than ever before. But it often now happens that the engineer promotes science by making a scientific research in order to solve a technical problem.

This indicates what must be demanded now of a good engineer.

He must have a thorough scientific education and must be able to work scientifically in unexplored fields; he must gain practical experience, which necessitates highly developed powers of observation, and he must have the faculty of utilizing the results of science in practice. For this purpose he must be able to think logically, scientifically and technically, for these two requirements are by no means identical.

We have seen above how the trades were gradually transformed to modern industries. Like all great changes, this transformation involved serious complications; the conflict

between capital and labor originated capitalism and socialism. Between capital, that makes the creation of large industries possible, and labor, which first of all represents the producing power in the industries, stands the engineer, the mental leader. His is the task not only to keep up order and discipline in the enterprise, but also to act as mediator between those two opposite parties. This is not easy, nor pleasant, but it is a very important duty. Its fulfillment requires energy toward both sides, and sometimes even apparent harshness; but also a good heart and the earnest desire to find out the causes that are at the bottom of the endeavors on both sides.

Every worker, including the engineer, who works with his intellect, is right in asking for reasonable wages, and it is perfectly right and proper that the capitalist, who lends his money to the enterprise, should expect a profit out of it. This is the main cause of the conflict. The industrial enterprise as such must also earn something. It is necessary to put aside capital for protection against unforeseen events and against menacing competition, for making enlargements, etc. Every industry must, therefore, endeavor to make a profit. If the management of an enterprise is to remain in the hands of the engineer he has, therefore, to be familiar with commercial questions and economic problems.

Like all others the chemical industry needs buildings, apparatus, machines, and means of transportation, and the chemical engineer should know something about these mechanical appliances, not only in the interest of the industry, but also to insure him his position, as otherwise the business management will be given into the hands of a business man, and the technical management into the hands of other (non-chemical) engineers. This will be especially the case in places where labor is scarce and wages high, as it then becomes necessary to reduce the operating expenses by the installation of mechanical appliances.

Attention has to be paid also to the welfare of the working-man by the provision of baths, hospitals, schools, etc., which also requires special knowledge.

Finally the engineer must have a very important faculty, that is, to keep cool in danger. This faculty has its own commercial value, since on it human lives often depend. Related therewith is courage, which in moments of danger enables a

man to be cautious and quick, to consider all possibilities, and to act for the greatest good.

Much is, therefore, expected of an engineer, and the question is, how shall the chemical engineer acquire all these qualities and this knowledge?

Coolness and courage are traits of character that each must acquire for himself; hence we cannot consider them here. Nor can practical experience be taught in a school, by a teacher or text-book, since practical experience is not the knowledge of such facts as are stated in technical text-books, but rather the faculty of making proper use of such facts in practice. This faculty is best acquired in practice if the eyes are kept open. Instruction, however, can help a man to educate himself in correct technical thinking, as we will proceed to show.

It is the task of the school to give to its students a thorough scientific education, *i.e.*, to give them, as far as possible, a thorough theoretical foundation. The school must encourage original research and independent scientific reasoning; it must increase the powers of observation and judgment, and must show by concrete examples how scientific results are used in practice.

But this is not so easy a task as appears at first sight. First of all the data available for lectures on chemical engineering are so limited that it is absolutely impossible to discuss and treat in detail all the branches of the industry. Only such branches of chemical engineering can be treated in detail as are either of great industrial importance (like fuels, combustion, the industry of heavy chemicals, iron and steel metallurgy, etc.) or those branches which seem especially adapted to develop in an engineer the faculties sketched above. Special stress is to be laid on the discussion of the theoretical basis of the various processes, and the discussion of apparatus is to be limited to the most important types. It may frequently happen that such typical examples are not taken from latest practice, but from older methods of operation, if the latter show the fundamental process with greater clearness.

While this principle also holds good for the writing of a text-book on chemical engineering, we are permitted to cover a wider field; for limitation in the selection of the various industries is not as essential as in lectures. However, even a text-book, the

object of which is first of all to supplement lectures, should not be too voluminous.

Compared to a book the personal lecture has a great advantage, in that the teacher can observe from the attentiveness of his students whether he is understood; and if not he can explain his subject more in detail. A text-book can, therefore, never entirely replace the lecture, but may be very useful in supplementing it.

However, neither lecture nor text-book alone can accomplish the same ends as university or college instruction, since the latter has two additional aids in excursions and laboratory work. The latter should not be limited to analytical work; on the contrary the student ought to be a good analyst when he starts to work in the chemical engineering laboratory. Naturally he has to do analytical work also in this period, but this should not be his principal work. In this stage synthetic work should be kept in the foreground, with solutions of problems such as may actually occur in practice; it is even advisable that the students learn to design plants and to make critical reports on designs which have been worked out.

This goes far beyond the ordinary limits of chemical engineering instruction and increases the work of the teacher; but it brings valuable results. This kind of instruction, however, is very difficult in the ordinary laboratories and necessitates the installation of special technological schools. Their erection would simultaneously amend another defect of present methods of instruction. As above mentioned, instruction as given now cannot but be encyclopedical and is very far from being a thorough technical education. This, however, can be remedied by giving the students in special schools an opportunity to acquaint themselves more in detail with a limited field of chemical engineering according to their choice — without changing the present encyclopedic instruction in the whole engineering field.

Excursions are also an important means of instruction, as the student has a chance to see actual industrial works, and to observe operations carried out on a large scale. If they are to be useful and profitable, a number of conditions should be fulfilled. The number of the participants should not be too great; if the number of the students is very large they must be divided into several parties. At first only short excursions

should be made to stimulate the faculty of observation of the students. An excursion must not be made before the processes used in the works to be visited have been discussed in the lectures. Interest in excursions and resorption of the things observed are increased by exercises in designing, and by working out projects, as we have already mentioned. It would also be advantageous if a professor of mechanical engineering would participate in these visits. Such excursions should be aided and facilitated by the government, railroads and manufacturers. It hardly requires mentioning that a well arranged museum or collection of things of technical interest is also of great assistance in instruction.

If we now turn to our subject proper — chemical technology — we find it difficult to define exactly the word “technology.”

The name of our science, literally translated, means “discipline of the arts” (τέχνη, λόγος). So we might conclude to define as technology the mechanics of all possible arts, from all the fine arts to the handicrafts. This, however, is not the case, as neither the fine arts and handicrafts nor agriculture and mining belong to the sphere of technology.

On the other hand, in various trades, which are not included in engineering science, the same appliances and methods are used as in engineering.

The problem becomes even more complicated if we keep in mind that in technical processes not only substances are transformed but also energies so as to assume a more useful and more convenient form.

We could, therefore, define technology as the science of the methods by which materials and forms of energy as we find them are transformed so as to become more useful and valuable.

To what extent the value of a substance is increased by the work of the engineer is shown by the following example, taken from a paper of the English ironmaster, Lówthian Bell:

Scale of Iron.	Price per Kg.	Scale of Iron.	Price per Kg.
Pig iron.....	0.01	Needles from same.....	1.3
Rail-steel.....	0.014	Fine wire.....	1.4
Gas-pipes.....	0.02	Fine needles from same.	1.68
Bessemer steel.....	0.02-0.025	Chronometer springs....	3.00
Bessemer steel wire.....	0.3	Finest watch-springs....	2000.00

The transformation of substances and energies always requires a certain amount of work and always involves the practical loss of a fraction of the substance or energy.

To carry out the desired transformation, it is necessary to install a plant with buildings and proper appliances, such as machines, furnaces, etc. The running (operating) expenses are calculated as follows:

- (a) First cost of plant (to be depreciated).
- (b) The operating expenses proper (wages, cost of raw materials, transportation, taxes, etc.).
- (c) Reserves for protection against all emergencies.

On the other hand, the unavoidable loss of material and energy in every process means a loss of capital and an increase of the operating expenses.

For effecting the greatest possible economy all these expenses and losses have to be reduced to a minimum.

The reduction of the first cost and operating expenses depends, first of all, on the methods used; and, generally speaking, the method of operation will be the more economical

1. The lower the first cost (capital invested).
2. The cheaper the labor and the raw material used.
3. The quicker the working (which means careful planning).
4. The more convenient the location (with respect to labor market and shipping facilities).
5. The smaller the loss of raw material and energy. In this respect a method can be made profitable in many cases by utilizing again the losses (at least partly) either by using them again in the same process or by converting them into marketable by-products.
6. The quality and the selling price of the finished product are naturally also of the greatest importance.

The object of a process can be of two different kinds:

The object may be, for instance, a change of form (disintegration, agglomeration into larger pieces, change of shape) or a mechanical separation into products of different values. In the case of energies the object may be to transform them into useful forms. This is the case in utilizing the energy of a waterfall or of the wind by means of water-wheels and wind-mills; or in the change of certain forms of energies into others, as in

electric generators. The science that treats on these subjects is mechanical engineering.

Secondly, the object may be to transform raw materials by chemical changes into substances of a different chemical composition, or to transform chemical energy into other forms of energy (mechanical energy, heat, light and electricity). All such processes are in the sphere of chemical engineering.

Both branches of technology, however, are so closely related that it is impossible to draw a sharp line between the two. The manufacture of paper, for instance, and iron-foundry work is frequently treated in text-books of both mechanical and chemical engineering, while the purification of sulphur occurring in nature and of the native metals is often described only in chemical works, notwithstanding the fact that only mechanical and physical processes are involved.

The chemical engineer has to use frequently, besides chemical, also mechanical means, and in many cases he has to be well informed as to water-wheels, steam-engines, blowers, pumps, etc. Mechanical and chemical changes are often so closely combined (as in annealing sheet metals, welding of iron, hardening of steel, etc.), that a correct idea of the respective processes can only be formed from a chemical-mechanical point of view.

According to these explanations chemical technology can be divided into two main groups:

1. Chemical technology of the energies.
2. Chemical technology of materials.

This book will treat of the first.

In the chemical technology of materials use must be made of energy for forming the desired products, while in the chemical technology of energies materials must be employed as carriers of chemical energy. No strict division can therefore be made between these groups, but it presents many advantages for instruction.

We therefore comprise under "chemical technology of the energies" the science of the change of chemical into other forms of energy and will consider the transformation of chemical energy into

(a) Heat (by combustion, generated or consumed by other chemical processes; firing and refrigeration).

(b) Mechanical energy (explosives and internal combustion engines).

(c) Radiant energy (mainly light, *i.e.*, chemical illumination; transformation into heat-rays is considered under *a*).

(d) Electricity (galvanic cells and storage batteries).

Especially in the case of production of heat from fuel, and in the case of explosives and illuminants, it is hardly possible to separate chemical technology of energies from the materials that furnish the chemical energy to be transformed, so that we will find it necessary to consider also the technology of these materials.

CHAPTER II.

FORMS OF ENERGY.

ENERGY is the power to do work, if we call work a change of state in general.

The performance of all our industrial operations requires a considerable amount of energy, for instance, mechanical energy in the working of metals, disintegrating of phosphates, cements, and other raw materials for conveying and transporting materials; heat energy for melting metals and burning of lime, cement and ceramic products; electric energy for illuminating, refining of copper, production of aluminum and chlorine; light energy for illuminating and photography; chemical energy in the production of chemical compounds, as chlorate of potash, explosives, etc.

Energy cannot be made from nothing, but has to be procured from the natural reservoirs of energy in which it is accumulated. We are, however, enabled to draw from the accumulated energies of nature, and by means of certain machines to transform them into other forms of energy, but without increasing the total amount. This is, for instance, done in steam engines, electric generators and batteries, etc.

Of the natural reservoirs of energy, the following are of industrial importance:

1. Live motors (man, horse, etc.).
2. Falling water (waterfalls, creeks, rivers).
3. Moving air (wind motors and sailing vessels).
4. Substances in which chemical energy is stored. The most important of these are the fuels.

All these available sources of energy are actually only intermediate reservoirs, their energy having been obtained from the sun in a more or less direct way. The sun is, therefore, the original source of all energy, of all heat, of all electric energy and of all chemical phenomena on the surface of the earth.

The sun transmits energy to the waterfalls by heating and evaporating sea water; transmits energy to all plants by decomposing the carbon dioxide of the air by means of its rays, transforming the plants in the ground into fossil coal.

It is evident that by this transmission a large amount of solar energy is lost. We have to add, for instance, to the water for evaporation the total latent evaporating heat, which is again liberated by the condensation to liquid water and a large part of the water condensed in the mountains cannot be utilized, partly on account of practical reasons, partly on account of its seeping into the ground, and partly on account of the evaporation on its downward way; therefore the experiments for directly utilizing the radiant energy of the sun deserve our most earnest consideration. Precisely speaking, however, all these losses are only losses to the industrial world and not to the earth, as, for instance, by the condensation of water-vapor, the air layers, in which this phenomenon takes place, are warmed up.

The radiant energy of the sun is, therefore, the only source from which the energy-content of our earth can be increased, and the radiation of the earth is the only source of energy-losses.

Before going into the details of the chemical technology of energies it might be well to say a few words about the different forms of energy.

All possible changes occurring in a system can be referred to three fundamental quantities: The mass (M), the space, which can be conceived as the cube of length or distance (L^3), and the time (T). All these changes can be reduced to changes of energies and we can therefore measure all forms of energy by using as units mass, distance and time.

If we allow a system to go through certain changes without adding or deducting energy, so that it returns again to the first state, then the system contains again the same form and the same quantity of energy as in the beginning. Energy cannot be lost or generated, but only transformed into other forms.

The mathematical expressions for all forms of energy can be divided into two factors, the capacity factor and the intensity factor. The former is more or less unchangeable, while on the

latter depends the equilibrium. Equilibrium between two quantities of energy is only attained when the intensities are equal. If we indicate the energy, intensity factor and capacity factor with E , l and c , respectively, we have

$$E = lc,$$

and therefore

$$dE = ldc + cdi;$$

if c is constant we have

$$\frac{dE}{di} = c;$$

if i is constant we have

$$\frac{dE}{dc} = l.$$

This defines exactly the nature of these energy factors.

The following are the known forms of energy:

1. Mechanical energy.
2. Heat.
3. Electric and magnetic energy.
4. Chemical energy.
5. Radiant energy.

1. Mechanical energy occurs in the following forms:

- (a) Kinetic or actual energy.
- (b) Energy of space, which can be

- (1) Energy of distance.
- (2) Energy of surface.
- (3) Energy of volume.

(a) The mathematical expression for kinetic energy is

$$E = \frac{1}{2} mv^2.$$

According to the way by which this expression is split into factors we get as capacity factor either m , which quantity is absolutely unchangeable, or mv , which is only relatively unchangeable, while as factor of intensity we obtain half the square of velocity $\left(\frac{v^2}{2}\right)$ or the velocity itself (v).

The unit of kinetic energy is the Erg (E), which is the energy contained in the mass of a gram, when moving with a

velocity of 1 centimeter per second. The dimension of the kinetic energy (expressed by M , L and T), is

$$[E_k] = \left[M \frac{L^2}{T^2} \right] = [ML^2T^{-2}].$$

The energy of space occurs in three different forms in which the capacity factor is represented by distance, surface and volume respectively. We have

Form of energy.	Capacity.	Intensity.
Energy of distance	= distance \times	force
Energy of surface	= surface (area) \times	tension
Energy of volume	= volume \times	pressure.

The energy of distance acts between two points in the direction of their connecting line. If we indicate the length (distance) with l and the force with f , we have

$$E = lf, \text{ and therefore the force}$$

$$f = \frac{dE}{dl}$$

is equal to the ratio of change of energy to change of distance (length). If the energy of distance is transformed exclusively into kinetic energy (as in the ordinary mechanical and astronomical problems) this equation expresses the acceleration, a , and then corresponds to the ordinary definition of force.

The energy of surface is active on the surface of liquids and solids. Its intensity of factor, the tension, is identical with the constant of capillarity.

The energy of volume appears in gases. Its factors are volume and pressure.

We have, therefore, the following expressions for the dimensions of the energies of space and its factors:

Capacity.	Intensity.	Energy.
distance (L)	force = $[EL^{-1}]$	E
surface (L^2)	tension = $[EL^{-2}]$	E
volume (L^3)	pressure = $[EL^{-3}]$	E

We know of two kinds of energy of distance, one of which (called gravity) acts between two material points so that the

energy increases with the distance and reaches a minimum when the points are in direct contact. It is governed by Newton's law of gravitation. If we indicate the energy of distance with E_d , the two masses acting upon each other with m and m_2 , their distance with r , we can express this law by the equation

$$E_d = c_1 - j_2 \frac{m_1 m_2}{r},$$

in which c_1 and j_2 are constants. If $r = \infty$ and $E_d = c_1$, it reaches a maximum. The differential of this equation gives us the ordinary form of this law:

$$\frac{dE}{dr} = f = j_2 \frac{m_1 m_2}{r^2}.$$

The quantity c_1 is unknown; the second constant k^2 is, expressed in the centimeter-gram-second system,

$$j_2 = 6.6 \times 10^{-8}.$$

On the surface of the earth the force of gravity can be considered constant for moderate altitudes, and the energy of distance is directly proportionate to the altitude.

The second kind of distance energy occurs for instance in electrically charged balls, and is distinguished from the former by reaching its maximum value at infinitely small instead of infinitely large distance between the bodies acting upon each other. For this energy we have

$$E = j_2 \frac{m_1 m_2}{r}, \text{ and for the force}$$

$$\frac{dE}{dr} = - j_2 \frac{m_1 m_2}{r^2}.$$

This force has therefore the same formula as in the first case, but is negative. While the gravity is an attracting force, this force is repulsive.

We have seen above that two masses acting upon each other, under the influence of gravity, tend to approach each other; whereby the distance energy is decreased, being partly transformed into kinetic energy.

The decrease of distance energy, corresponding to a decrease in l of dl is

$$dE_d = j_2 \frac{m_1 m_2}{r^2} dr.$$

If we suppose

$m_1 = M$ mass of the earth and $m_2 = m$ mass of a falling body, $r = R$ the radius of the earth and $dr = dh$ is an increment of the fall-distance, corresponding to an infinitely small change of distance energy, we have

$$dE_d = j_2 \frac{M}{R^2} m dh, \text{ an expression wherein } j_2 \frac{Mm}{R^2} = f \text{ (gravity).}$$

Thence we can write

$$dE_d = f dh.$$

As the lost distance energy is completely transformed into kinetic energy of the equation $dE_k = mv dv$ we can make both expressions equal:

$$f dh = mv dv.$$

By integration between o and h and o and v respectively we obtain

$$f \int_0^h dh = m \int_0^v v dv \text{ or}$$

$fh = \frac{mv^2}{2}$, as the fundamental law for the mutual transformation of kinetic and distance energy.

If we put into $f dh = mv dv$ for the acceleration the value $v = \frac{dh}{dt}$, we get Galileo's law of fall:

$$f dt = m dv, \text{ or}$$

$$\frac{dv}{dt} = \frac{f}{m}.$$

Equilibrium between kinetic energy and distance energy can only exist if the two masses, acting upon each other, are moving around their common center of gravity.

Analogous to the two kinds of distance energy we can imagine two kinds of surface energy; however, we know only one of them, *i.e.*, the one that tends to decrease the surface.

The cause of this is called tension (γ). σ being the surface, we have

$$\frac{dE}{d\sigma} = \gamma,$$

which quantity is identical with the capillary constant. The surface tension is, down to very thin layers, independent of the thickness of same, is proportional to the surface, and is dependent on the temperature and on the nature of the substances separated by the surface.

A peculiar property of the surface energy is that changes in its value are accompanied by changes of heat energy. If, for instance, a soap bubble is increased by blowing, the surface energy increases more than would correspond to the mechanical energy used in blowing, the heat content decreases by a corresponding amount, or, if the temperature is kept constant, the requisite heat has to be added from the outside. During the contraction of the bubble the entire amount of the disappearing surface energy cannot be transformed into mechanical energy, since as much heat energy is again produced as was transformed into surface energy during the first process.

Phenomena of equilibrium between surface energy and energy of gravitation occur in the rise of liquids in narrow tubes. g being the weight of the raised liquid and dh the elevation to which corresponds the infinitely small decrease of the surface, we have for the equilibrium

$$\gamma d\sigma = g dh.$$

As the decrease of the surface ($d\sigma$) must equal the product of the tangent-line (u) and the change of height (dh),

$$d\sigma = u dh,$$

we have

$$\gamma u = g,$$

i.e., the weight lifted equals the product of surface-tension and tangent-line.

For the intensity factor of the volume-energy we have the expression

$$\frac{dE}{dv} = p.$$

Of the two possible kinds of volume-energy only that is of practical importance which decreases with increasing volume.

If a gas or vapor is given off from a solid or liquid substance at constant temperature and constant pressure, we have

$$E_v = C - p(v - v_0),$$

or, considering only the volume of the gas formed,

$$E_v = C - pv.$$

In this equation for one mol of all gases $C = RT$, which quantity is known from the gas-equation.

For an infinitely small change of volume of gases at constant pressure we have

$$dE_v = -p dv.$$

From the equation

$$pv = RT,$$

$$p = \frac{RT}{v};$$

therefore

$$-dE_v = RT \frac{dv}{v},$$

and

$$-E_v = R \int T \frac{dv}{v},$$

or, for constant temperature,

$$-E_v = RT \int \frac{dv}{v}$$

By integration between v_1 and v_2 we get

$$RT \log \frac{v_2}{v_1} = E_v' - E_v''.$$

There is little known of the relation between volume-energy, volume, and pressure, except in the case of gases.

For the equilibrium between volume and distance energy such as takes place, for instance, in a cylinder filled with gas, in



which a pressure is exerted upon the gas by a piston working without friction, we have

$$j dh = p dv.$$

The cross section of the cylinder being q ,

$$dv = q dh,$$

then

$$pq = f,$$

i.e., the force equals the product of gas-pressure and cross-sectional area.

Before mentioning the other forms of energy we want to consider a few general important considerations.

If there is no equilibrium in a system between the forms of energy present, the system is undergoing a change so that the decrease of one form of energy is greater than the increase of the other. Then energy goes over from places of higher intensity to those of lower intensity whereby it is sometimes transformed into other forms of energy; to what extent such a transformation takes place depends on the nature of the system, which — inasmuch as it effects a transformation of energy — is called a machine.

In the above supposed case of unbalanced energy the necessary change of state of the system can take place in various ways. A lifted stone, for instance, can fall vertically to the earth or can slide down an inclined plane. It will select, in fact, the way along which it attains in the same length of time the greatest possible kinetic energy. The generalization of this principle is: Of all possible transformations of energy the one will take place that will produce in a given time the largest transfer of energy from the original form to some other.

2. Heat was the first form of energy to be recognized as an independent quantity. In connection with this form of energy two important laws were formulated, which laws also hold for all the other forms of energy:

(a) *Thermodynamic law*: Heat can be transformed into mechanical work and other forms of energy and *vice versa*. This transformation takes place according to certain definite

laws. This law is based upon the fact that energy cannot be made nor destroyed, but only transformed from one form into another. Clausius has formulated this same law as follows: the energy of the universe is constant.

(b) *Thermodynamic law:* Heat cannot go of its own accord from a colder to a warmer body. Applying this law to all forms of energy we can say: If two bodies are in equilibrium with a third with respect to certain forms of energy, they are also in equilibrium with each other as regards the same forms of energy.

If we add to a body the heat dQ at the absolute temperature T , we have

$$\int \frac{dQ}{T} \begin{cases} = 0 \\ < \end{cases} \quad (= \text{for reversible, } < \text{ for non-reversible processes}).$$

The second law has, furthermore, another important meaning. In a reversible process, carried out between very narrow limits of temperature (between T and $T + dt$), the heat quantity added to the system being Q , the infinitely small part

$$dQ = Q \frac{dT}{T}$$

of this added heat can be transformed into work or other forms of energy. This is a law of special importance in the study of energy. As, according to above explanation, we have for reversible processes $\int \frac{dQ}{T} = 0$, $\frac{dQ}{T}$ must be the total differential of a quantity which — just as the energy — depends only on the state of the body, but not on the way by which this state was reached. Clausius calls this quantity “entropy,” and it is generally denoted by s , and by introducing this quantity into the second principle we get

$$dQ = T ds.$$

Like all other forms of energy the heat can be decomposed into two factors, one of intensity and the other of capacity. The former is the temperature, while the latter, according to circumstances, is represented by the entropy or heat-capacity.

The general equation of energy being

$$E = ci,$$

and the total differential

$$dE = c di + i dc$$

we have for a constant c ($dc = 0$);

$$\frac{dE}{di} = c,$$

and for constant i ($di = 0$)

$$\frac{dE}{dc} = i.$$

For the heat we have $i = T$. If we add to a substance the heat quantity dQ , so that no other form of energy is generated (without being considered) and if we determine the relation between the heat added and the increase of temperature effected thereby, we have

$$dE = c dt,$$

wherein c stands for the heat capacity of the substance.

In melting and evaporation and solidifying or condensation respectively, and also in many chemical processes taking place at constant temperature we have

$$dE = dcT$$

or analogous to the former equation

$$dE = dsT.$$

The total values of the entropy being unknown we have to transform these equations by referring them to two states marked by index 1 and 2:

$$(s_1 - s_2) dT = (c_1 - c_2) di.$$

We have, for instance, assuming equilibrium between heat and volume-energy,

$$(s_1 - s_2) dT = (v_1 - v_2) dp,$$

or,

$$\frac{s_1 - s_2}{v_1 - v_2} = \frac{dp}{dT}.$$

If we indicate the latent heat of the process referred to (chemical reaction, etc.) by l we have

$$s_1 - s_2 = \frac{l}{T},$$

and therefore

$$\frac{l}{T(v_1^* - v_2)} = \frac{dp}{dT},$$

which expression is correct for all changes of the state of aggregation and all chemical changes of state, that are connected with a change of volume. We can transform it into

$$\frac{l dT}{T} = (v_1 - v_2) dp \text{ (Clapeyron's equation).}$$

4. As coefficient of capacity of chemical energy the gram-atom of the elements or the gram-molecule is generally used, while as coefficient of intensity the "chemical potential" or simply "potential" is used (J. Willard Gibbs). For the latter quantity we have, according to the general energy-equation,

$$i = \frac{dE}{dc}.$$

The individual values of the quantities of chemical intensity being unknown, we can only consider their sum as appearing in equations of chemical reactions. If, for instance, E_1 and E_2 represent the total chemical energy-content of a system in the beginning and end state respectively, q being the energy generated (liberated) in going from 1 to 2, we have

$$E_1 = E_2 + q.$$

If we divide now both sides of the equation by the capacity c of the system (c remaining constant in the processes under consideration) we get

$$\frac{E_1}{c} = \frac{E_2}{c} + \frac{q}{c},$$

or,

$$i_1 = i_2 + \frac{q}{c}.$$

If we divide each of the equations (2) with the corresponding capacity value, we get the intensity-equation

$$\left. \begin{aligned} i_1' &= i_2' + \frac{q'}{c'}, \\ i_1'' &= i_2'' + \frac{q''}{c''}, \\ \dots\dots\dots \\ \dots\dots\dots \end{aligned} \right\} \quad (5)$$

and therefore for the total reaction

$$i_1' + i_1'' + \dots = i_2' + i_2'' + \dots \quad \sum \frac{q}{c}. \quad (6)$$

It is necessary that for the equilibrium $i_1' + i_1'' + \dots = i_2' + i_2'' + \dots$ and this is only possible if $\sum \frac{q}{c} = 0$, i.e. if $\sum q = 0$.

Now we can arrange the intensities corresponding to the original and final systems so that they correspond to the different compounds appearing in the reaction-equation; if we also sum up the quotients $\frac{q}{c}$ and distinguish by index the sums of intensities corresponding to every substance, we get the expression

$$\sum_1' i + \sum_1'' i + \dots = \sum_2' i + \sum_2'' i + \dots + \sum \frac{q}{c}.$$

For equilibrium
$$\sum \frac{q}{c} = 0.$$

It could be thought from the above explanation that the energy of reaction of a reaction represents directly the change of the chemical energy of the system, when passing from the original to the final state. This conclusion, however, would be incorrect, since not only the chemical but also all the other forms of energy contained in the system are undergoing a change during the transformation. But we can go a little further in the case of chemical equilibrium, since in this case the intensities of the original and final system must have become equal, and since the capacity of the system must

remain constant during the transformation, the amounts of the various forms of energy also must be equal to each other. In the case of the equilibrium, therefore, the heat-force of a reaction measures the distance of the non-chemical energy values before and after the reaction.

For ascertaining the changes of chemical energy of a system when passing from one state to another, we can start from the energy of reaction accompanying this change of state, considering also the changes that the other forms of energy are undergoing. As such we find mainly the heat and the energy of volume, which will be better understood by the following example.

The reaction

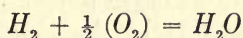

takes place with generation of heat. The quantity of this energy of reaction is calculated by means of Kirchoff's law as follows:

$$Q_T = 58,294.6 + 3.25 T - 0.002 T^2.$$

If the combustion is effected at constant pressure and at constant temperature, the difference of the heat-content in the original and final state is calculated as follows:

Heat content	= spec. heat \times abs. temperature
Original system	= $1.5 (6.5 + 0.0006 T) T$
Final system	= $(6.5 + 0.0029 T) T$
Decrease of heat content	= $3.257 T - 0.002 T^2$

If we deduct this decrease of the heat content (ΔW) from the energy of reaction, we get

$$Q_T - \Delta W = 58,294.6 \text{ cal.}$$

We have to consider now the change of the volume-energy. The combustion taking place at constant pressure, the volume is decreased in the ratio 1.5 to 1, *i.e.*, 1 mol steam is formed from 1.5 mols hydrogen and oxygen. The volume-energy of the system is hereby increased by $0.5 RT$. This increase of the volume-energy, however, takes place under the influence of the outside pressure, is therefore representing the addition (supply) of foreign energy, and therefore has not to be considered here.

Hence we have, for the decrease of the chemical energy of

the system in the complete transformation from original to the final state,

$$\begin{aligned}\Delta E &= E_1 - E_{11} \\ &= q_T - (c_1 - c_{11}) T \\ &= q_0\end{aligned}$$

We get the same result if the reaction takes place at constant volume. In this case both the energy of reaction and the decrease of the heat-content become less by $\frac{1}{2} RT$, since c_v is used instead of c_p .

The change of the chemical energy is therefore independent of the temperature and equal to the energy of reaction at absolute zero.

TABLE I.
ENERGY OF VARIOUS REACTIONS.

g.-molecules.	g.-cal.
$H_2 + \frac{1}{2} O_2 \rightarrow H_2O$	58294.6
$CO + \frac{1}{2} O_2 \rightarrow CO_2$	68182.4
$C + \frac{1}{2} O_2 \rightarrow CO$	28674.5
$C + O_2 \rightarrow CO_2$	96856.9
$N_2 + O_2 \rightarrow 2 NO$	43000.0
$2 CO \rightarrow CO_2 + C$	39507.9
$CO_2 + H_2 \rightarrow CO + H_2O$	- 9887.8
$C + H_2O \rightarrow CO + H_2$	-29620.1
$C + 2 H_2O \rightarrow CO_2 + 2 H_2$	-19732.3

As the direction of chemical reactions is not independent of the temperature, the chemical changes of state do not necessarily depend upon the chemical energy alone, but also upon other forms of energy. When considering a measure of chemical affinity the chemical energy alone is not sufficient, and we have to use, therefore, the change of the free energy of the system, in which the quantity q_0 appears as independent of the temperature (chemical energy).

We have seen above that chemical equilibrium can only take place if the intensity of the chemical energy before the change equals the intensity after the change. Otherwise such a change of state should take place that the intensity of this energy in the system decreases. If, notwithstanding, this transformation does not occur, the reason for this can only be looked for in the compensating effect of other forms of energy. This is of the

greatest importance, as is shown by Ostwald in the following explanation:

“In chemical energy the possibility of compensating differences of intensity is apparently very general, as can be seen from the fact, that in many cases it can be preserved without loss, practically speaking, for an indefinite length of time. The possibility of using chemical energy (*i.e.*, of transforming it into other forms) is necessarily connected with the presence of differences of chemical intensities, which can be kept up (*i.e.*, compensated) as long as desired.

“The forms of compensating energy can only in rare cases be observed. This is the reason why we know so little about the presence of a function of chemical intensity. We see that in spite of the possibility of transformation of the chemical energy into other forms, for instance, in a mixture of oxygen and hydrogen, no such transformation takes place as long as the temperature remains below a certain point. In such cases we speak of a ‘passive resistance.’ We can explain these phenomena by supposing that a compensation of the differences of chemical intensity, by other forms of energy, actually takes place, and that between the stage of oxyhydrogen-gas and of water at low temperatures intermediate stages are contained, which for the transformation (the other energy-quantities remaining constant) would at first effect an increase of the intensity factor; afterwards a very considerable decrease of the same, corresponding to the state of water, would take place. Such states are called metastable.”

3. *Electric Energy.* The magnitude of intensity of electric energy is called electromotive force, or potential difference. While, however, the intensity of heat, the temperature, is counted from an absolute zero point, being therefore always positive, no such point has been found for electric potential. It is therefore necessary to use an arbitrary zero-point whereby positive and negative potential-values are obtained.

The quantity of electricity is used as a factor of capacity. If we denote the same with E_e , the potential with π and the electrical energy with E_e , we have

$$E = \frac{E_e}{\pi},$$

or,

$$E_e = E\pi.$$

For the quantities of electricity the law of conservation can be expressed as follows: The total quantity of electricity is constant, and equal quantities of positive and negative electric energy are always present.

If two quantities of electricity, $+E$ and $-E$, concentrated in mathematical points at a distance r from each other, act upon each other, the potential difference being π , they exert upon each other a force f , which is given by the equation

$$f = -k \frac{E_1 E_2}{r^2}.$$

K depends on the nature of the medium between the two electric quantities, and is called its dielectric constant. If we call the distance traversed by the two electric quantities under the influence of this force dr , we have for the electric energy

$$\begin{aligned} dE &= -k \frac{E_1 E_2}{r^2} dr \\ &= k E_1 E_2 d\left(\frac{1}{r}\right), \end{aligned}$$

and therefore for a change of the distance from r' to r ,

$$E_r - E_{r'} = k E_1 E_2 \left(\frac{1}{r} - \frac{1}{r'} \right).$$

If we make $r' = \infty$, we have

$$E_r - E_\infty = \frac{k E_1 E_2}{r},$$

or

$$E = E_\infty + \frac{k E_1 E_2}{r}.$$

If E_1 and E_2 are both positive or both negative, we see that $\frac{K E_1 E_2}{r}$ is positive, *i.e.*, the electric energy increases with the decreasing distance, or: the two electric quantities of like sign repel each other. If, however, E_1 is positive and E_2 negative, or *vice versa*, $\frac{K E_1 E_2}{r}$ becomes negative; electric quantities of unlike signs attract each other.

If we have two infinitely large quantities of electricity of opposite sign stored in reservoirs having a potential difference π , and we connect these two electricity reservoirs by means of a conductor, electric energy will flow from both into the conductor in the same way that heat-energy passes to a cold body. Thereby the two electric quantities neutralize each other in the conductor, the electric energy being transformed into heat. This shows how the electric current is produced.

If the two quantities of electricity are not infinitely large the generation of a uniform electric current (*i.e.* the preservation of the same potential-difference between two cross sections of the conductor) will only be possible if the electric energy consumed in the conductor in the time-unit is constantly replaced at the source of the electric current. If we refer this process to the time-unit, calling the ratio of quantity of electricity to time $\frac{e}{t} = i$, intensity of current, this intensity of current must be proportional to the potential difference π and furthermore be dependent on a coefficient, the quantity of which is determined by the quality of the conductor. This coefficient is the conductance l ; its reciprocal value $r = \frac{1}{l}$ is called the resistance of the conductor.

We thereby arrive at Ohm's law:

$$\begin{aligned} i &= l \pi \\ &= \frac{\pi}{r} . \end{aligned}$$

We have seen above that in the conductor free electricity is neutralized, or electric energy is converted into heat. If the potential difference across the ends of the conductor is π and if no other energy except heat is generated, we will have, if we call the heat quantity formed from electric energy " W ,"

$$W = Q \pi .$$

Considering also the time $\frac{W}{t} = q$,

we have $q = \frac{Q \pi}{t} .$

As $\frac{Q}{t} = i$ (intensity) and as according to Ohm's law $\pi = ir$, we can write

$$q = i^2r,$$

i.e., the rate at which heat is generated in a conductor is proportional to the resistance and to the square of the intensity. This is Joule's law.

Another important law of electrochemistry is Faraday's: All motions of electricity in electrolytes take place only with simultaneous motion of ions, so that with equal quantities of electricity chemically equivalent quantities of the various ions are moved. This law is correct for every kind of electricity-movement in conductors of the second class.

Of special interest for us is the transformation of chemical into electrical energy as we find it in galvanic batteries. It was thought at first that herein the chemical energy is perfectly transformed into electricity. This, however, is not correct.

In general we can express these conditions by the equation:

$$E_e = E_c + QT \frac{d\pi}{dt},$$

wherein E_e means electrical energy, E_c chemical energy, Q the quantity of electricity transferred in the electrolyte, π the potential difference and T the absolute temperature.

The radiant energy is the least known of any form of energy. Ostwald says in regard to the energy of radiation:

"The law of the conservation of energy shows a discrepancy, as we know some phenomena in which energy present disappears beyond the power of our senses and means of observation. It does not, however, disappear absolutely, as we can get back a quantity of energy equal to the amount lost. But in all these cases it can be proved that a certain (generally very little) time has elapsed during which the energy has left one part of the system under observation, but has not yet appeared in the other part. From the fact that the energy reappears after a certain time, we make the conclusion by analogy that it existed during this interval in a different form; as long as it was present in this form, it was imperceptible to

us until after its retransformation into one of the forms of energy that we can perceive with our senses."

This form, in which the energy has no connection with, and no relation to our senses, is called radiant energy or energy of radiation. By the regular relation between the disappearance of energy from one place and its reappearance at another place, we conclude that energy, if transformed into radiant form, travels through the space with a velocity of 3×10^{10} cm. per second. This is called the velocity of transmission of light (ray); it is correct, however, for radiating energy in general, from which light may originate. Electric energy is easily changed into radiant energy, which travels at the same speed, as energy originated from heat and chemical energy, which is generally called light. Based upon W. Weber's work Maxwell found, by comparing the formula for the electro-dynamic effect (long distance) and for the motion of light, that the principal constants are identical, and Hertz lately demonstrated by means of experiments that the periodical motions of radiant energy, through space, generated by rapid electric oscillations, are governed by the same law as the optical motions. To infer, therefore, as is done generally at present, that light is an electromagnetic phenomenon, is as incorrect as if one should conclude, from the fact that burning phosphorus emits light, that the light is a chemical phenomenon. We have, in all these cases, transformations of other forms of energy into radiant energy, that follow their own laws and can be recon-verted by proper means into every other form of energy.

Radiant energy can, as the other forms of energy, be produced from other forms of energy or changed into the same. Its relation to mechanical energy is the least known. It cannot be said with certainty at present whether direct change of the latter into radiant energy takes place at all. I was not able to find a single positive proof of this transformation. This is the cause of the fact that the mechanical energy, which acts in the movement of the stellar bodies, remains essentially unchanged, while the other formations which contain other kinds of energy, that are more easily transformed into radiation, do not show such a constancy. The transformation from radiant into mechanical energy has also not been proved beyond doubt; possibly such a transformation takes place in Crooke's radiometer.

Theoretically we should expect in every substance that yields radiant energy, a mechanical counter effect in the form of a pressure which works contrary to the direction of the radiation.

On the other hand a pressure in the direction of the radiation corresponds to every absorption of radiant energy. This pressure is equal to the radiant energy contained in unit volume. At the very great velocity of the radiation this amount is generally very small.

Contrary to mechanical energy thermic energy is very easily transformed into radiation. This change is so frequent and so regular that the thermic energy is often called "radiating heat." This name is as misleading as the definition of heat as a kind of motion; for the heat after transformation into radiant energy is not heat, just the same as mechanical energy, after transformation into heat, has ceased to exist as mechanical energy; in the new state the energy follows new laws and cannot be called by the old name.

The change of heat into radiant energy cannot be followed up in an absolute manner, since we have no means of measuring the radiant energy itself, being forced to convert the same into another form of energy; we have to reconvert it in this case into heat by placing in front of the radiant bodies, bodies absorbing the rays and transforming them into measurable heat. In other words the receiver has to be as sensitive a thermometer as possible. The receiver has to contain a certain heat of certain temperature, and must therefore also radiate, and the heat-quantity, which is perceptible on account of the absorbed radiation, is the difference between the latter and the emitted heat.

VOLUME I.
THE CHEMICAL TECHNOLOGY OF HEAT
AND FUELS.

VOLUME I.

THE CHEMICAL TECHNOLOGY OF HEAT AND FUELS.

THE chemical technology of heat treats of the methods used in the industries for the transformation of chemical energy into heat.

This transformation generally takes place by means of a chemical process called combustion, which in all commercial processes used up to the present time consists of oxidation. The oxygen required is taken either from the atmosphere or from oxides, the latter being thereby reduced. Lately experiments that look very promising have been made to produce pure oxygen on a large scale or to increase the oxygen content of the air for obtaining an increased effect in the combustion.

The materials which are used commercially for generating heat are called fuels. They are either used as they occur in nature (natural fuels) or are made to undergo certain changes before being used (artificial fuels).

The object of combustion, as above stated, is the transformation of chemical energy into heat. It will therefore be necessary to become acquainted with the methods of measuring the generated heat and also with the methods that enable us to determine the energy-content of the fuels.

Primarily, we are concerned with the measurement of the intensity factors of heat energy, *i.e.* the temperature, since the capacity-factors (the specific heats) are generally known, and hence do not have to be determined in every case.

Second in order comes the experimental determination of the calorific value. These determinations are of two kinds, depending on whether the quantity of heat yielded by the combustion of a certain quantity of fuel is to be determined, or whether the highest temperature that can be reached theoretically by combustion, is to be ascertained.

Finally it will be necessary to study in detail the process of combustion.

All these points are considered in Part I of this work. Part II contains the science of firing, *i.e.* all the processes that favor the utilization of the combustion heat, or reduce the unavoidable heat losses, and also the discussion of the different methods of industrial firing.

Part III is added as an appendix, treating of the various chemical methods of heat abstraction (refrigeration).

PART I.
HEAT MEASUREMENT, COMBUSTION
AND FUELS.

CHAPTER I.
THE MEASUREMENT OF HIGH TEMPERATURES
(PYROMETRY).

THE measurement of temperature is of the utmost importance in the industries, because on the one hand certain processes and reactions take place only within certain limits of temperature, and on the other hand an increase of temperature above a certain value means an increase of heat loss and a waste of fuel. Instruments for measuring temperature are generally called thermometers; thermometers used for measuring high temperatures, however, are called pyrometers. Widely different properties of certain substances which vary with temperature have been used or proposed for the measurement of temperature: Change of length and volume of various substances, variation in the pressure of gases and vapors, melting points of different substances, heat given up by hot substances in cooling, color of emitted light, change of electric resistance and thermoelectric behavior, heat-conductivity, etc.

We are going to describe below the most important instruments of this kind:

1. *Ordinary thermometers*, in which the apparent expansion of a liquid (generally mercury, at low temperatures, alcohol) in a containing glass vessel, is measured. Since the ordinary thermometers can be used only up to the vicinity of the boiling point of mercury (358° C. at atmospheric pressure), temperatures up to about 500° C. require instruments that contain a quantity of hydrogen or nitrogen above the mercury, instead of a vacuum. When used they have to be heated up slowly, *i.e.* gradually inserted into the medium or space, the temperature of which is to be measured.



For exact measurements of temperature the following errors have to be considered:

1. Reading error.
2. Graduation error.
3. Error due to pressure (inside or outside).
4. Error due to meniscus.
5. Erroneous determination of the fixed points.
6. Error due to time lag of thermometer.
7. Error due to glass-expansion.

We want to consider, in a few words, the most important of these sources of error.

To obtain correct readings the visual ray has to be perpendicular to the graduation.

For exact measurements of temperature it is a disagreeable fact that thermometers, after some time, show incorrect readings, the freezing point being apparently moved upwards, and returning to the original position only after being heated to high temperatures for several months. This phenomenon is called depression. This depression is in close relation to the composition of the glass:

TABLE II.
DEPRESSION FOR VARIOUS COMPOSITIONS OF GLASS.

Depression.	SiO ₂	Al ₂ O ₃	CaO	MgO	PbO	K ₂ O	Na ₂ O
Degree							
0.	50.83	1.04	0.52	27.98	11.08
0.08	72.04	2.42	8.20	1.63	15.32
0.09	65.42	0.93	13.67	19.46
0.09	69.04	0.89	12.21	18.52
0.10	56.74	0.66	0.18	29.86	12.48
0.11	65.00	2.04	13.58	19.51	0.07
0.12	72.09	1.45	11.20	0.12	1.88	13.41
0.15	69.52	3.86	9.13	0.71	3.07	13.77
0.20	64.48	1.48	5.68	12.71	3.55	12.81
0.24	70.29	2.29	9.55	14.51	2.48
0.31	75.65	1.34	6.11	5.68	11.50
0.35	74.72	1.35	9.10	5.86	9.03
0.36	66.42	3.35	10.70	0.30	14.55	4.57
0.37	66.55	1.31	13.37	15.50	3.07
0.40	63.47	1.77	10.10	12.24	11.95
0.40	60.56	1.14	10.21	3.52	24.45
0.48	68.30	1.28	10.41	8.27	12.08
0.61	70.29	2.49	8.68	12.06	5.38
0.66	72.44	1.60	9.23	11.29	6.00

TABLE III.
DEPRESSION FOUND BY WIEBE.

Depression.	SiO ₂	Fe ₂ O ₃	Al ₃ O ₃	CaO	MgO	Mn ₂ O ₃	As ₂ O ₃	K ₂ O	Na ₂ O
Degree									
0.04	64.45	0.81		12.36	0.22	Trace	0.89	20.09	0.86
0.15	64.66	0.53	0.24	13.38	0.27	Trace PbO	0.87	18.89	1.48
0.15	49.49	0.35		1.20	0.67	33.90 Mn ₂ O ₃	12.26	1.54
0.38	64.49	0.61	0.42	11.56	0.38	0.77	0.35	17.14	3.75
0.38	68.62	0.53	2.37	7.36	0.36	0.34	Trace	3.56	16.89
0.40	69.58	0.46	2.09	7.90	0.30	Trace	0.27	3.97	15.35
0.44	66.53	0.43	2.18	9.44	0.21	Trace	0.74	3.95	16.15
0.65	66.74	0.30	0.21	8.68	0.22	0.08	10.57	12.72
0.07	70.0	16.5	13.5
0.07	70.0	15.0	15.0
1.05	66.0	6.0	14.0	14.0

Other tests made by Abbe and Schott also proved that lead-potassium glass, potassium-lime glass or sodium-lime glass show the lowest depression, which, however, increases if potassium and sodium are present in a glass simultaneously.

According to these observations a standard-thermometer glass of the following composition is manufactured by Schott & Genossen in Jena:

Silicic acid	67 per cent
Boracic acid	2 per cent
Alumina.....	2.5 per cent
Lime.....	7 per cent
Oxide of zinc	7 per cent
Soda (caustic).....	14.5 per cent

This glass, after previously being heated to 100° C. shows a transient fall of the zero-mark of only 0.05 to 0.06° C.

The correction of the thermometer-reading on account of the meniscus is made by means of the equation:*

$$T = t + 0.000148 n (t - t'),$$

wherein *T* means corrected temperature.

t means observed temperature.

t' means average temperature of the meniscus.

n means length of the meniscus in thermometer-degrees.

* (See also the following table of Thorpe.)

TABLE IV.
VALUES OF THE CORRECTION FACTOR.

		0.000148 n (t - t')											
n	Deg.	10°	20°	30°	40°	50°	60°	70°	80°	90°	100°	110°	120°
10		0.01	0.03	0.04	0.06	0.07	0.09	0.10	0.11	0.13	0.14	0.16	0.17
20		0.03	0.06	0.09	0.11	0.14	0.17	0.20	0.23	0.26	0.29	0.31	0.34
30		0.04	0.09	0.13	0.17	0.21	0.26	0.30	0.34	0.39	0.43	0.47	0.51
40		0.06	0.11	0.17	0.23	0.29	0.34	0.40	0.46	0.51	0.57	0.63	0.69
50		0.07	0.14	0.21	0.29	0.36	0.43	0.50	0.57	0.64	0.72	0.79	0.86
60		0.09	0.17	0.26	0.34	0.43	0.51	0.60	0.69	0.77	0.86	0.94	1.03
70		0.10	0.20	0.30	0.40	0.50	0.60	0.70	0.80	0.90	1.00	1.10	1.20
80		0.11	0.23	0.34	0.46	0.57	0.69	0.80	0.92	1.03	1.14	1.26	1.37
90		0.13	0.26	0.39	0.51	0.64	0.77	0.90	1.03	1.16	1.29	1.42	1.54
100		0.14	0.29	0.43	0.57	0.72	0.86	1.00	1.14	1.29	1.43	1.57	1.72
110		0.16	0.31	0.47	0.63	0.79	0.94	1.10	1.26	1.42	1.57	1.73	1.89
120		0.17	0.34	0.51	0.69	0.86	1.03	1.20	1.37	1.54	1.72	1.89	2.06
130		0.19	0.37	0.56	0.74	0.93	1.12	1.30	1.49	1.67	1.86	2.04	2.23
140		0.20	0.40	0.60	0.80	1.00	1.20	1.40	1.60	1.80	2.00	2.20	2.40
150		0.21	0.43	0.64	0.86	1.07	1.29	1.50	1.72	1.93	2.15	2.36	2.57
160		0.23	0.46	0.69	0.92	1.14	1.37	1.60	1.83	2.06	2.29	2.52	2.75
170		0.24	0.49	0.73	0.97	1.22	1.46	1.70	1.94	2.19	2.43	2.67	2.92
180		0.26	0.51	0.77	1.03	1.29	1.54	1.80	2.06	2.32	2.57	2.83	3.09
190		0.27	0.54	0.82	1.09	1.36	1.63	1.90	2.17	2.45	2.72	2.99	3.26
200		0.29	0.57	0.86	1.14	1.43	1.72	2.00	2.29	2.57	2.86	3.15	3.43

0.000148 is an empirical coefficient that approaches the apparent expansion-coefficient of mercury in glass (0.000154).

2. *Graphite pyrometer and metal pyrometer.* Notwithstanding their defects these instruments are widely used. They are based upon the unequal expansion of two different solid substances, and they measure the difference of expansion of two different solid substances.

Especially the graphite pyrometer is largely used. However, it is not at all reliable, as is shown by the following table, in which t means the reading from the pyrometer and T the temperature determined by the Weinhold calorimeter:

TABLE V.

COMPARISON OF GRAPHIC PYROMETER WITH THE WEINHOLD CALORIMETER.

t	T	t	T	t	T	t	T
604	500	775	573	869	553	888	555
650	512	814	535	873	524	906	555
736	520	818	567	874	571	909	553
756	585	835	561	875	594	935	575

Furthermore, these pyrometers do not go back entirely to air-temperature after cooling, but show a temperature 20° – 60° higher, which defect increases continuously, so that three graphite pyrometers (examined by Beckert) that were only exposed to hot blasts of less than 500° C. within two months showed over 800° , and went to about 200° above the zero-mark.

Metal pyrometers show similar faults. With three of these pyrometers Weinhold obtained the following recorrections as compared with air-pyrometers. (Table VI.)

A peculiar instrument of this kind is Joly's meldometer, which is used for determining melting points.

3. *Wedgewood's pyrometer* is based upon the contraction of a clay cylinder, which, after being heated to the temperature to be measured, is allowed to cool to ordinary temperature; then the decrease of volume of the clay resulting from its change at high temperature is measured; one degree corresponds to a contraction of $\frac{1}{2400}$ of the original dimension. The zero-point of

the pyrometer corresponds to a temperature at which complete dehydration of the clay takes place, *i.e.* about 600° C. The contraction of the clay cylinder is measured by locating same between two graduated lines, which form a certain angle. (Fig. 1.)

TABLE VI.

COMPARISON OF VARIOUS METAL PYROMETERS WITH AN AIR PYROMETER. (WEINHOLD.)

(a) Gauntlett's Pyrometer (Iron and Brass).

First Series of Tests.		After Continued Use.	
Air Pyrometer.	Gauntlett Pyrometer.	Air Pyrometer.	Gauntlett Pyrometer.
Degrees	Degrees	Degrees	Degrees
507	325	407	310
13	-10	20	10
328	162	319	200
533	362	441	308
227	98	12	8
330	170	471	345
20	-10	348	220
.....	12	6
		0	-2

(b) Bock's Pyrometer (Iron and Brass).

Air Pyrometer.	Bock's Pyrometer.	Air Pyrometer.	Bock's Pyrometer.
Degrees	Degrees	Degrees	Degrees
305	125	347	225
464	245	478	210
472	250	565	330
526	298	716	400
636	352

(c) Oechsle's Spiral Pyrometer (Platinum-Silver).

Air Pyrometer.	Oechsle's Pyrometer.	Air Pyrometer.	Oechsle's Pyrometer.
Degrees	Degrees	Degrees	Degrees
277	325	257	275
272	315	15	-7
273	310	316	336
311	338	362	381
352	372	494	475
404	401	0	-52

These pyrometers are seldom used to-day, as they give widely varying results even with slight variations in their composition and method of manufacture; furthermore their results are not proportional to the ones of the air pyrometer, which at present is taken as standard thermometer.

LeChatelier found, for instance:

Air pyrometer ° C.

900 1000 1100 1200 1300 1400

Wedgwood's pyrometer

20 30 70 130 152 160

In ceramic factories, however, where not an actual temperature-measurement has to be made, but only a certain temperature has to be maintained, Wedgwood's pyrometer can be advantageously used. In France circular cakes 5 cm. thick, having a diameter of 5 cm., are used for this purpose, being pressed out of the clay-mass without moistening and then burned.

4. *Gas or air thermometers* are based upon Boyle-Gay-Lussac's law, and are considered as standard instruments, with which all others are compared. They are used either with constant volume or constant pressure.

For a permanent gas, which at the absolute temperature T and the pressure P , occupies the volume V , we have the law

$$PV = nRT$$

(wherein n stands for the number of mols of gas in volume V). If we change the temperature of this gas to T_1 , while keeping its volume constant, the pressure is changed to P_1 , and we have

$$P_1V = nRT_1,$$

or

$$\frac{T_1}{T} = \frac{P_1}{P},$$

or

$$\frac{T_1 - T}{T} = \frac{P_1 - P}{P}.$$

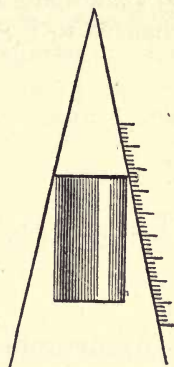

FIG. 1.—Wedgwood Pyrometer.

By this method we can measure a change of temperature by the corresponding change of the pressure.

If, however, we change the temperature of the gas from T to T_1 , keeping the pressure P constant, the volume of the gas is changed to V_1 , and we have

$$PV_1 = nRT_1,$$

or

$$\frac{T_1}{T} = \frac{V_1}{V},$$

or

$$\frac{T_1 - T}{T} = \frac{V_1 - V}{V}.$$

We measure here the change of temperature by the change of volume.

As the active medium a permanent gas is used (nitrogen, hydrogen, or air), which is enclosed in a vessel of practically unchangeable volume. The Celsius-graduation is used, the freezing point serving as zero-mark.

Temperatures between 0 degree and 100 degrees are generally measured with a thermometer of constant volume. Above 100° C. however, the pressure increases so rapidly that the strength of the pyrometer may be exceeded. Therefore for such temperatures instruments with constant pressure are used. If the pressure is measured in atmospheres we have for the first method

$$t = (P - 1) 273,$$

and for the second method:

$$t = \frac{V_1 - V}{V} 273.$$

Up to 500° C. the thermometer-vessel can be made of glass, but for higher temperatures glass softens. Platinum vessels were first tried for temperatures higher than 500° C., but not successfully, since hydrogen (which is generally used) permeates platinum at high temperatures. Porcelain vessels, if made impermeable for gas by glazing, can be used safely up to 1000° and even higher.

For avoiding the error due to the change of the quantity of the enclosed gas on account of the permeability of the vessel, a method invented by Becquerel can be used. It consists of forcing a further quantity of gas into the volume V of the pyrometer containing gas of the temperature (to be measured) T and of pressure P and measuring the pressure required for this purpose. Immediately before adding this quantity of gas we have in the apparatus n mols of gas of volume V , pressure P and temperature (to be measured) T ,

$$PV = nRT.$$

We now add the gas-volume v measured at t and p , for which we have

$$pv = n'Rt.$$

After pressing this gas-quantity in we have in the constant volume V of the apparatus, gas of the temperature (to be measured) T and of pressure P' :

$$P'V = (n + n') RT,$$

and therefore

$$\frac{PV}{T} + \frac{pv}{t} = \frac{P'V}{T}.$$

In this equation T is the only unknown quantity. We have

$$\frac{T}{t} = \frac{(P' - P)V}{pv},$$

or

$$T = \frac{(P' - P)V}{pv} t.$$

The applicability of this method is based upon the fact that less than a minute is required for measuring and introducing the additional quantity of gas so that the error caused by the permeability of the vessel during this short period is very small and negligible.

The only defect of this apparatus is the uncertainty of our knowledge (exactly) of the expansion of the pyrometer-vessel at high temperatures. An instrument of this kind, very convenient for practice, which, however, has to be handled carefully on account of the fragility of the porcelain vessel, was

constructed by T. Wiborgh. Figs. 2 and 3 show same in the older construction. The thermometer-bulb *V*, having a content of about 12 cm., is prolonged into a porcelain tube of 20 mm. outside and 0.5 mm. inside diameter. This tube, which is practically a capillary tube, and can be set upon the other parts of the instrument, has to be very strong, and is

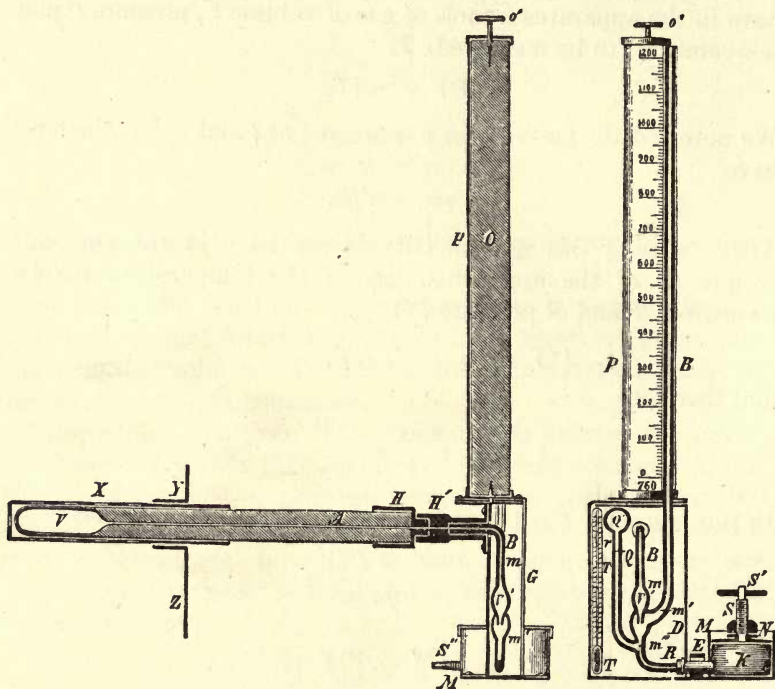

Figs. 2 and 3. — Wiborgh Pyrometer.

built with heavy walls. The tube is cemented into the metal shell *A*, which can be screwed upon the metal cylinder *H*, whereby a connection is made between the tube and the manometer *BV'B'*.

The glass tube (manometer) is somewhat larger (1.5 to 2 mm.) at *m* for a length of 10 mm.; then comes another enlargement containing the air volume *V'* that is to be pressed in the thermometer-bulb when determining the temperature. At *m'* the tube *B* opens into the longer manometer-tube *B₁*, which is

about 2 mm. inside and 8 mm. outside diameter. The latter is prolonged downward and connects through a bend with the iron vessel *K*, which is filled with mercury. A cover is screwed upon this vessel, the cover carrying a nut for the screw *S*, by means of which a second iron cover can be pressed directly upon the mercury.

The screw *S* is turned by means of the metal disk *S'*, which sets loosely upon the pivotal end of the screw so that the disk can easily be taken off. This is to prevent the mercury from being forced through the manometer-tube *B* into the thermometer-bulb by careless manipulation, which would injure the instrument. As further protection against such an accident the tube *B* is provided with another very small enlargement right above *m*, that is filled with asbestos to prevent a rise of the mercury beyond this point.

For protection the manometer-tube is enclosed in a little rectangular metal box *D*, closed in front by a glass plate *G*. The longer manometer-tube *B'* projects upward through the box along the metal tube *P*. The metal tube *P* contains a wooden cylinder *O*, which can be turned by knob *O'*. The scale is fastened to this cylinder, and is observed through a slot in the metal tube *P*. By turning the cylinder the correct scale, *i.e.* the scale corresponding to the barometric height, can be brought into view. For preventing dust from entering the open manometer-tube *B'*; some cotton is put into the upper end, above which a glass cap may be suspended. If the air-volume *V'* is at the same temperature as the thermometer-bulb and the mercury is forced up to the mark *m*, and rises in the manometer-tube *B'* to a certain height, it indicates the zero-mark of the instrument corresponding to the barometric height.

The correct scale is then brought into position by turning the scale-cylinder until the scale, whose zero-mark coincides with the barometric height, comes into view. If, however, the instrument is so placed that *V* is warmer than *V'*, it is not possible to find the correct scale by this method.

For avoiding the necessity of using a special barometer in this case, a third tube *Q*, terminating with a bulb *Q'*, is connected to the manometer-tube *R*. When the mercury is pressed into the manometer it is also pressed into *Q* and rises to

the zero-mark of the instrument, at a certain height r , marked on the glass. Here the same principle is used as in the pyrometer in general, *i.e.* a certain volume of air is pressed into another; if we have the same temperature in the tube Q and in the bulb Q' , the zero-point of the pyrometer can be determined by mark r , even if V is warmer than V' .

For protecting the lower part of the porcelain tube A , which contains the thermometer-bulb, from quick changes of temperature and shocks, it is packed in asbestos. The upper part, however, is free.

For cementing the pyrometer and manometer-tubes into their respective metal shells, a cement obtained by mixing finely powdered litharge with glycerin to a thick paste is used. This cement gets hard in a few hours, and can be heated up to about 250 degrees without being decomposed. In order to prevent the obstruction of the capillary tube during the cementing process, a metal wire is passed through both tubes; then the ends of the tubes are partially withdrawn from the metal shells and coated with cement. About half an hour later the superfluous cement is removed and the metal wire taken out.

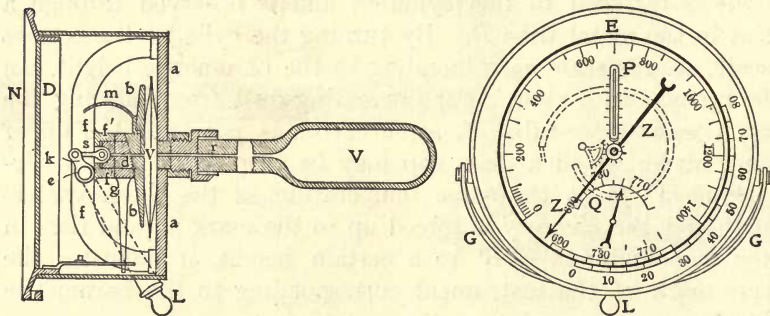

FIGS. 4 and 5. — Spring Manometer.

In order to render the instrument less fragile and to simplify its manipulation Wiborgh replaced the mercury-manometer by a spring-manometer (Figs. 4 and 5). The instrument rests in a round metal box with heavy bottom (a), to which the porcelain pyrometer-tube (rV) is screwed, the same as in the other instruments. In the interior of the box is a lenticular shaped metal vessel V' , which can be pressed together, and will regain its original shape when the pressure is released.

Facing plate a is a metal plate b , held in position by a cylindrical bearing; it is provided with a capillary tube. As the lenticular shaped vessel contains openings corresponding to the two capillary tubes, V and V' are brought into communication with each other and with the outer air.

A metal support, fastened to the box, carries a shaft e , which serves to compress the vessel V_1 through a short lever-arm K , which is connected to the rod s . By turning the shaft the opening in the capillary tube is closed and the plate b pressed against the lenticular vessel V' , compressing the air and forcing it into the bulb V of the pyrometer.

The capillary tube in the hub d is connected with the manometer-spring by means of a fine lead tube m . By means of geared wheels the spring transmits to a pointer the motion caused by the increased pressure.

The shaft e is turned by means of a forked lever-arm provided with a knob L .

If no measurement of temperature is being made the air-volumes V and V' are in communication with the atmosphere, and the rod s does not close the capillary tube. A spiral spring (not shown in the figure) is arranged to hold the lever in the position shown in Fig. 4.

The temperature-scale of the instrument is arranged for air-temperature of 0° C. If the latter is t° , the air-volume to be pressed into the pyrometer-bulb is simply increased to $(1 + at)V'$, whereby the same value is obtained as if t were 0° C. A change of the barometric height H has the opposite effect, so that V' has to be decreased as the barometric pressure increases if the scale is to give correct readings. Temperature and barometric height, according to the law of Boyle-Gay-Lussac, bear a certain fixed ratio to each other, so that, for instance, to compensate for an increase of the barometric height of 78 mm., the volume V' has to decrease as much as though the temperature had fallen 30 degrees. Therefore one single scale can be used for reducing the volume V' .

To accomplish this result the bearing d is provided with a movable collar g , one end of which presses against a projection of f , while the opposite end is helical in form, and fits a corresponding helix on the pivot plate b . By turning the cover of the instrument, which is connected with the ring by

the rods n and o , the collar g is raised or lowered, whereby a change of volume of the vessel V' is effected.

In addition to the scale of temperature (0° to 1400° C.), the dial of the instrument is provided with a small aneroid barometer Q , a thermometer P , a scale (from 690 to 790 mm.) for correcting the barometric pressure, and a temperature correction scale attached to a ring E . Correction for temperature and barometric pressure (*i.e.* setting the instrument to the air-temperature and pressure), is made by reading the thermometer P and the barometer Q , then turning the ring E so that the temperature and barometric readings on both scales coincide.

If a measurement of temperature is to be made, first of all the ring E is turned into the right position, *i.e.* the instrument is set to correspond with the air temperature and barometric height. Then the lever C is drawn forward as far as possible, until the pointer Z stops moving and stands still. Then the rod s is pressed down, the opening of the capillary tube closed and the hub d pressed down with the metallic disk; the vessel V' is compressed so that the air is pressed into the pyrometer-bulb V . The air-pressure so obtained is transmitted through the lead-tube m to the manometer-spring. The latter then changes its position and sets the hand Z in motion.

After reading the temperature the lever G is released. It jumps back, partly on account of the elasticity of the vessel V' , partly because of the spiral spring that is fastened to the shaft e ; and the pointer goes to the zero-mark. This measurement can be performed in a few seconds.

The lever-arm G (which is forked and elastic) can easily be taken off the shaft and removed, thus preventing the use of the instrument by unskilled persons.

In order to render the porcelain tube less fragile, and to be able to expose the tube directly to high temperatures without danger of cracking and breaking, it is covered with asbestos and packed into a sheet-iron tube, the latter being coated with fire-clay, quartz and unburned clay.

Both constructions of Wiborgh's air-pyrometer can be bought from Dr. Geissler's successor in Bonn.

Of the other practical air-pyrometers we may mention the pyrometer of K. V. Karlander (can be bought from Otto Meyer-

son in Stockholm) and of A. Sieger and Walter Duerr (can be bought from Alphonse Custodis in Düsseldorf).

The air-thermometer is not only used in practice, but also to a great extent as a standard for calibrating other instruments. For this purpose a number of very exact temperature-determinations were made with the air-thermometer, a number of which are given in Table VII:

TABLE VII.

ACCURATELY DETERMINED BOILING AND MELTING POINTS.

Substance.	Boiling Point.	Substance.	Boiling Point.
	Deg. Cent.		Deg. Cent.
Naphthalin.....	218	Sulphur (Regnault)	448
Mercury.....	357	Zinc.....	921
Sulphur.....	445		

Substance.	Melting Point.	Substance.	Melting Point.
	Deg. Cent.		Deg. Cent.
Cadmium.....	321.7	Silver (in air).....	955
Lead.....	326.9	Silver (pure).....	961.5
Zinc.....	419.0	Gold.....	1063.5
Antimony.....	630.6	Copper (in air).....	1064.9
Aluminium.....	657	Copper (pure).....	1084.1

The specific heat of platinum between 0° and 1200° C. was also found by calorimetry:

$$C_0^t = 0.0317 + 0.000006 t.$$

t was determined by means of an air-pyrometer.

Daniel Berthelot has lately by an ingenious method eliminated the error caused by the permeability and expansion of the casting, by determining optically the density of the heated air at atmospheric pressure, and therefrom calculating the temperature by means of the gas-equation. By this method he found

The melting point of silver to be 962° C.,

The melting point of gold to be 1064° C.,

which agrees exactly with the values given above.

5. *Klinghammer's thalpotasimeter* (Fig. 6). This instrument, which can be used up to about 800 degrees, measures the vapor tension of different liquids. It consists of a tube containing

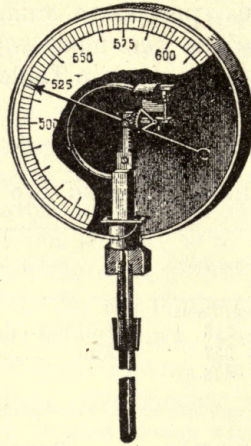

FIG. 6. — Thalpotasimeter (Klinghammer).

the liquid and a manometer. The following substances are used as the active medium:

	Deg. Cent.	
Liquid carbon dioxide.....	From - 65	to + 12.5
Liquid sulphur dioxide.....	- 10	+ 100
Ether (free of water).....	+ 35	+ 120
Distilled water.....	+ 100	+ 226
Heavy hydrocarbons.....	+ 216	+ 360
Mercury.....	+ 357	+ 780

Mercury is especially suitable, since its molecules consist of single atoms, which make the internal work very simple.

This pyrometer has to be gradually heated to the temperature to be measured, in order to prevent injury to the apparatus.

CHAPTER II.

PYROMETRY (*Continued*).

6. *Pyrometers in which the fusibility of different substances is utilized for measuring temperatures.* All these pyrometers have the disadvantage of only allowing the determination of constant or rising temperatures or of temperature-maximums; but they are not suitable for the observation of temperature-changes (up and down), which are frequently of commercial importance.

(a) Princep's alloys:

These are alloys of gold and silver, or of gold and platinum, the melting point of which was determined by Erhard and Schertel by means of an air-pyrometer. These determinations are shown in Table VIII.

The error of these determinations of the melting point is generally less than 20 degrees, but in most cases it is very much smaller. The above melting points were actually measured up to 1400° C. by the air-thermometer; the higher values were determined by graphic interpolation by using the melting temperature of platinum as found by Violle.

An important requirement for temperature-determinations by this method is the use of sufficiently pure metal for Princep's alloys. It is, therefore, of advantage to prepare them in a state of sufficient purity or to obtain them from a reliable source. Erhard and Schertel obtained the pure metals as follows: The silver was precipitated from diluted ammoniacal solution by ammonium-sulphide; gold was, after precipitation by sulphate of iron, transformed into sodium-gold-chloride and from the solution the pure crystals precipitated by means of oxalic acid. For purifying the platinum, platinum-salammoniac was treated (according to Claus) with sulphuretted hydrogen-solution, for reducing iridium to sesquichloride. The sponge obtained from the platinum-salammoniac (free of iridium) was melted upon chalk in an oxyhydrogen-flame. The different

mixtures can advantageously be prepared by using wires made out of the pure metals. A $\frac{1}{2}$ mm. wire can be made even out of pure gold or silver. Then the length of wire required for each case is calculated. This is more convenient and more correct than direct weighing, since only from $\frac{1}{10}$ to $\frac{1}{6}$ gram of an alloy is required for a determination, and even if a larger stock of alloys is to be made, the preparation in small quantities will yield a more uniform product.

TABLE VIII.

MELTING POINTS OF ALLOYS.

Gold-Silver-Alloys.

Silver.	Gold.	Melting Point.
Per cent.	Per cent.	Deg. Cent.
100	954
80	20	975
60	40	995
40	60	1020
20	80	1045
.....	100	1075

Gold-Platinum-Alloys.

Gold.	Platinum.	Melting Point.
Per cent.	Per cent.	Deg. Cent.
100	1075
95	5	1100
90	10	1130
85	15	1160
80	20	1190
75	25	1220
70	30	1255
65	35	1285
60	40	1320
55	45	1350
50	50	1385
45	55	1420
40	60	1460
35	65	1495
30	70	1535
25	75	1570
20	80	1610
15	85	1650
10	90	1690
5	95	1730
.....	100	1775

The alloys are made by melting the metals upon chalk by means of a blow-pipe-flame, which gives sufficient heat for the silver-gold alloys; for melting the platinum-gold alloys a gas-oxygen flame or a flame obtained by blowing oxygen into a burning mixture of 2 volumes ether and 1 volume alcohol has to be used. For preventing the volatilization of gold, the platinum-gold alloys are melted as far as possible with the ordinary blow-pipe flame, and then for complete melting exposed for a few seconds to an oxygen-blast.

The molten metal beads when quickly cooled show a fine crystalline structure, and when slowly cooled a coarse crystalline surface of netlike structure. They have a remarkable inclination for demixing (separating), which is accompanied by the production of a yellow color, both after slowly cooling and after heating for some time at a temperature near the melting point. In this case the hammered surface is crystalline, and shows a yellowish instead of gray color. The alloys with from 15 to 40 per cent of platinum show this variability frequently to a marked degree; they have then to be remelted in the oxy-hydrogen-flame. The alloys of gold and silver also become crystalline under these conditions, but their surface remains smooth and shows only more or less brilliant parts.

After melting the alloys are beaten flat with a hammer and exposed to the temperature to be measured in a cupola made of fire-clay mixed with quartz. Direct contact with reducing flames has to be avoided, otherwise a thin coating of slag is formed which considerably lowers the melting point. Experiments have shown that in such a case an alloy containing 47 per cent of platinum, that should melt at 1364°C ., showed a melting point of only 1247 degrees. This is probably due to the absorption of silicon, and therefore it is necessary, if a reducing flame is to be used, to use a cupola-base free of quartz, *i.e.* either of pure magnesia or pure clay.

(b) Seger-cones:

These are mixtures of quartz, kaolin, white marble and felspar, and are prepared by moistening the dry mixture with a solution of arabic gum, forming it into triangular pyramids 6 cm. high, the sides of the base being 1.5 cm. long. For lower temperatures part of the kaolin is replaced by ferric oxide. The "cones," provided with a number at the top, are put into

a chamotte-dish, which is brought into the room of which the temperature is to be measured. The point at which the "cone" begins to soften (at which the sinking apex touches the chamotte-base) is taken as melting point. At higher temperature the entire cone melts together into one mass.

TABLE IX.
COMPOSITION AND MELTING POINTS OF SEGER-CONES.

No.	Chemical Composition in Equivalents.	Composition.					Melting Point. Deg. Cent.
		Fel-spar.	Marble.	Quartz.	Ferric Oxide.	Kaolin.	
1	0.3 K ₂ O (0.2 Fe ₂ O ₃) } 0.7 CaO (0.3 Al ₂ O ₃) } 4 SiO ₂	83.55	35.00	66.00	16.00	1150
2	0.3 K ₂ O (0.1 Fe ₂ O ₃) } 0.7 CaO (0.4 Al ₂ O ₃) } 4 SiO ₂	83.55	35.00	60.00	8.00	12.95	1179
3	0.3 K ₂ O (0.05 Fe ₂ O ₃) } 0.7 CaO (0.45 Al ₂ O ₃) } 4 SiO ₂	83.55	35.00	57.00	4.00	19.43	1208
4	0.3 K ₂ O } 0.7 CaO } 0.5 Al ₂ O ₃ , 4 SiO ₂	83.55	35.00	54.00	25.90	1227
5	0.3 K ₂ O } 0.7 CaO } 0.5 Al ₂ O ₃ , 5 SiO ₂	83.55	35.00	84.00	25.90	1266
6	0.3 K ₂ O } 0.7 CaO } 0.6 Al ₂ O ₃ , 6 SiO ₂	83.55	35.00	108.00	38.55	1295
7	0.3 K ₂ O } 0.7 CaO } 0.7 Al ₂ O ₃ , 7 SiO ₂	83.55	35.00	132.00	51.80	1323
8	0.3 K ₂ O } 0.7 CaO } 0.8 Al ₂ O ₃ , 8 SiO ₂	83.55	35.00	156.00	64.75	1352
9	0.3 K ₂ O } 0.7 CaO } 0.9 Al ₂ O ₃ , 9 SiO ₂	83.55	35.00	180.00	77.70	1381
10	0.3 K ₂ O } 0.7 CaO } 1.0 Al ₂ O ₃ , 10 SiO ₂	83.55	35.00	204.00	90.65	1410
11	0.3 K ₂ O } 0.7 CaO } 1.2 Al ₂ O ₃ , 12 SiO ₂	83.55	35.00	252.00	116.55	1439
12	0.3 K ₂ O } 0.7 CaO } 1.4 Al ₂ O ₃ , 14 SiO ₂	83.55	35.00	300.00	142.45	1468
13	0.3 K ₂ O } 0.7 CaO } 1.6 Al ₂ O ₃ , 16 SiO ₂	83.55	35.00	348.00	168.35	1497
14	0.3 K ₂ O } 0.7 CaO } 1.8 Al ₂ O ₃ , 18 SiO ₂	83.55	35.00	396.00	194.25	1526
15	0.3 K ₂ O } 0.7 CaO } 2.1 Al ₂ O ₃ , 21 SiO ₂	83.55	35.00	468.00	233.10	1555
16	0.3 K ₂ O } 0.7 CaO } 2.4 Al ₂ O ₃ , 24 SiO ₂	83.55	35.00	540.00	271.95	1584
17	0.3 K ₂ O } 0.7 CaO } 2.7 Al ₂ O ₃ , 27 SiO ₂	83.55	35.00	612.00	310.80	1613
18	0.3 K ₂ O } 0.7 CaO } 3.1 Al ₂ O ₃ , 31 SiO ₂	83.55	35.00	708.00	362.00	1642
19	0.3 K ₂ O } 0.7 CaO } 3.5 Al ₂ O ₃ , 35 SiO ₂	83.55	35.00	804.00	414.40	1670
20	0.3 K ₂ O } 0.7 CaO } 3.9 Al ₂ O ₃ , 39 SiO ₂	83.55	35.00	900.00	466.20	1700

The melting points given were found as follows:

No. 1 melts at a little higher temperature than the alloy with 90 per cent gold and 10 per cent platinum (melting point according to Erhard and Schertel 1130° C.); its melting point was therefore assumed to be 1150° C.

No. 20 melts at a lower temperature than platinum; the melting point was therefore estimated to be 1700° C.

Assuming, furthermore, that the melting points of the 20 cones followed each other at equal intervals (which is actually not correct) the interval between two melting points following each other is calculated thus:

$$\frac{1700 - 1150}{19} = 28.9 \text{ degrees.}$$

Composition of the pyrosopes of higher numbers of Seger are given in Table X.

TABLE X.

COMPOSITION OF PYROSCOPES OF HIGHER NUMBERS. (Seger.)

Nr	K ₂ O	CaO	Al ₂ O ₃	SiO ₂	
21	0.3	0.7	4.4	44	} Difference: 0.5 Al ₂ O ₃ , 5 SiO ₂ .
22	0.3	0.7	4.9	49	
23	0.3	0.7	5.4	54	
24	0.3	0.7	6.0	60	
25	0.3	0.7	6.6	66	} Difference: 0.6 Al ₂ O ₃ , 6 SiO ₂ .
26	0.3	0.7	7.2	72	
27	0.3	0.7	20	200	
28	1	10	
29	1	8	
30	1	6	
31	1	5	
32	1	4	
33	1	3	
34	1	2.5	
35	1	2.0	
36	1	1.5	
38	1.0	

Cramer has made melting cones for measuring lower temperatures in the brick industry. They can be bought in two sizes (6 and 10 cm. high) from the Royal Porcelain Factory in Charlottenburg or from the Chemical Laboratory for Clay Industry, Berlin, N. W., Kreuz str. 6.

TABLE XI.
COMPOSITION OF PYROSCOPES FOR LOW TEMPERATURES.

Nr	Molecules.						
	K ₂ O	CaO	PbO	Al ₂ O ₃	Fe ₂ O ₃	SiO ₂	B ₂ O ₃
01	0.3	0.7	0.3	0.2	3.95	0.05
02	0.3	0.7	0.3	0.2	3.90	0.10
03	0.3	0.7	0.3	0.2	3.85	0.15
04	0.3	0.7	0.3	0.2	3.80	0.20
05	0.3	0.7	0.3	0.2	3.75	0.25
06	0.3	0.7	0.3	0.2	3.70	0.30
07	0.3	0.7	0.3	0.2	3.65	0.35
08	0.3	0.7	0.3	0.2	3.60	0.40
09	0.3	0.7	0.3	0.2	3.55	0.45
010	0.3	0.7	0.3	0.2	3.5	0.5
	Na ₂ O						
011	0.5	0.5	0.8	3.6	1.0
012	0.5	0.5	0.75	3.5	1.0
013	0.5	0.5	0.70	3.4	1.0
014	0.5	0.5	0.65	3.3	1.0
015	0.5	0.5	0.60	3.2	1.0
016	0.5	0.5	0.55	3.1	1.0
017	0.5	0.5	0.50	3.0	1.0
018	0.5	0.5	0.40	2.8	1.0
019	0.5	0.5	0.30	2.6	1.0
020	0.5	0.5	0.20	2.4	1.0
021	0.5	0.5	0.10	2.2	1.0
022	0.5	0.5	2.0	1.0

C. Bischof, who thoroughly investigated these pyroscopes, found even the highest melting point far below that of melting platinum. The melting points of Nos. 13, 14, 15 and even 17 are only slightly above that of melting palladium (1500° C.); furthermore these pyroscopes show various irregularities among themselves. However, notwithstanding these defects the Central Association of German Manufacturers recommended the official adoption of the Seger-cones, March 28, 1904.

The table on following page contains some new data relative to the melting temperatures of all these cones (measured with Le Chatelier pyrometer).

Only the following of these melting points are correctly determined: Nr. 022 melts at dark red glow, Nr. 010 at the melting point of silver, Nr. 1 near the melting point of an alloy containing 90 per cent gold and 10 per cent platinum, Nr. 10 at

the point where felspar begins to soften, and Nr. 36 at about the melting point of platinum. The other temperatures are only approximate.

TABLE XII.
MELTING POINTS OF PYROSCOPES.

Nr.	Deg. Cent.	Nr.	Deg. Cent.	Nr.	Deg. Cent.
022	590	02	1110	19	1510
021	620	01	1130	20	1530
020	650	1	1150	21	1550
019	680	2	1170	22	1570
018	710	3	1190	23	1590
017	740	4	1210	24	1610
016	770	5	1230	25	1630
015	800	6	1250	26	1650
014	830	7	1270	27	1670
013	860	8	1290	28	1690
012	890	9	1310	29	1710
011	920	10	1330	30	1730
010	950	11	1350	31	1750
09	970	12	1370	32	1770
08	990	13	1390	33	1790
07	1010	14	1410	34	1810
06	1030	15	1430	35	1830
05	1050	16	1450	36	1850
04	1070	17	1470	38	1890
03	1090	18	1490

7. *Calorimetric pyrometers.* With these instruments the temperature is derived from the quantity of heat that is given off by a heated body when cooling off in the calorimeter. This method was strongly recommended by Pouillet, Régnault, Carnelley, Violle and others, and introduced into industrial practice by Weinhold, Fiodier and others.

In order to reduce the radiation heat losses from the calorimeter to a minimum, the instrument is so designed that it becomes only slightly heated. In an apparatus to be used for scientific purposes the temperature rise of the calorimeter is measured by a mercury thermometer comprising 2 degrees and divided into $\frac{1}{10}$ degrees.

At first an iron cylinder was used as the thermometric substance, *i.e.*, the substance which gives off the heat to be measured in the calorimeter. The use of iron, however, proved to be

unsatisfactory on account of its easy oxidation and of its non-uniform cooling. If we take the heat given off and the temperature as co-ordinates, we obtain a curve with two points of inflexion, corresponding to the allotropic change of state of the iron. This shows that the temperatures calculated could not be correct.

This is the reason why platinum substances and a mercury-thermometer divided in $\frac{1}{100}$ degrees are used in laboratories, and in the industries a nickel-cylinder (the heating of this metal is very regular) and a mercury-thermometer divided in $\frac{1}{10}$ degrees whose scale, therefore, can be larger. A rise of about 50° C. in the calorimeter-temperature is sufficiently exact for practical purposes. The nickel-cylinder is put into a small pipe of fire-proof material, fitted with a removable iron handle. After the pipe with the cylinder has been in the furnace whose temperature is to be measured for fifteen minutes, one can be sure that equilibrium of temperature has been established. The pipe is now taken out of the furnace, emptied into the calorimeter, the calorimeter-water stirred and the increase of temperature read and recorded.

The following tests made by the Compagnie Parisienne du Gaze show the regularity of the heating law for nickel:

$$t C_0^t = \begin{matrix} 50.5 & 63.5 & 89.5 & 103 & 117.5 & 134 & 150 & 166 \\ t = 400^{\circ} & 500^{\circ} & 700^{\circ} & 800^{\circ} & 900^{\circ} & 1000^{\circ} & 1100^{\circ} & 1200^{\circ} \end{matrix}$$

We give below a few melting temperatures determined by Violle and also by Holborn and Day.

TABLE XIII.
MELTING POINTS OF METALS.

Metal.	Viole.	Holburn and Day.
	Degrees	Degrees
Silver.....	954	961.5
Gold.....	1045	1064
Copper.....	1055	1065
Palladium.....	1500	1500
Platinum.....	1779	1780

Below we describe a few pyro-calorimeters that were constructed for practical use.

The latest type of Weinhold's pyrometer for determining high temperatures is illustrated in Fig. 7. The calorimeter-vessel proper *CC* is made of thin sheet brass. It holds about 1 Kg of water, is cylindrical at the bottom and conical at

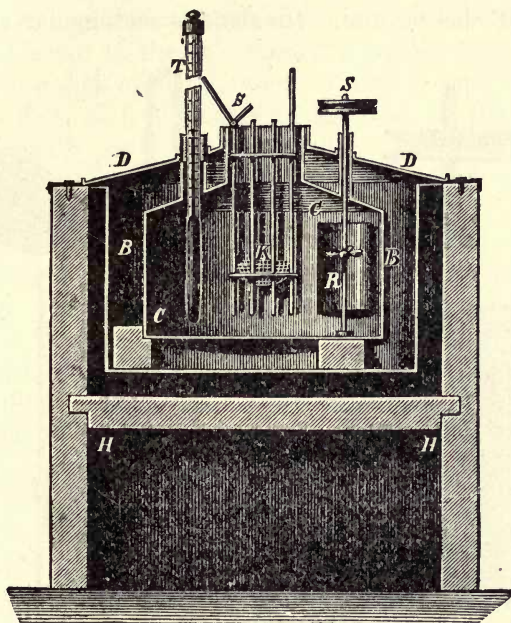

FIG. 7. — Weinhold's Pyrometer.

the top. The ratio of the height to the diameter is so chosen as to make the surface as small as possible, in order to reduce to a minimum the loss or gain of heat by radiation or conduction. A cylindrical vessel of tin-plate *BB* with a loose conical cover *DD* surrounds the calorimeter-vessel, which is carried by three cork-pieces, cemented into *BB*, and so arranged as to maintain a space of 1 cm. between the walls of the containing vessel and the calorimeter. *BB* is fastened in a wooden box *HH*. As wood and still air are very poor conductors of heat, and as bright sheet metal prevents radiation of heat, by this method an excellent heat-insulation is effected. The center

one of the three cylindrical openings in the calorimeter-vessel serves for introducing the metal ball, which is bored through in three directions perpendicular to each other. The thermometer *T* is inserted through a cork in the shortest neck. The shaft of the circulating device *R* is inserted through the narrow neck. This device (Fig. 8) consists of an impeller with six inclined paddles which move in a slim brass tube, open at the top and the bottom. Its shaft is rectangular at the top,

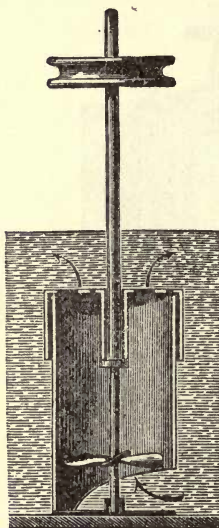

FIG. 8. — Circulating Device (for 7).

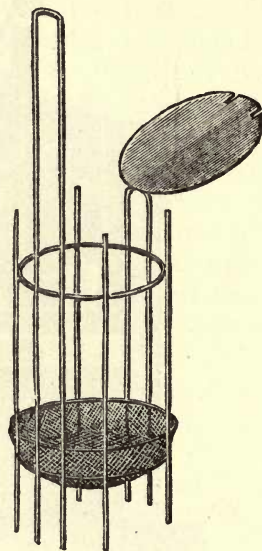

FIG. 9. — Brass Wire Basket.

so that the pulley *S* can be attached. By means of a cord passing over three guide-pulleys and a crank wheel, attached to the outside of the wooden box, *R* can be rapidly rotated. The lively circulation of water caused thereby facilitates the equalization of the temperature in the calorimeter. The thermometer *T* is provided with a scale divided in 0.1 degrees, on which, however, 0.01 degrees can be estimated. The thin cylindrical mercury-reservoir of the thermometer (50 to 60 mm.'s long) extends nearly the entire height of the calorimeter. The hot metal ball is kept in the brass-wire basket (Fig. 9). Its cover can be turned around a hinge, and is provided with a pin attached rectangularly downward. If the basket — with

the cover open — is let down into the neck of the calorimeter, the cover — and also the basket — remain hanging upon the edge of the neck. If now the ball is allowed to fall through the neck, it hits the pin and thereby closes the cover. This causes the basket with the ball to fall upon the bottom of the calorimeter, so that finally the cover almost touches the surface of the water, which, before putting in the basket and the ball, should reach to the lower edge of the neck. To assure the right amount of water in the calorimeter, a pipette is used, which is fastened to a disk of metal, wood, or cork, so that its lower end is exactly flush with the entry of the neck to the calorimeter. At first water is put in until it stands a few millimeters high in the neck, then the disk of the pipette is laid upon the edge of the neck and the excess water sucked out.

By throwing the hot ball into the calorimeter not only the water contained in the latter but also the calorimeter-vessel is heated up. To determine the quantity of heat absorbed by the instrument, the quantity of heat absorbed by the vessel has also to be considered. This is done by ascertaining the quantity of water that would be necessary to absorb the same quantity of heat as the calorimeter, *i.e.*, by determining the water-value of the calorimeter. For this purpose the brass calorimeter-vessel, together with the stirring arrangement and the basket *K* (but without the pulley *S* and thermometer *T* with cork) is weighed in a dry state. The weight found, multiplied by the specific heat of brass (0.095), gives the water-value of the empty calorimeter. The water-value of the thermometer is difficult to find, but can be neglected on account of the small quantity involved. After inserting the thermometer with the cork the apparatus is weighed a second time, and finally after putting in the cooling water it is weighed for the third time. The difference of the second and third weight gives the water content of the calorimeter. The water-value of the filled calorimeter is the sum of this water content and the water-value of the empty calorimeter. If, for instance, the empty calorimeter without thermometer weighs 210 g., with thermometer 236 g., with water 1240 g., we have:

$$\begin{aligned} \text{Water value of the empty calorimeter} &= 210 \times 0.095 = 19.95 \text{ g.} \\ \text{Water content of the calorimeter} &= 1240 - 236 = 1004.00 \text{ g.} \\ \text{Water value of the filled calorimeter} &= 1004 + 19.95 = 1023.95 \text{ g.} \end{aligned}$$

The water-value of the empty calorimeter is more conveniently determined by putting into the instrument a weighed quantity of water, then throwing in a test ball of a certain temperature (for instance 100° C.) and measuring the increase of temperature. If we divide the heat given off by the ball by the increase of temperature and deduct therefrom the weight of the calorimeter, we obtain the water-value of the dry instrument.

The balls used weigh from 60 to 80 g. For introducing them into the space, the temperature of which is to be measured, a pair of tongs made of heavy iron wire or bar iron, provided with cup-shaped jaws, is used (Fig. 10), or a spoon with cover, and fitted

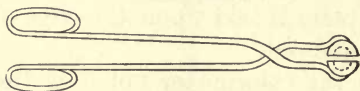

FIG. 10. — Tongue.

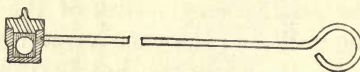

FIG. 11. — Spoon.

with a long handle (Fig. 11). The weight of the ball has to be determined before use. If the balls are of the size mentioned it is sufficiently accurate to weigh to the nearest decigrams.

When using, the calorimeter is filled with fresh water, the wire basket put in, and — immediately before inserting the ball — the circulation device is started, and kept in motion until the thermometer shows a constant temperature, which is read and recorded (initial temperature of the calorimeter). When introducing the ball, care has to be taken not to injure the thermometer and the driving cord of the circulation device. Directly after throwing in the ball, the circulation device is worked until the thermometer becomes stationary when the temperature (final temperature) is read and recorded.

The difference between initial and final temperature multiplied by the water-value of the filled calorimeter — expressed in kilograms — gives the heat-quantity (in calories) transmitted from the ball to the calorimeter. Therefrom the quantity of heat given off by a 1 Kg. ball is calculated, and by comparing this figure with a table in which the heat (c. t.) is calculated from the specific heat of the metal, the temperature is found.

Considerably simpler in construction is the calorimeter of Dr. Ferdinand Fischer (Fig. 12). The cylinder *A*, which is made of thin copper plate and has a diameter of 500 mm., is suspended

in the wooden base *B*. The space between both is filled with fibrous asbestos or mineral wool. The apparatus is closed by a thin brass or copper plate, having a large opening *d* (20 mm. diam.) for the stirrer *c* and for throwing in the metal cylinder, and a small opening for the thermometer *b*, which is a normal thermometer built by Geissler in Bonn. It has a very small mercury reservoir; its scale has a range of from 0° to 50° C., and is divided into 0.1 degrees, so that 0.01 degrees can easily be estimated; a strap *a* of thin copper plate protects it from being

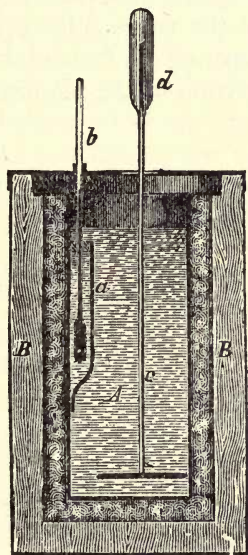

FIG. 12. — Fischers Calorimeter.

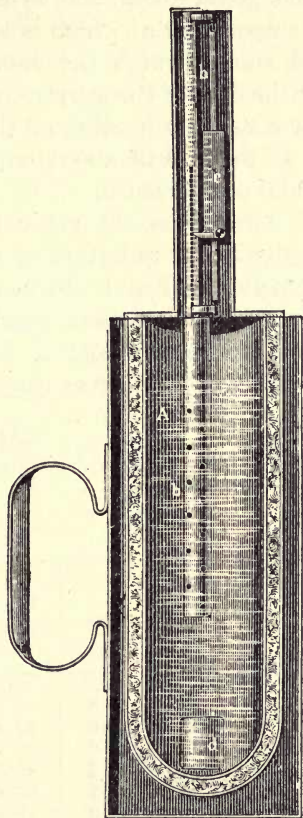

FIG. 13. — Siemens Water Pyrometer.

broken by the stirrer. The stirrer consists of a round copper disk, soldered to a copper rod. The latter is melted into a glass rod, that serves as handle. If, for instance, the copper vessel weigh 35.905 g., the stirrer without glass rod weigh 6.445 g., then the water-value of the calorimeter is $0.094 (35.905 + 6.445) = 3.98$ g., including the thermometer about 4 g. If the calorimeter water weigh 246 g., the water-value of the filled calorimeter is 250 g.

One of the simplest and oldest but also most widely used instruments is the water-pyrometer of C. H. Siemens (Fig. 13). It consists of a copper vessel *A* holding 568 cu. cm. of water. In order to reduce the loss by radiation it is surrounded by two vessels, one being filled with felt, the other being empty. The mercury thermometer is protected by a perforated metal-shell and has besides the ordinary scale a movable brass scale *c* (similar to a vernier), that gives the temperature directly without calculation. After filling the calorimeter with water the zero mark of the pyrometer-scale is set upon the temperature of water, as shown by the mercury thermometer. A hollow copper cylinder of a certain heat-capacity is now exposed in the medium, the temperature of which is to be measured, and after remaining there 10 to 15 minutes is thrown into the calorimeter-water.

The temperature required is obtained by adding to the temperature read off the pyrometer-scale *c*, the temperature of the calorimeter-water. The manipulation of this instrument is therefore extremely simple, naturally at the expense of accuracy.

For calculating the temperatures the following data of the heat capacities of platinum, iron and nickel from 0 degrees to *t* degrees can be used.

CHAPTER III.

PYROMETRY (*Conclusion*).

OPTICAL METHODS OF MEASURING TEMPERATURES.

THE instruments used for this purpose are based upon the relation between temperature and emission of light from heated substances.

(a) If a substance is gradually heated up, it starts at a certain temperature to emanate light-rays, the brightness of the latter increasing with the temperature. The color of the emanated light changes in a definite manner with the temperature. In many industries, after some practice, the approximate temperature of a furnace can be estimated with the naked eye without any instruments, from the brightness of the glowing walls and the heated substances.

The oldest data relative to the temperature of these so-called glow-colors were given by Pouillet.

The temperatures of the glow-colors have been determined by means of a Le Chatelier-Pyrometer, by Maunsel White and F. W. Taylor, and by Howe. The table on following page contains the results of these investigations.

The extreme rays of the spectrum show plainly the changes of brightness and color; but the yellow rays in the center, on account of their brightness, cover up all the others. The experiment was therefore tried of absorbing the latter by means of blue cobalt-glass. A glowing substance, viewed with such a glass, appears at relatively low temperature very red, and at high temperature strongly blue; thence with this method more reliable results are obtained than with the naked eye.

(b) The optical pyrometer of Mesuré and Nouël (Figs. 14, 15) can be obtained from E. Ducretet in Paris.

The direct observation of the glow-colors is rather difficult since it depends on individual qualification and momentary disposition. The eye can never determine the color shades with

absolute exactness, being only able to estimate by comparison. In a dark furnace-room the dark red of a melting metal can easily be taken as bright red, and vice versa in a light room, so

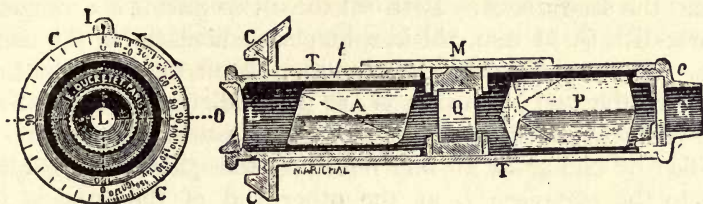

FIGS. 14 and 15. — Lunette Pyrométrique (Pyroscope).

that the result of such observation varies according to observer, light and time of observation.

TABLE XV.

TEMPERATURES CORRESPONDING TO GLOW COLORS.

Pouillet.		Howe.		White and Taylor.	
Heat Color.	Deg. Cent.	Heat Color.	Deg. Cent.	Heat Color.	Deg. Cent.
		First trace of visible red	470		
		{ in dark			
		{ of visible			
		{ red	475		
Beginning glow.	525			
Dark red glow..	700	550	Dark red	566
Beginning cherry red.	800	625	Dark cherry...	635
Cherry red.....	900	Full cherry red.....	700	Cherry red.....	746
Bright cherry red.	1000	Bright red.....	850	Bright cherry..	843
Dark yellow....	1100		Orange.....	899
Bright yellow... 1200		950	Bright orange .	941
		Full yellow.....	1000	Yellow.....	996
White glow.....	1300	Bright yellow.....	1050	Bright yellow..	1079
Bright white....	1400	White glow.....	1150	White glow....	1205
Dazzling white } 1500		
} to		
} 1600		

The object of the pyrometric tube of Mesuré and Nouël is the correction of this defect; it allows the determination of the

temperature of a substance by simple observation and enables us to determine more distinctly the shade of the color.

The apparatus is based upon the phenomenon of circular polarization and consists mainly of two Nicol-prisms, the polarizer *P* and the analyzer *A*. Between these two prisms is arranged a quartz-disk *Q*, 11 mm. thick, split perpendicularly to the main-axis. At the zero position of the instrument the planes of incidence of the two Nicol-prisms are perpendicular to each other. The correctness of the position of the prisms can easily be verified by taking off *M*, and removing the quartz-disk. Opposite to the eye-piece *L* at the other end of the tube is the objective *G*, consisting of a plane-glass or a well-polished diverging glass.

The following phenomenon can be observed by looking with this apparatus towards a source of light. After passing through the Nicol-prism *P* the light is polarized. Without a quartz-plate, *i.e.* with the second (perpendicular to the first) Nicol-prism following the first, this polarized light would be reflected by the cut surface of the Nicol-prism, and the field of view would appear dark. The quartz-plate, however, causes a turning of the plane of polarization that is proportional (according to Biot's law) to the thickness of the quartz-plate and approximately inversely proportional to the wave length of the ray (light). Thereby certain colors of the spectrum are extinguished by interference, and a mixed color is observed in the apparatus, depending on the temperature of the luminous body. By turning the analyzer the mixed color is changed, and whenever the instrument is set upon the same color-shade the temperature of the substance under observation can be inferred from the position of the polarizer. For this purpose the analyzer inside the tube is made so that it can be rotated. For measuring the displacement angle the instrument has a fixed mark *I* and is provided with a scale that can be rotated with the eye-piece and the analyzer. Since the length of the wave of the emitted light varies with the temperature, by slowly turning the analyzer certain colors that are changing with the temperature of the luminous body can be observed. The change from one color to another corresponds to a certain displacement-angle, varying with the temperature of the glowing substance.

Hereby we arrive at a position where the color, by the slightest

further rotation, changes quickly from blue to red. Between these two colors is observed a purple-violet shade formed by the most extreme rays of the spectrum; this shade is characteristic for measuring the angle of displacement. (Another shade [lemon-yellow], between green and red, can also be used for this purpose.) The position of hand *I* on the graduated arc *C* gives the angle from which the temperature is figured.

For determining the scale of temperature Pouillet's data on glow temperatures and the melting point of silver (954° C.) and platinum (1775° C.) according to Violle are used.

TABLE XVI.
GLOW TEMPERATURE OF SILVER.

Heat.	Displacement.	Temperature, Cent.
	Degrees.	Degrees.
Color:		
Beginning cherry red.....	33	800
Cherry red.....	40	900
Bright cherry red.....	46	1000
Orange.....	52	1100
Yellow.....	57	1200
Bright yellow.....	62	1300
Bright white.....	66	1400
Dazzling white.....	69	1500
Dazzling white.....	71-72	1600
Dazzling white.....	73-74	1700
Sunlight.....	84	8000

Below are given the results of some measurements with this instrument:

TABLE XVII.
DATA ON POLARISCOPIC PYROMETERS.

(A) Measurements by the Author.	Angle.	Temperature, Cent.
	Degrees.	Degrees.
Bessemer steel in the pan.....	59	1260
Open-hearth furnace, empty.....	61.75	1290
“ “ “ after charging the above steel.....	59.5	1275
“ “ “ middle of charge.....	58.5	1245
“ “ “ towards end of charge.....	63.5	1340
Heating furnace.....	50.5	1050

(B) Measurements of J. Weiler in the Bessemer converter:

	Deg. Cent.
While blowing.....	1330
At the end.....	1580
Slag.....	1580
Steel in pan.....	1640
Preheated block.....	1200
Block under hammer.....	1080

Blast furnace for gray iron:

Beginning of melting zone.....	1400
Steel crucible furnace.....	1600
Brick kiln.....	1100
Heat colors: red heat.....	525
Cherry.....	800
Orange.....	1100
White.....	1300
Dazzling white.....	1500

(C) Measurements of Le Chatelier:

	Angle.	Deg. Cent.
	Degrees.	
Sun.....	84-86	8000
Gas-flame.....	65-70	1680
Red glowing platinum.....	40-45	800

To keep out side-light it is of advantage to fasten a protecting tube in front of the objective. For the determination of low temperatures a convergent lens is placed before the instrument.

(c) Temperature can also be judged from the proportion of the intensities of two certain kinds of rays (for instance red and green) that are emitted from the heated substance.

Table XVIII gives the difference of the emission of red, green and blue rays of different substances compared to a black substance.

Crova has constructed a pyrometer based upon these data; however, it requires very great care in manipulation.

(d) Analogously the intensity of a single ray of a certain wave length can be used for measuring temperature. One would think, at the first thought, that the intensity depends on the emitting

capacity of the glowing substance, this capacity varying widely as is shown by the above figures. Actually, however, with most substances the variation in the emission is equalized by the capacity of reflection, which varies in the opposite sense. Furthermore the capacity of emission of most of the substances used in the industries is not considerable.

TABLE XVIII.
EMISSIVE POWER OF VARIOUS SUBSTANCES.

	Deg. Cent.	Red.	Green.	Blue.
Magnesia.....	1300	0.10	0.15	0.20
Magnesia.....	1550	0.30	0.35	0.40
Lime.....	1200	0.05	0.10	0.10
Lime.....	1700	0.60	0.40	0.60
Oxide of chromium.....	1200	1.00	1.00	1.00
Oxide of chromium.....	1700	1.00	1.40	0.30
Oxide of thorium.....	1200	0.50	0.50	0.70
Oxide of thorium.....	1760	0.60	0.50	0.35
Oxide of cerium.....	1200	0.8	1.00	1.0
Oxide of cerium.....	1700	0.9	0.90	0.85
Welsbach mixture.....	1200	0.25	0.40	1.0
Welsbach mixture.....	1700	0.50	0.80	1.0

The Cornu-Le Chatelier optical pyrometer is based upon this principle (Fig. 16). The instrument takes the form of a tube, through which the glowing substance is viewed. A reflector

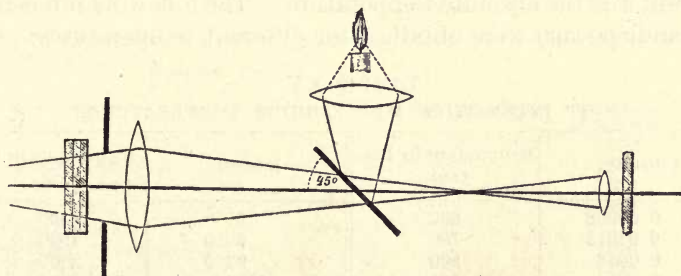

FIG. 16. — Optical Pyrometer (Cornu-Le Chatelier).

consisting of a glass-plate with parallel faces throws the image of a small flame into the eye-piece. A red glass in front of the eye-piece cuts off all but certain rays. Absorbing glasses can be put in front of the objective glass, so that only $\frac{1}{25}$ of the

incident light is allowed to go through. Between these glasses and the objective a transparent piece of onyx (Fig. 17) is inserted

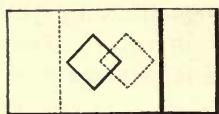

FIG. 17. — Piece of Onyx for Reducing the Light.

by means of which the light can be reduced at will. The observation is made by reducing the red light of the glowing substance, whose temperature is to be determined, by means of the darkening glasses and the onyx, until it is equal in brightness to the standard lamp. The apparatus is calibrated by direct comparison with an air-pyrometer. By this method the following intensities of light (red rays $\lambda = 659$) were measured:

TABLE XIX.
INTENSITIES OF LIGHT.

Red-glowing coal (600°)	0.0001	Melting palladium (1550)	4.8
Melting silver (950°)	0.015	Melting platinum	15
Stearine candle, gas burner	1	Incandescent lamp	40
Pigeon lamp	1.1	Arc light	10000
Argand burner with glass . . .	1.9	Sunlight (noon)	90000
Welsbach burner	2.05	Melting Fe_2O_3 (1350°) . . .	2.25

By this method at first a thermo-element was calibrated, by means of which the intensity of emission of black ferric oxide at different temperatures was determined. It was found that the law for the change of intensity of the red rays with the temperature can be expressed by the formula:

$$I = 10^{6.7} T^{-\frac{3210}{T}}$$

wherein T is the absolute temperature. The following intensities (in candlepower) were obtained for different temperatures:

TABLE XX.
LIGHT INTENSITIES FOR VARIOUS TEMPERATURES.

Intensity.	Temperature in Deg. Cent.	Intensity.	Temperature in Deg. Cent.
0.00008	600	39.0	1800
0.00073	700	60.0	1900
0.0046	800	93.0	2000
0.020	900	1800	3000
0.078	1000	9700	4000
0.24	1100	28000	5000
0.64	1200	56000	6000
1.63	1300	100000	7000
3.35	1400	150000	8000
6.7	1500	224000	9000
12.9	1600	305000	10000
22.4	1700		

As can be seen from this table the intensities increase rapidly. Hence, if in the determination of high temperatures an error of 0.1 candlepower is made in the measurement, the error in the temperature does not amount to more than from 2 to 3° C., which error can be entirely neglected.

The flame in the furnace must be avoided during the observation as otherwise incorrect results are obtained. This method is very good for measuring high temperatures, it is less exact, however, for low temperatures.

Le Chatelier made the following measurements with this instrument:

TABLE XXI.

TEMPERATURE DETERMINATIONS (Le Chatelier).

Open-hearth steel furnace.....	Deg. Cent. 1490 to 1580
Glass furnace.....	1375 to 1400
Porcelain furnace.....	1370
Porcelain furnace, new.....	1250
Incandescent lamp.....	1800
Arc light.....	4100
Sunlight.....	7600
Blast Furnace.	
At the tuyeres.....	Deg. Cent. 1930
Pig iron, beginning.....	1400
Pig iron, end.....	1520
Bessemer Process.	
Slag.....	Deg. Cent. 1580
Steel flowing into pan.....	1640
Reheating of ingot.....	1200
End of forging.....	1080
Open-hearth steel:	
Steel flowing, beginning.....	1580
Steel flowing, end.....	1420
Casting into form.....	1490

Féry has made some changes in this instrument.

Wanner's optical pyrometer is based upon the same principle. If we denote the intensity (of light) as I , the length of wave as

λ , the absolute temperature as T and two constants as c_1 and c_2 , we have, according to Wien:

$$I = \frac{c_1}{\lambda^5} e^{-\frac{c_2}{\lambda T}}.$$

As we have no absolute measure for the intensity, we can only compare same with another luminous body; for the latter we have

$$I_0 = \frac{c_1}{\lambda^5} e^{-\frac{c_2}{\lambda T_0}}$$

and therefore

$$\frac{I}{I_0} = e^{-\frac{c_2}{\lambda} \left(\frac{1}{T} - \frac{1}{T_0} \right)},$$

an equation containing only one constant. This equation is perfectly correct only for absolutely black bodies, but can also be used for measuring temperatures in a furnace — on account of the reflection going in all directions in the interior of the furnace.

When determining flame temperatures great care has to be taken. If the flame temperature is the same as that of the surrounding furnace-walls, this method can be used as it is; if, however, only glowing gases are present, colored for instance by sodium, correct furnace temperatures are not obtained except when the flame allows the rays used in the measurement to pass unabsorbed. Converter-gases are rather opaque to red (the color used in the Wanner pyrometer), especially so when many solid particles are burning in the flame. Hence too low a temperature will be obtained.

In the optical pyrometer the light is decomposed by a straight prism, and by means of a small slit nothing but the light corresponding to Fraunhofer's line c is allowed to go through. As, according to above equation, the measurement of temperature is based upon the comparison of two luminous substances, a small electric lamp is used as the standard luminous body. The lamp is attached to the front of the apparatus, and the light enters the instrument by means of a comparing-prism, while the light radiating from the glowing substance, whose temperature is to be measured, enters directly. The two intensities are compared by means of two Nicol-prisms, one of which (the

analyzer) can be turned with the eye-piece. The angle, that can be read from a circular scale, serves as the measure of intensity, while the corresponding temperature is read from a table. If a luminous body is viewed through the apparatus, the field of view appears divided into two halves of unequal brightness. The eye-piece is turned until both parts show the same brightness, the angle read and recorded and the temperature found from the table.

The entire apparatus, whose optical parts are manufactured by Franz Schmidt and Haenisch in Berlin, is about 30 cm. long, is shaped like a telescope and is easy to handle. Three storage batteries furnish the electricity for the little 6-volt lamp. Since the light-intensity of this lamp depends on the e.m.f. of the storage batteries, it is necessary to adjust the lamp from time to time by means of amyl-acetate lamps.

On account of the increasing weakness of light at low temperatures, 900° C. is taken as the lowest working point. The upper limit can be selected at pleasure.

TABLE XXII.

TEMPERATURE-MEASUREMENTS WITH THE WANNER PYROMETER.

(a) In blast-furnaces.

	Deg. Cent.	
Slag.....	1402	1370
Pig iron.....	1317	1284
Pig iron from mixer.....		1260
Pig iron flowing into converter.....		1240
Steel when turning converter.....		1460
Slag when turning converter.....		1555
Slag, flowing out.....	1424	1372
Pig iron, starting of flow.....	1384	1372-1330
Pig iron in a prismatic form.....		1230
Pig iron getting solid.....		1012
Slag from mixer.....	1384	1330
Slag from converter.....		1230
Pig iron from blast furnace.....		1225
Steel from converter.....		1211
Iron from cupola.....		1239

(b) Thomas-process. (Temperature of converter-gases during charge) 1310°, 1381°, 1472°, 1310°, 1331°, 1472° and 1494° C. The temperature of the converter is much higher. The temperature of the slag, three minutes after stopping the blower, was found to be 1700° C.

(c) Various measurements.

Zirconium in oxygen gas blast 2090° C.

Electric arc light with retort coal 3560–3610° C.

Of other optical pyrometers we mention the apparatus of Holborn-Kurlbaum and of Morse, in which the intensity of the electric standard lamp is varied.

The thermo-electric telescope of Féry (Fig. 18) is based upon the measurement of the total radiated energy of a glowing substance.

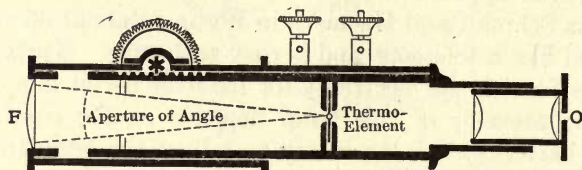

FIG. 18. — Féry's Thermo-electric Telescope.

The total radiation of energy of a substance according to the Stefan-Boltzmann law is:

$$E = K (T^4 - T_0^4).$$

In this equation E is the energy radiated from a black body at absolute temperature T° to a body of the temperature T_0° and K is a constant. The correctness of this law within the widest temperature limits was proved by Lummer, Kurlbaum, Pringsheim, Paschen and others. The following table gives the observations of Pringsheim and Lummer:

TABLE XXIII.
RADIATION OF ENERGY.

1	2	3	4	5	6
Black Body.	Absolute Temperature Observed.	Reduced Deflection.	$K \cdot 10^{10}$	Absolute Temperature Calculated.	T Observed— T Calculated.
Boiler (kettle).....	373.1	156	127	374.6	-1.5
Saltpetre kettle.....	492.5	638	124	492.0	+0.5
Do.....	723.0	3320	124.8	724.3	-1.3
Do.....	745	3810	126.6	749.1	-4.1
Fire brick furnace.....	810	5150	121.6	806.5	+3.5
Do.....	868	6910	123.3	867.1	+0.9
Do.....	1378	44700	124.2	1379	-1
Do.....	1470	57400	123.1	1468	+2
Do.....	1497	60600	120.9	1488	+9
Do.....	1535	67800	122.3	1531	+4
		Average	123.8		

The temperatures given in column 2 are referred to the temperature-scale of Holborn and Day, in which the thermo-electromotive force of the Le Chatelier-element (Pt + Platinum - Rhodium) is calibrated with a nitrogen-thermometer. Under column 3 we have the radiant energy of the black body at the observed temperature, measured bolometrically (and the galvanometer-deflection reduced to the same units). The bolometer temperature was 290° absolute. The following observations of Lummer and Kurlbaum show the anomalies that have to be considered with other than black bodies. (See the following pages.)

The radiant energy of ferric oxide is from 4 to 5 times as great as that of polished platinum, but nevertheless considerably smaller than that of a black body. With increasing temperature however the radiation of non-black bodies increases faster than that of absolutely black substances.

In Féry's thermo-electric telescope (Fig. 18) the image of the glowing surface whose temperature is to be measured falls upon the soldered joint of a copper thermo-element, a galvanometer being inserted in the circuit of the latter. The solder becomes heated, and the thermo-e.m.f. generated is measured by the galvanometer. The image of the glowing surface is thrown upon the solder by means of the eye-piece *O*. The objective *F* is made of fluor spar, which absorbs very little of the radiant energy. Some instruments are made with glass objectives.

TABLE XXIV.

RADIANT ENERGY OF VARIOUS SUBSTANCES.

Absolute Temperature.		$K = \frac{E}{T^4 - T_0^4}$		
<i>T</i>	<i>T</i> ₀	Black Body.	Polished Platinum.	Ferric Oxide.
372.8	290.5	108.9
492	290	109.0	4.23
654	290	108.4	5.56	33.1
795	290	109.9	8.14	36.6
1103	290	109.0	12.18	46.9
1481	290	110.7	16.69	64.3
1761	290	19.64

The following table shows the close agreement of results, determined with different optical pyrometers, used to measure the temperature of the electric arc light.¹

TABLE XXV.
COMPARISON OF PYROMETRICAL MEASUREMENTS.

Observer.	Absolute Temperature.	Method.
Le Chatelier.....	4370	Photometry: intensity of red light.
Violle.....	3870	Calorimetry: specific heat of coal.
Wilson & Gray.....	3600	Total radiation of cupric oxide (empirical equation).
Wanner.....	3700-3900**)	(According to the coal used) photometry; Wien's law.
Féry.....	3600-4000	Wave length of maximum radiation (Wien's law).
Lummer & Pringsheim..	3750-4200	do.....
Féry.....	3760**)	Total radiation; Stefan-Boltzmann's law.

** Temperature of the black body.

Methods based upon the change of electric resistance. Temperature can also be measured by the change in the electric resistance of a spiral platinum wire, wound around a rod of fire-clay and protected from the outside by a clay-vessel (Fig. 19).

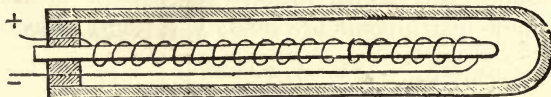

Fig. 19. — Spiral Platinum Wire (protected).

The law governing the relation between resistance and temperature is represented by a parabola. This principle was first used by Siemens, but soon abandoned in practice as the platinum is affected by silicon, phosphorus and the gases of reaction, whereby its resistance is considerably changed.

At first a platinum tube was put around the platinum wire, which made the apparatus too fragile and too expensive. It was soon found that a porcelain-tube would do just as well. The apparatus therefore is very apt to break, and is hardly used except for very accurate measurements in laboratories.

¹ Waidner & Burgess: The temperature of the arc (Phys. Rev. 19, Nr. 4).



TABLE XXVI.
COMPARISON OF PYROMETRICAL MEASUREMENTS. (Fischer.)

Pyrometer of			Mercury Thermometer (Geissler).
Steinle & Hartung (Graphite Pyrometer).	Siemens (Resistance Pyrometer).	Fischer (Calorimeter).	
Degrees.	Degrees.		
358	361
728	612
700	612	602
260	266	261
101	98	99.5
102	100	99.8
103	99	99.8
103	101	99.8
843	751	754
910	837
862	778	761
858	751
848	744	730
511	449	440
312	308	304
294	290	287

Upon the same principle are based the pyrometers of Hartmann and Braun in Bockenheim-Frankfurt am Main, of Callendar and others.

The results of some measurements with these instruments are given in Table XXVII:

TABLE XXVII.
MEASUREMENTS WITH HARTMANN AND BRAUN'S PYROMETER.

	Deg. Cent.
Melting point:	
Tin.....	232 (Callendar and Griffiths, Heycock and Neville)
Bismuth.....	270 Callendar and Griffiths.
Cadmium.....	322 Do.
Lead.....	329 Do.
Zinc.....	421 Do.
Zinc.....	419 Heycock and Neville.
Magnesium, 1% impurities.....	633 Do.
Antimony.....	629.5 Do.
Aluminium, 99.5% Al.....	654.5 Do.
Silver.....	960.5 Do.
Gold.....	1062 Do.
Copper.....	1080.5 Do.
K ₂ SO ₄	1084 Do.
K ₂ SO ₄ solidifying point.....	1067 Do.
Na ₂ SO ₄ melting point.....	902 Do.
Na ₂ SO ₄ solidifying point.....	883 Do.
Na ₂ CO ₃ , melting point.....	850 Do.

Henri Le Chatelier's thermo-electric pyrometer. This instrument is based upon the measurement of the current produced by heating the soldered joint of a thermo-element. The solder immediately reaches temperature-equilibrium with the body or space whose temperature is to be measured, and the instrument can be set at quite a distance from the place to be investigated, which is of considerable advantage.

The selection of the metals for the thermo-element is of importance. Iron or nickel cannot be used, as these metals, when heated at one point, set up local currents. Generally one wire is of platinum and the other of platinum containing 10 per cent of iridium or rhodium.

For measuring the current Le Chatelier uses a Deprez d'Arsonval aperiodic galvanometer fitted with a mirror and scale, or a needle-galvanometer, built according to his instructions by Pellin in Paris. Kaiser and Schmidt in Berlin and Siemens and Halske use needle-galvanometers.

According to the investigations of H. Le Chatelier the relation between the electromotive force and the temperature difference between the soldered joint and the extremity of an element consisting of platinum and palladium can be expressed by the equation:

$$e = 4.3 (t - t_0) + \frac{7.3}{1000} (t^2 - t_0^2).$$

He found $t - t_0 = 100^\circ \quad 445^\circ \quad 954^\circ \quad 1060^\circ \quad 1550^\circ$
 $e = 500 \quad 2950 \quad 10,900 \quad 12,260 \quad 24,030$

By using a thermo-element consisting of platinum and a plat-alloy, the equation takes a different form.

TABLE XXVIII.
MEASUREMENTS WITH THERMO-ELEMENTS.

Barus.		Le Chatelier.		Holborn and Wien.	
Pt - Pt 90 + Ir 10		Pt - Pt 90 + Rh 10		Pt - Pt 90 + Rh 10	
<i>t</i>	<i>e</i>	<i>t</i>	<i>e</i>	<i>t</i>	<i>e</i>
Degrees.		Degrees.		Degrees.	
300	2,800	100	550	100	565
500	5,250	357	2,770	200	1,260
700	7,900	445	3,630	400	3,030
900	10,050	665	6,180	600	4,920
1100	13,800	1060	10,560	800	6,970
.....		1550	16,100	1000	9,080
.....		1780	18,200	1200	11,460
.....		1400	13,860
.....		1600	16,220

All these observations when plotted show similar curves. For Le Chatelier's observation we have:

$$\log e = 1.2196 \log t + 0.302.$$

Wherein e is expressed in microvolts.

The best way is to calibrate the instrument by direct observations. For this purpose the data given in Table XXIX can be used.

TABLE XXIX.

DATA FOR CALIBRATING PYROMETERS.

	Deg. Cent.
Boiling point of water.....	100
Boiling point of naphthaline.....	218
Melting point of zinc.....	420
Boiling point of sulphur.....	445
Melting point of aluminium.....	655 (667)
Melting point of salt.....	800
Melting point of silicate of sodium.....	883
Boiling point of zinc.....	930
Melting point of silver.....	960 (961.5)
Melting point of gold.....	1045 (1064)
Melting point of palladium.....	1500
Melting point of platinum.....	1780

(The figures in parentheses were determined by Holborn and Wien).

The boiling points of water, naphthaline and sulphur are determined by heating the substances to the boiling point in an insulated glass tube closed at the bottom; then the soldered joint of the thermo-element is immersed in the vapor. The melting point of zinc is observed by enclosing the thermo-element in a porcelain tube (Fig. 20), and immersing it in the molten metal.

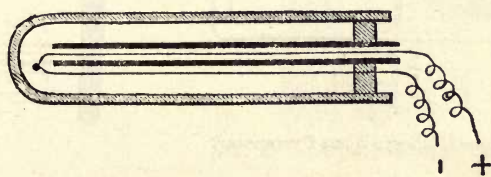

FIG. 20. — Thermo-element in Porcelain Tube.

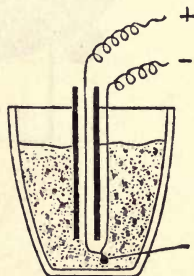

FIG. 21. — Crucible.

When determining the melting point of gold a few milligrams of gold are placed under the thermo-element, which is put into a crucible filled with sand (Fig. 21) and heated above 1000 degrees,

at the same time carefully watching the movement of the galvanometer. When the gold starts to melt, the galvanometer remains stationary until all the gold is melted, when the temperature continues to rise at a steady rate.

When measuring the temperature of steel-furnaces, etc., the thermo-element must be enclosed in an iron pipe. For porcelain-furnaces where temperature measurements are made constantly, the thermo-element, which is protected by a glazed earthenware pipe, is permanently attached to the furnace but does not extend into the interior of the furnace. It is heated by a specially arranged circular recess.

This instrument is made in Germany by W. C. Heraeus in Hanau, and by Kaiser and Schmidt in Berlin, as shown in Fig. 22;

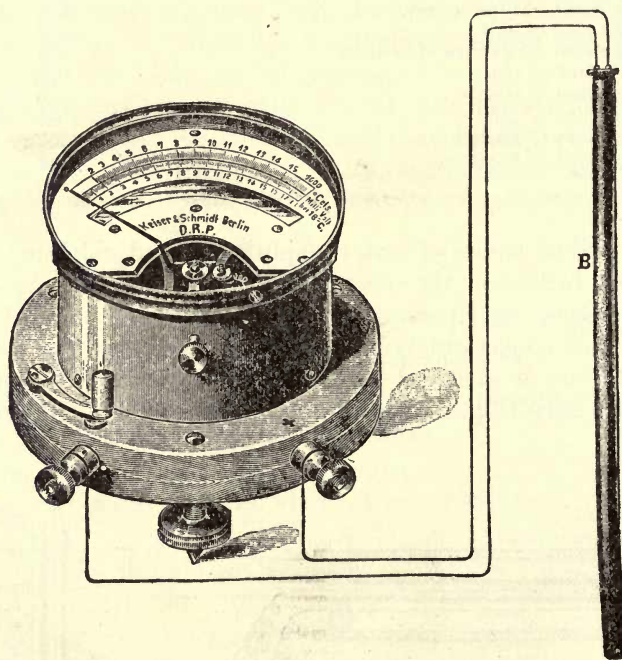

FIG. 22. — Holborn-Wien Pyrometer.

it is specially constructed for industrial use. In the report of the "physikalisch-technische Reichsanstalt," the advantages of the Holborn-Wien modification of the Le Chatelier pyrometer are

set forth; the reading of the instrument is so simple that a fairly intelligent workingman can learn, in a short time, how to use it. Furthermore the instrument is durable, the accuracy is not impaired by high temperatures, the reading apparatus can be at quite a distance from the furnace and one indicating device can be used for a number of thermo-elements.

The thermo-element consists of a pure platinum wire 0.6 mm. in diameter and 1500 mm. long, one end of which is melted together with the end of another wire consisting of an alloy of 10 per cent rhodium and 90 per cent of platinum. The purity of the metals used is of importance if the same thermo-electromotive forces are to be obtained. The opposite ends of the wire are connected to a circuit. By heating the solder a small e.m.f. is generated (about 0.001 volt per 100 degrees temperature difference between the soldered end and the free end). This e.m.f. is measured by means of a galvanometer provided with two scales, one graduated in microvolts, and the other in temperature-degrees. According to Holborn and Wien, the accuracy of the instrument at 1000° C. is 5° C.

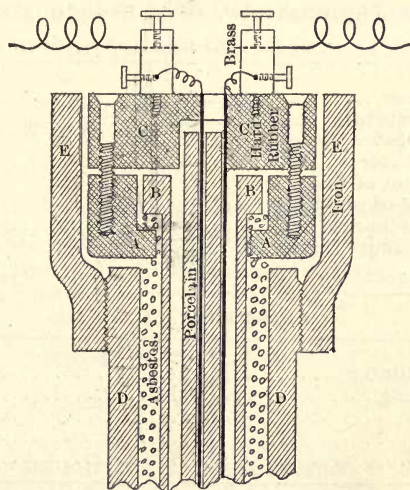

FIG. 23. — Arrangement of Element.

When in use the wires of the element must not come in contact with substances that react with platinum or its alloys. This is prevented by suitably mounting the instrument in a porcelain-

tube, which at the same time provides the insulation of the wires. These porcelain shells can stand temperatures up to 1600 degrees. Fig. 23 shows how the element is mounted. A hard rubber disk, having an opening in the center is slid from the bottom over the outer porcelain-tube. This disk has a recess which fits about the head *B* of the porcelain-tube. A layer of asbestos-cord is wound in between *A* and *B*. The upper hard rubber disk is provided with two small openings, through which the wires of the element are drawn and a recess for the porcelain insulating tube. The disk *l* is permanently connected with disk *A* by means of three brass screws. Two binding screws, which serve as terminals, are attached to *C*. Asbestos cord is wrapped around the outer porcelain-tube, the latter being forced into the iron pipe *D*. *D* is provided at the lower end with a removable cap and at the upper end with a bell *E* to which the hard rubber-head of the mounted element is fastened by means of three iron screws.

The temperatures of molten metals, slags, etc., are preferably determined with floating pyrometers of spheroidal shape.

TABLE XXX.
TEMPERATURE DETERMINATIONS, OPEN-HEARTH STEEL FURNACE.
(Le Chatelier.)

	Deg. Cent.
Gas leaving producer.....	720
Gas entering regenerator.....	400
Gas leaving regenerator.....	1200
Air leaving regenerator.....	1000
Flue gases at bottom of flue.....	300
Furnace, beginning of puddling.....	1550
Furnace, end of discharge.....	1420
Casting-pan, beginning.....	1580
Casting-pan, end.....	1490

GLASS FURNACE.

Furnace, during refining.....	1400
Glass, during refining.....	1310
Glass, during work.....	1045
Heating of bottles.....	585
Rolling plate-glass.....	600

ILLUMINATING GAS MANUFACTURE.

Furnace on top.....	1190
Furnace on bottom.....	1060
Retort at end of distillation.....	975
Flue-gases.....	680

The Hartmann and Braun pyrometer is based upon the same principle. The thermo-elements, up to 1000° C., consist of platinum and platinum-nickel, up to 1600° C. of platinum and platinum-rhodium. The nickel element is twice as sensitive as the rhodium element.

CERAMICS.

- Burning temperature of hard porcelain..... 1400° C.
- Burning temperature of china porcelain..... 1275° C.
- Burning temperature of bricks..... 1100° C.

Wiborgh's Thermophone (Fig. 24).

This consists of a fire-clay cylinder, containing a small copper-cartridge filled with dynamite. The thermophone is brought into the space, whose temperature is to be measured, and the length of time observed until an explosion takes place (light detonation). The temperature is then read from a table.

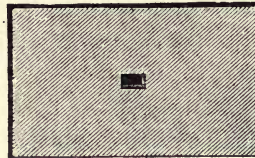

FIG. 24.

To ascertain the time required for heating the cartridge by heat-conduction to the explosion-temperature (150° C.), Fourier's equation is used:

$$y - \theta = (t - \theta) \left[1 - \frac{2}{\sqrt{\pi}} \int_0^\phi e^{-\phi^2} d\phi \right]$$

In this equation, t is the outside temperature; y , the temperature of a point in the interior, at a distance x from the surface after a time, z , and θ , the original temperature of the clay-body.

$$\phi = \frac{x}{2\sqrt{\frac{C}{cd}} z}$$

- C is the heat conductivity of the substance;
- c , the specific heat of the substance;
- d , the weight of 1 cu.m. of the substance, in kg., and
- z , time in hours;
- x , the distance of the point observed, from surface of test-body, in meters.

The thermophone has to be kept in a dry place, and when used, must have an initial temperature of from 18 to 22° C.

(a) When determining the temperature in reveratory- or muffle-furnaces, stacks, etc., or in all cases where the thermophone rests upon a solid base and is surrounded by hot gases, the time elapsing between the insertion of the thermophone and the explosion is read and the temperature taken from Table I.

(b) When determining the temperature of liquid metals, such as zinc, lead, copper, silver or gold, an iron pipe, closed at the bottom, 30 mm. inside, 34 to 36 mm. outside diameter, is inserted in the molten metal; after a few minutes, when the pipe has attained the same temperature as the metal, the thermophone is slid into the pipe. In this case the temperature is read from Table II.

(c) When measuring high temperatures of molten metal and slag, such as iron, steel, etc., the thermophone is thrown upon the surface of the metal and slag, and the temperature is taken from Table III. The above table is made out for $\theta = 20^\circ$ C. If the air-temperature differs from this a correction must be made according to equation:

$$t' - t = \frac{\theta - \theta'}{y - \theta} (t - y);$$

if $y = 150^\circ, \theta = 20^\circ,$

we have:

$$t' - t = \frac{20 - \theta'}{150 - 20} (t - 150) = \frac{20 - \theta'}{130} (t - 150).$$

If at an air temperature of $\theta' = 30$ degrees a temperature of 2000 degrees is found, the correction is

$$t' - t = \frac{20 - 30}{130} (t - 150) = -142^\circ,$$

and the measured temperature is $t' = 2000 - 142 = 1858^\circ$ C.

The results obtained with the thermophone are very satisfactory. Contact of the thermophone with basic slags has to be avoided, since in such cases the explosion takes place too early, which gives too high results.

TABLE XXXII.

COMPARATIVE DATA ON WIBORGH'S THERMOPHONE.

Temperature-Measurements.	Air Pyrometer.	Thermophone.
		Deg. Cent.
Heating furnace	784.5	772 764
Heating	875.0	888 878
Open-hearth steel upon acid slag		over 2400
upon steel		1812
upon strongly basic slag		over 2400

In practice automatic registering pyrometers are very useful as they make a continuous control of the temperature-changes possible. Because of lack of space they cannot be described in this book.

Suggestions for Lessons.

Practice in handling various pyrometers;
 Adjustment of same;
 Determination of melting points, heating and cooling curves;
 Comparative temperature-measurements with different pyrometers.

CHAPTER IV.

COMBUSTION HEAT AND ITS DETERMINATION.

HEAT value, fuel value, thermal value, calorific value or thermal efficiency is the quantity of heat developed from a certain quantity of fuel in complete combustion. It is generally expressed in calories.

This quantity is called absolute thermal value, etc., if it is referred to the unit of weights, specific thermal value, if referred to the unit of volume.

Pyrometric thermal efficiency is called the temperature that can theoretically be reached by combustion of the fuel.

We are going to speak first of the absolute thermal value or, chemically expressed, of the determination of the combustion-heat, which is generally figured in calories, sometimes however given in per cents of the thermal value of pure carbon, or as "evaporating-power," or in comparison with some other fuels, or as the quantity of lead reduced by 1 g. of fuel.

The expression of the thermal value in calories is easily understood as it means the number of large calories furnished by the combustion of 1 kg. of fuel. If this quantity is divided by 8080 (the thermal value of 1 kg. of charcoal according to Favre and Silbermann) the thermal value is obtained, expressed in terms of the heat-value of pure carbon.

The expression of the thermal value of a fuel by its "evaporating power" was first proposed by Karmarsch. It means the quantity of water transformed into steam by 1 kg. of fuel and is obtained by dividing the thermal value expressed in calories with 652 (the heat-quantity, necessary, according to Regnault, to transform 1 kg. of water at 0° C. into steam at 150° C.).

For certain purposes the thermal value of one fuel is compared with the value of another fuel, *i.e.* the fuel quantity equivalent to the other is given. Generally 1 cubic meter of soft logwood is taken as unity which has a thermal value of about 900,000 cal.

Table XXXIII will be useful for transformations.

TABLE XXXIII.
THERMAL TRANSFORMATION VALUES.

Thermal Value in		Evaporating Power.	Cubic Meter of Soft Logwood.
Calories.	Referred to 1 Kg. of Pure Carbon.		
1	0.00012376	0.0015337	0.000001111
8080	1	12.39	0.00898
652	0.080693	1	0.000724
900.000	111.4	1380	1

In determining the thermal value account has to be taken of the quantity of hydrogen present which is oxidized to water. According as we assume that this water is completely condensed or completely changed to steam, we obtain the highest and lowest calorific values, respectively.

The following methods have been proposed for determining the fuel value:

1. Direct determination of the thermal value.

- (a) On a small scale, in calorimeters.
- (b) On a large scale, in steam-boilers.

2. By means of empirical formula based on certain chemical tests.

- (a) Calculation of the thermal value from the chemical composition (elementary analysis).
- (b) Calculation of the thermal value from the quantity of oxygen required for complete combustion (Berthier's method).
- (c) Based on simple chemical tests.

(1) Direct determination of the thermal value. These methods undoubtedly give the best results. Several details have to be considered; all losses or gains of heat have to be avoided. This is easier accomplished in small than in large apparatus.

The determination of the thermal value on a small scale, however, has a disadvantage in that it is very difficult to get a good average sample small enough to be burned in a small apparatus. The only apparatus to be recommended are those in which a single reliable determination can be made simply and quickly,

so that a great number of determinations can be made on any one sample without difficulty.

We shall consider here only some of the most widely used calorimeters.

Of the calorimeters in which combustion with oxygen under atmospheric pressure takes place we shall describe only the calorimeter of F. Fischer (Fig. 25).

The oxygen for combustion is led (sometimes after being washed with caustic potash and dried) through the gas pipe *a* and the platinum pipe *r*. The latter is fitted loosely in the cover *e* of the combustion-chamber *A* (made of 95 per cent silver) and reaches into the platinum-crucible *t*, which contains about 1 g. of the fuel to be tested. The combustion gases escape through the platinum-net *u* and then upwards between crucible and ring *V* through *s*, *i* and *e* into the pipes *c* and *b*. The platinum-net *u*, upon which some soot is deposited, finally gets so hot that the soot is burned. The calorimeter-vessel *B*, which contains 1500 g. of water, is surrounded by a layer of mineral wool *C* and the wooden case *D*. The two thermometers *t* serve for measuring the temperature of the calorimeter water and of the escaping gases respectively; *w* is a stirrer, operated by *m* and the silk-cord *o*. By means of a magnifying glass one one-hundredth of a degree can be observed and recorded.

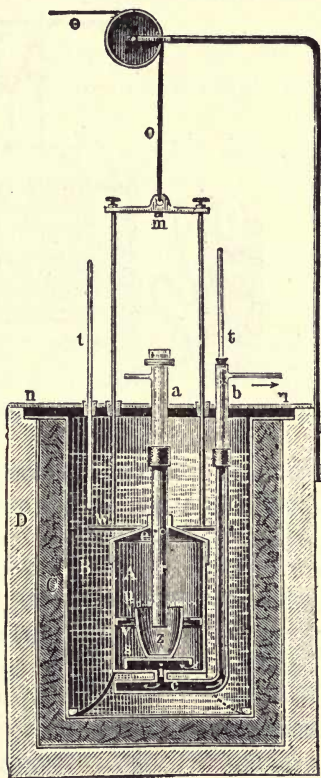

FIG. 25. — Fischer's Calorimeter.

Calorimeters in which combustion in oxygen takes place under pressure, as for instance the apparatus of Berthelot, Mahler, Stohman, etc., are very convenient. In all these methods the combustion of the fuel takes place in a closed chamber, in which the fuel is enclosed with a sufficient amount of compressed

oxygen. The increase of temperature of a certain mass of water (calorimeter-water) into which the apparatus is immersed, is observed and recorded.

The calorimetric bomb of Mahler is illustrated in Fig. 26 and consists of the following parts: (1) A bomb *B* made of excellent steel somewhat softer than gun-steel. This steel has an

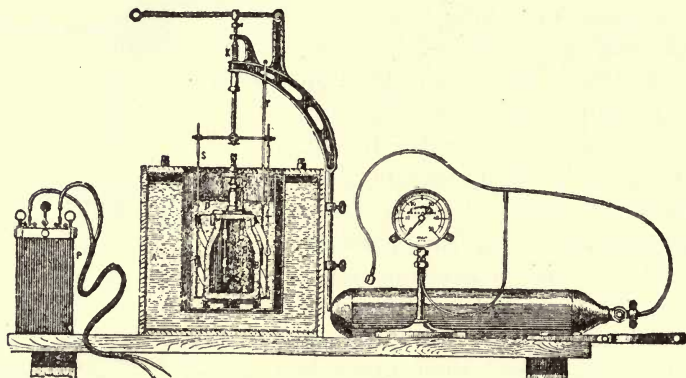

FIG. 26. — Calorimeter Bomb (Mahler).

absolute strength of 55 kg. per sq. mm. and 22 per cent elongation. The quality of the steel was carefully selected on account of the strength and also on account of the enameling, of which we will speak later.

The bomb has a capacity of 654 cu. cm. and its walls are 8 mm. thick. This capacity is much larger than that of Berthelot's bomb, the object being to obtain an oxygen surplus even when using a gas not entirely pure. Fuel-gases are also studied with this bomb. The fuel gases often contain as much as 70 per cent of inactive substances, which make it necessary to take considerable quantities when testing in order to obtain a measurable increase of temperature in the calorimeter.

The oval shape was selected in order to facilitate the forging and enameling. The bomb is nickel-plated on the outside, and coated with enamel on the inside to prevent any bad effects from nitric acid, which is always formed by combustion. This enamel takes the place of the platinum-lining in Berthelot's apparatus.

The bomb is closed with a threaded plug packed with sheet lead. The plug is provided with a taper threaded cock, which

serves as inlet for the oxygen and through which is inserted a well insulated electrode *E*, which is attached to a platinum rod *F* that extends towards the interior. Another platinum rod, also fastened to the plug, carries a platinum cap for receiving the fuel to be tested.

(2) The other parts of the apparatus are the calorimeter *D*, the calorimeter-jacket *A* and the stirrer *S*. They differ in details from Berthelot's apparatus and are less expensive.

The spiral-shaped stirrer of Berthelot is replaced here by a simple and easily operated circulation device which allows the production of a uniform circulation.

(3) We may further mention: the thermometer, which is divided in $\frac{1}{100}$ degree, the source of electricity *P* and a watch or minute-glass.

(4) Mahler uses oxygen from an oxygen-bomb. Since the most favorable pressure for burning 1 g. of bituminous coal is about 25 atm., and since the bombs contain 1200 liters (120 atm.), one of these vessels is sufficient for about 100 determinations. A pressure-gauge (manometer) inserted between the oxygen-bomb and calorimeter-bomb allows the pressure of the oxygen to be controlled.

The pressure used with solid and liquid fuels is 25 atm.; with gases rich in carbon (illuminating gas, etc.) 5 atm., and with poor gases (producer gas, etc.) 1 atm. To insure the complete combustion a certain excess of oxygen must be present; too great an excess, however, would lower the combustion temperature and thereby cause incomplete combustion.

The two insulated electric conductors which pass through the plug are connected inside the bomb by a spiral made of 0.1 mm. iron-wire, that extends into the fuel and causes ignition after the state of incandescence is reached.

The fuel is contained in a small vessel of platinum, which is connected in the electric circuit. In a bomb containing 650 cu. cm., 1 g. of fuel is used. Slightly volatile liquids can also be used directly.

When measuring gases the bomb is evacuated and filled with gas at certain temperature under pressure, which process is repeated twice for removing every trace of air.

It is necessary that the calorimeter-water and jacket water be in temperature-equilibrium with the air of the room. All the

apparatus is allowed to stand in the test room for 24 hours previous to the test, immersed in a sufficient amount of water. The apparatus has to be protected from the sun and from draughts, which will cause a variation of temperature.

The constants of the calorimeter are determined by burning a known quantity of a certain substance of known thermal value, for instance, 1 g. of naphthaline yielding 0.70 cal.

When making a determination, 1 g. of the powdered fuel is weighed and put into the small vessel. The powder should not be too fine, as otherwise it might be carried away by the current of oxygen. If a fine powder is to be used it is wrapped up in paper of known weight and known thermal value.

The bomb is closed and the oxygen allowed to enter slowly so as to avoid blowing away the powder. When the desired pressure is reached the cock is closed and the bomb cut off from the manometer. The bomb is put into the calorimeter, five minutes being allowed for equalizing the temperature. The vessel must be held upright to avoid spilling the powder. The stirrer is moved rapidly and continuously for three minutes in order to obtain a uniform temperature of the water, and the temperature of the calorimeter read and recorded.

The fuel is ignited by impressing 10 volts on an iron-wire; the temperature is read and recorded every minute for six minutes. The temperature equilibrium of the bomb and calorimeter is generally perfect after three minutes. The readings during the next three minutes are used to correct the heat lost by radiation.

It is generally sufficient to add to the increase of temperature recorded three minutes after ignition the decrease of temperature observed during the two following minutes. This is not absolutely correct, but sufficiently so for commercial purposes. The exact corrections give results varying not more than $\frac{1}{300}$ from the correction mentioned.

A second correction relates to the combustion heat of the iron-wire in oxygen, which amounts to 1.600 cal. per 1 g. iron, and to the heat liberated by the formation of a small quantity of nitric acid. The latter quantity has to be determined for very accurate work, but can be neglected in commercial tests, the error amounting to less than $\frac{1}{300}$ and being nearly compensated by the error in the correction for cooling. 1 g. HNO_3 yields by its formation 0.230 cal.

EXAMPLE: One g. of naphthaline is used for combustion.

Water-content of calorimeter.....	2200 g.
Water-value of bomb, etc.	480 g.
Total	2680 g.

Measurements of temperature:

Before Test.	Combustion.	Cooling.
0' 17.52°	3' 20.15	6' 21.09°
1' 17.52°	4' 21.06	7' 21.07°
2' 17.52°	5' 21.11	8' 21.09°

Rise in temperature observed.....	3.59°
Correction for cooling.....	0.04°
Total	3.63°

Quantity of heat, $3.63 \times 2.68 =$	9.728 cal.
Correction for iron, $0.025 \times 1.60 =$	0.040 cal.
Difference	9.688 cal.

If a correction for the nitric acid formed had been made the result would have been 9.685 cal.

Mahler found in a lecture, *i.e.* under conditions which prohibited the attainment of temperature-equilibrium in the calorimeter, 8373 cal. as the fuel-value of a bituminous coal, while in the laboratory, when taking all precautions, he obtained a value 1.3 per cent lower.

If the coal contains considerable amounts of sulphur, same has to be considered. The sulphur is completely oxidized to sulphuric acid and can be determined by well-known methods after washing the bomb with water. The other calorimeter-bomb, in which combustion is effected with oxygen under pressure, is arranged in a somewhat similar manner.

All determinations made in such apparatus have two defects. They give a thermal value at constant volume while in practice all combustion takes place at constant pressure; on the other hand they give the so-called upper thermal value, as the hygroscopic water of the coal, and the coal formed by combustion is cooled to air-temperature, *i.e.* condensed, so that the thermal value determined in the bomb includes the latent heat of evapora-

tion of the water, which can never be utilized in firing. To counteract this last defect Krocker proposes to put the bomb after combustion into an oil-bath at from 105° to 110° C., and to absorb the evaporated water in a calcium chloride apparatus; finally, to pass dry air through the bomb. Since he uses very exact corrections for the cooling of the calorimeter, we give an example of his method.

Temperature of the room 20 degrees.

Water in calorimeter	= 2100 g. }	2440 g.
Water value of the apparatus	= 340 g. }	
Weight of iron-wire and coal-brickette	= 1.0959 g.	
Weight of iron-wire alone	= 0.0187 g.	
Weight of coal-brickette alone	= 1.0772 g.	

Weight of the chloride of calcium apparatus:

(a) Before test	48.2169 g.
(b) After test	48.7605 g.
Weight of total water	0.5436 g.
Weight of water in O ₂	0.0250 g.
Weight of water in coal	0.5186 g. = 48%

TABLE XXXIV.
TEMPERATURE CHANGE.

No.	First Test.		Main Test.		After Test.		Note.
	Reading.	Difference.	Reading.	Difference.	Reading.	Difference.	
	$\tau =$	$v =$	$t =$	$t =$	$\tau' =$	$v' =$	
1	18.750	+	18.759	18.759	21.744	—	The coal was burned as furnished without being made air dry.
2	18.753	0.003	19.170	21.742	0.002	
3	18.753	0.000	20.530	21.739	0.003	
4	18.756	0.003	21.240	21.729	0.010	
5	18.756	0.000	21.590	21.720	0.009	
6	18.757	0.001	21.723	21.713	0.007	
7	18.758	0.001	21.749	21.749	21.707	0.006	
8	18.758	0.000			21.704	0.003	
9	18.759	0.001	Difference	2.990			
10	18.759	0.000					
Sum	187.759	0.009	173.798	0.040
Aver.	18.756	0.001	21.725	0.005

The temperature of the calorimeter water rose 2.990° C.

For correcting the temperature the formula of Regnault-Stohmann-Pfauneller is used:

$$\text{Corr.} = \frac{v - v'}{\tau' - \tau} \left(\frac{t_2 - t_1}{9} + \frac{t_1 + t_n}{2} + \sum_1^{n-1} (t) - n\tau \right) - (n - 1)v.$$

v means herein average of temperature-differences of the preliminary test.

τ means herein average of temperature-readings of the preliminary test.

$t_1, t_2 \dots t_n$ means herein the temperature-readings of the main test.

v' means herein average of temperature-differences of final test.

τ' means herein average of temperature-readings of final test.

n means herein number of readings of main test.

For our example we have:

$$v - v' = 0.001 + 0.005 = 0.006^\circ$$

$$\tau' - \tau = 21.725 - 18.756 = 2.969^\circ$$

$$\frac{t_2 - t_1}{9} = \frac{0.411}{9} = 0.046^\circ$$

$$\frac{t_1 + t_n}{2} = \frac{40.488}{2} = 20.244^\circ$$

$$\sum_1^{n-1} (t) = 123.002^\circ$$

$$n\tau = 7 \times 18.756 = 131.292^\circ$$

$$(n - 1)v = 6 \times 0.001 = 0.006^\circ.$$

The correction therefore is:

$$\begin{aligned} \text{Corr.} &= \frac{0.006}{2.969} (0.046 + 20.244 + 123.012 - 131.292) - 0.006 \\ &= 0.012^\circ. \end{aligned}$$

Corrected increase of temperature = 2.990 + 0.012 = 3.002°.

Heat generated in calorimeter

$$3.002 \times 2440 = 7324.8 \text{ cal.}$$

If we deduct herefrom 2.92 cal. (that are developed from 0.0187 g. iron-wire in combustion) we get the thermal value of the coal:

$$\frac{7324.8 - 29.9}{1.0772} = 6772 \text{ cal.}$$

For the acids formed Krocker deducts 8 cal. (as average), whereby the thermal value of the coal becomes:

$$\frac{7324.8 - 29.9 - 8}{1.0772} = 6764 \text{ cal.}$$

Altogether 0.5436 g. of water were absorbed by the calcium chloride. According to previous tests 0.025 g. of same come from the compressed oxygen, so that for the coal burned we have 0.5436 - 0.025 g. = 0.5186 g. of water (48 per cent of the coal burned). The latent heat of evaporation is:

$$0.48 \times 600 = 288 \text{ cal.}$$

so that we get as useful thermal value of the coal (lower heat-value)

$$6764 - 288 = 6476 \text{ cal.}$$

Since the quantity of hygroscopic water in coal varies widely, only dried coal should be used for the determination of fuel values. Furthermore since the determination of the water content of the calorimeter is a tedious operation, it is of advantage to determine the hydrogen content of coal by elementary analysis.

A calorimeter constructed by S. W. Parr, professor in the State University at Champaign, Ill., for determining fuel values is more and more widely used on account of its low cost. This calorimeter is based upon the same principle as the calorimeter-bombs, *i.e.* the combustion takes place in an enclosed space, so that during the process no gases can enter or escape. The oxygen is used in solid form and the products of combustion obtained are transformed into solid compounds, therefore combustion takes place at low pressure, and the expensive bomb is done away with.

Fig. 27 shows the assembled apparatus, Fig. 28 the reaction-vessel (the cartridge). The calorimeter proper consists of a nickel-plated copper-vessel *A*, which contains somewhat over 2 liters and a vessel *C*, made of wood fiber and surrounded by

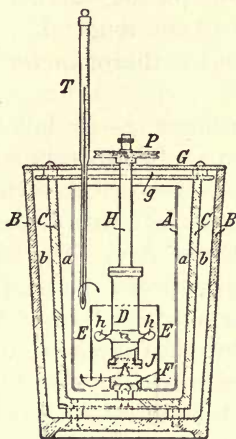

FIG. 27. — Parr Calorimeter.

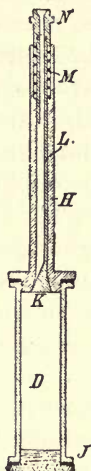

FIG. 28. — Reaction Vessel (for 27).

another similar vessel, *B*. The entire apparatus is closed by the double-cover *G*, made of one piece. Thereby such an excellent heat-insulation is effected that the maximum temperature attained in the reaction remains constant for five minutes, without falling even 0.001° .

The reaction vessel *D* is a heavy, nickel-plated, brass cylinder having a cubic content of about 35 cu. cm.; it is closed at top and bottom with screw plugs and leather gaskets. The lower plug, *I*, rests upon a pivot-step bearing, *F*, connected to the cylinder *E*. The upper plug is provided with a tube *H*, which extends through the cover, *G*, and carries the pulley, *P*. The four blades, *h, h*, are attached to *D*. If the device is set in motion (by means of a Raabe-turbine) at sufficiently high speed (150 rev. per min.) the calorimeter-water moves in the direction of the arrows and a perfectly uniform temperature distribution is obtained in the calorimeter.

From Fig. 28, which shows the reaction vessel (cartridge) on a larger scale it can be seen that the tube *H* contains a small

tube *L* which is open at one side and ends at the bottom in a conical valve *K*. The latter is kept closed by the spiral spring *M* until pressure is applied to *N*.

In the cover, *G*, a hole (8–9 mm. wide) is provided, through which a thermometer divided at least in $\frac{1}{10}$ degrees, but better in $\frac{1}{100}$ degrees, is suspended. The scale of the thermometer goes from 15 to 26 degrees and is 38 to 40 cm. long. It is of importance to have the graduated part of the thermometer absolutely and perfectly cylindrical.

The manipulation of the instrument is as follows: After putting the double-vessel, *CB*, upon a solid table the calorimeter-vessel, *A*, is filled outside of the wooden jacket with exactly 2 liters of water (preferably distilled water), care being taken to keep the outside of *A* and the inside of *C* dry. The temperature of the water should be about 2 degrees below the temperature of the room. *A* is now put into the wooden vessel, *CB*, the reaction-vessel, *D*, is dried perfectly by slightly heating on the sand-bath, the lower cover, *I*, is tightly screwed on and about 10 g. of peroxide of sodium (sifted through 1 mm. mesh) put in. Next 0.5 or 1 g. of the fuel and other substances, to be mentioned later, are introduced into the reaction-vessel, and the cover (whose valve if it should have gotten wet, has to be dried) put on. While pressing *N* upwards, the charge is well shaken, then lightly tapped to settle the mass on the bottom, the valve *K* tried to see if it works easily, *hh* attached and vessel *D* inserted in *A*. The cover, *G*, is now put on, also pulley, *E*, and the cord put over the latter, then the thermometer, *r*, is arranged as shown in the figure. The stirrer is operated (about 3 minutes) until the thermometer reading is perfectly constant, the reading recorded but the motor kept going to the end of the test.

Ignition is effected by means of a glowing piece of iron wire 10 mm. in length and 2.5 mm. in diameter, weighing about 0.4 g. Such a piece can be used frequently until its weight is considerably less than 0.4 g. At a temperature of 700 degrees this wire carries $0.4 \times 0.12 \times 700 = 33.6$ cal., which corresponds to an increase of temperature of 0.016 degrees in the calorimeter. As readings are made with an exactness of 0.005 degree, correction is made by subtracting from the temperature recorded 0.015 degree. The iron wire is seized by means of curved tweezers, heated to red glow in a Bunsen flame, allowed to fall through *N*

into the reaction-vessel; then *N* is pressed down with the tweezers and quickly released, so that the iron falls out of *K* without any gas escaping at *L*. A noise is heard for several seconds, and the temperature rises first rapidly then slowly. After 4 or 5 minutes the maximum is reached, which remains constant for about 5 minutes, then the reading is recorded. The test now being finished, the motor is stopped and the apparatus taken apart. Cylinder, *D*, is put into a dish filled with warm water, wherein its contents are dissolved accompanied by the generation of heat. After neutralizing the solution with hydrochloric acid it is easily noticed whether unburned particles of coal are present, in which case the test is unsuccessful. This, however, happens only with anthracite, when persulphate of potash has not been added. With bituminous coal an addition of tartaric acid is sufficient, while with lignite simply double the amount of coal is used, without the addition of anything. Vessel, *D*, is immediately washed and dried.

The water-value of the calorimeter is 123.5 g. (which should be checked); we have therefore, including the calorimeter-water, 2123.5 g. According to numerous tests (with an increase of temperature = $t' - t$) 73 per cent of the heat generated is from the combustion proper, 27 per cent from the reaction of the products of combustion with Na_2O and Na_2O_2 respectively. If 1 g. of coal has been burned (lignite), $0.73 \times 2123.5 (t' - t) = 1550 (t' - t)$ cal. are generated. We have therefore simply to deduct 0.015 degree (for the heat introduced with the hot iron-wire) from the recorded difference of temperatures $t' - t$ and to multiply the quantity obtained by 1550, to get the thermal-value of 1 g. of coal.

With bituminous coals, of which 0.5 g. is used, the difference of temperature recorded would have to be multiplied by 3100. Previously however 0.85 degree has to be deducted for 0.5 g. of tartaric acid and 0.4 g. of iron at 700 degrees.

With anthracite the following points have to be observed: 1.0 g. of persulphate and 0.4 g. of iron effect an increase of temperature of 0.155 degree; on the other hand, 0.5 g. of tartaric acid and 0.4 g. of iron effect, as we have seen above, an increase of 0.85. Since only one piece of iron is used for ignition we have to deduct the corresponding increase of temperature and we therefore have as correction for 0.5 g. tartaric acid, 1.0 g. of

persulphate and 0.4 g. of iron, $0.85 + 0.155 - 0.015 = 0.99$ degree.

If the sodium peroxide is too moist, the results obtained are too high; in such a case a second test is made with 0.5 g. of tartaric acid and about 7 g. of sodium peroxide. If now the temperature of the calorimeter increases more than 0.85 degree, this has to be considered in the main test by deducting 0.15 degree for every 0.1 degree of observed additional increase. This correction however can be avoided if the peroxide is kept in air-tight cans of 50 g. or 100 g. capacity.

Care must be taken not to throw the mixture of coal and peroxide into water, as otherwise an explosion might take place. This is also the reason why the interior of the valve has to be kept absolutely dry.

Parallel tests made by Lunge and Parr with Parr's calorimeter and Mahler's bomb gave the results shown in Table XXXV.

TABLE XXXV.
TESTS WITH PARR'S CALORIMETER.

Kind of Coal.	Water.	Ash.	Thermal Value.		Differ- ence.	Additions.
			Mah- ler.	Parr.		
Ruhr flaming coal	2.6	7.1	7685	7688 } 7703 } 7695	+ 10	0.600 g. Tartaric acid
Ruhr coal	1.3	6.6	8059	8075	+ 16	0.5 g. Tartaric acid 1.000 g. Persulphate
Anthracite	1.5	6.7	7981	7967 } 8013 } 7990	+ 9	0.600 g. Tartaric acid
Coke	0.6	13.0	6640	6649 } 6726 } 6687	+ 47	0.500 g. Tartaric acid
Welsh Anthracite	2.0	4.2	8049	8044 } 7998 } 8021	- 28	0.600 g. Tartaric acid
English Anthracite	2.4	4.6	8365	8324 } 8327 } 8326	- 39	0.500 g. Tart. acid + 1.000 g. Persulphate
Belgium Braisette	2.4	10.7	7409	7378 } 7409 } 7394	- 15	0.500 g. Tartaric acid
Saar coal	4.9	11.7	6594	6634	+ 40	0.500 g. Tartaric acid
Cardiff coal	2.2	7.2	7872	7936	+ 64	0.500 g. Tartaric acid
Saar coal	3.5	8.4	7146	7161 } 7207 } 7184	+ 38	0.500 g. Tartaric acid
Lignite Briquette	15.17		5037	5084 } 5068 } 5076	+ 39	No addition but 1.000 g. of coal first dried then burned

Test-boilers used for determining the thermal value of fuels on a large scale differ from ordinary boilers; the heat-losses in common boilers are not sufficiently uniform. Therefore an especially constructed calorimeter-boiler has to be used (see Muspratt).

It should be kept in mind in all determinations of heating values that these values vary with the pressure and the temperature at which the combustion takes place. This is of importance, as we can hereby calculate the thermal efficiency of a fuel under different conditions, and in commercial work, where combustion takes place at constant pressure, the figures obtained in the bomb (constant volume) have to be corrected. These variations of the combustion heat are based on the well-known energy principle: the sum of the energy-quantities accumulated in the interior of a system, when the latter changes from one state to another, is exclusively dependent on the initial and final state and independent of the intermediate state. In the special case where the initial and the final state are alike (circular process), this sum is equal to naught.

In the following consideration the heat generated by the system and delivered outside and also the increase of volume of the system is taken as positive.

Relations between combustion heat at constant volume and at constant pressure. The combustion heat at constant pressure is greater than at constant volume. If combustion takes place at 0° C. the difference of the two combustion-heats is, in cal., 0.54 times the contraction of molecular-volume which takes place in the combustion.

If we burn a gas-mixture at constant pressure we obtain a heat quantity Q . At first the volume of the gas is increased by the heat, then it decreases, while cooling off to the starting temperature, to a volume which is smaller than the initial volume. The difference of volumes corresponds to the contraction effected by decrease of the number of molecules present during combustion.

If we allow the combustion to take place in a cylinder (closed at one end, and fitted with an air-tight piston which can move up and down without friction), we can lift this piston after combustion and when the gases have cooled down to the initial temperature, so that the products of combustion occupy the original volume. The work expended thereby is APV .

If, however, the combustion takes place at constant volume, the heat quantity q is generated. According to the above explanations we have

$$q = Q - APV,$$

or since

$$A = \frac{1}{428},$$

we have

$$q = Q - \frac{PV}{428}.$$

If the system contains n mols we have according to Boyle-Gay-Lussac's law,

$$PV = nRT = n \frac{P_0 V_0}{273} T.$$

If we substitute for

$$\begin{aligned} T &= 273, \\ P_0 &= 10,333 \text{ kg. per sq. m.}, \\ V_0 &= 0.02242 \text{ cu. m.}, \end{aligned}$$

we have

$$\begin{aligned} q &= Q - n \frac{P_0 V_0}{273} T A \\ &= Q - n \frac{1033 \times 0.02242 \times 273}{273 \times 428} \\ &= Q - n 0.5411 \text{ cal.} \end{aligned}$$

We can obtain the same value much easier by considering that we have for 1 mol of the gases

$$M (c_p - c_v) = 1.982 \text{ cal.}$$

and that the gas-equation referred to absolute temperature rests on the supposition that the gas laws are correct down to absolute zero and that the gases at this temperature occupy no volume.

We have

$$\begin{aligned} q &= Q - APV \\ &= Q - M (c_p - c_v) T \\ &= Q - \frac{1.982 \times 273}{1000} \\ &= Q - 0.5411 \text{ cal. per mol.} \end{aligned}$$

This equation enables us to transform combustion heats obtained (in the bomb) with constant volume into combustion heat of constant pressure. Per mol. of the substance burned we have:

TABLE XXXVI.

Reaction.	Contraction in Mols.	Combustion Heat at Constant	
		Volume.	Pressure.
$H_2 + O = H_2O$	1.5	68.2	69.0
$CO + O = CO_2$	0.5	67.9	68.2
$\frac{1}{2} (H_2 + CO) + O = \frac{1}{2} (H_2O + CO_2)$	1	68.0	68.5
$CH_2 + 2O_2 = CO_2 + 2H_2O$	2	212.4	213.5
$\frac{1}{2} (2C_2H_2 + 5O_2) = 2CO_2 + H_2O$	1.5	314.9	315.7

All these calculations refer to the case where water is formed in the combustion (upper heat value). For getting the lower heat value the latent heat of evaporation of water (10.8 cal. per mol) has to be deducted.

It follows also from equation $pv = RT$ that wherever 1 mol of a gas at any pressure, p , is generated or disappears, the external work $pv = RT = 1.982 T$ cal. will be consumed or generated. For the average air-temperature of $18^\circ C$. this quantity of work therefore is $1.982 (273 + 18) = 582$ cal. In cases where, as in the bomb, the gases are actually generated or disappear, this phenomenon is taken into account by the combustion heat, which is measured directly. This, however, is not the case in Parr's calorimeter, since here no gaseous oxygen is originally present and since the products of combustion formed disappear again. The determination of carbon is here not affected, the formation of CO_2 taking place without change of volume. It is different with hydrogen, since a contraction takes place during its combustion, but not in Parr's calorimeter. Therefore this calorimeter does not give the combustion heat at constant volume, but at constant pressure, which accounts for the fact that the results found with Parr's calorimeter are higher than the results found with the bomb.

The following law can be derived directly from the energy principle above mentioned:

The heat generated in a direct reaction is the sum of all heat quantities that are generated, provided that from a given

initial state the final state is reached by various consecutive reactions.

This law can be used for calculating reaction heats that cannot be measured directly, for instance, the heat of formation of carbon-monoxide:

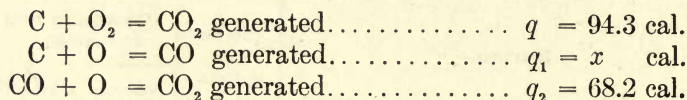

We have according to our law,

$$q = q_1 + q_2.$$

Therefore

$$\begin{aligned} q_1 &= q - q_2 \\ &= 94.3 - 68.2 = 26.1 \text{ cal.} \end{aligned}$$

By this method the heat of formation of all organic compounds is calculated by deducting from their combustion-heats the heat of the elementary components, for instance:

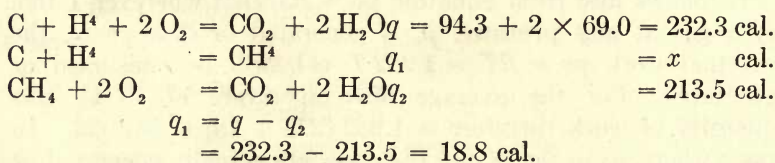

Vice versa we can calculate from the heats of formation of organic compounds (which are found in the thermo-chemical tables) their heats of combustion, for instance:

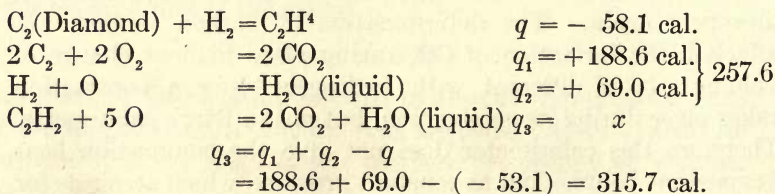

Relations between combustion heat and combustion temperature. The combustion heat changes with the temperature. The change depends on the fact whether the difference of specific heats of the system before and after combustion is positive or negative. We will show this by an example:

We will calculate the combustion heat of hydrogen at 1000° C., supposing that the water formed remains in form of steam. We have then at 15° C.:

$$\text{H}_2 + \text{O} = \text{H}_2\text{O (steam)} \dots q_{15} = +69.0 - 10.8 = +58.2 \text{ cal.}$$

If we burn the hydrogen at 15° C. and heat the steam formed to 1000 degrees, we have:

$$\begin{aligned} q_{15} - \int_{15}^{1000} c \, dt &= 58.2 - 11.0 \\ &= 47.2 \text{ cal.} \end{aligned}$$

If we heat hydrogen and oxygen to 1000 degrees and then burn them at this temperature, we have

$$\begin{aligned} - \int_{15}^{100} (c_1 + c_2) \, dt + q_{1000} &= - (7.5 + 3.7) + q_{1000} \\ &= - 11.2 + q_{1000} \end{aligned}$$

and from this:

$$q_{1000} = q_{15} - \int_{15}^{1000} (c - c_1 - c_2) \, dt = 58.4 \text{ cal.}$$

In this case the difference is small, in others much greater. We have, for instance, for $\text{CO} + \text{O} = \text{CO}_2$,

$$\begin{aligned} q_{15} - \int_{15}^{1000} c \, dt &= 68.2 - 12.4 \\ &= 55.8 \text{ cal.} \end{aligned}$$

$$- \int_{15}^{1000} (c_1 + c_2) \, dt + q_{1000} = q_{1000} - 11.1;$$

and therefore

$$q_{1000} = 66.9 \text{ cal.}$$

If we indicate the heat-capacities of the system in the initial and final state by c_i and c_{ii} we can express this (Kirchhoff's) law by the general formula:

$$q_{t_i} = q_t + (c_i + c_{ii}) (t_i - t).$$

CHAPTER V.

INDIRECT METHODS FOR DETERMINING THE COMBUSTION HEAT.

(a) *Calculation of the thermal value from the elementary analysis.* The fuels used in the industries are mixtures of different, not entirely known, chemical compounds. As these compounds have different thermal values it is evident that the calculation of the thermal value from the elementary analysis does not yield exact results. Furthermore the making of an elementary analysis is more complicated and more tedious than the combustion in a bomb, the difficulty of getting a good average sample being the same in both cases.

For certain fuels, however, by using the proper empirical formula a result can be obtained that is sufficiently good for many practical purposes.

For bituminous coal the following formula is used (Dulong):

$$q = \frac{8080 C + 34600 (H - \frac{1}{8} O)}{100},$$

while for lignite, peat and wood, the formula

$$q = \frac{8080 C + 29633 H_1 - 637 (W + W_1)}{100}$$

is used.

In these equations

C is the per cent of carbon;

H, the per cent of hydrogen;

O, the per cent of oxygen, and

H_1 , the per cent of disposable hydrogen ($H_1 = H - \frac{1}{8} O$).

W means the per cent of chemically combined water ($W = \frac{8}{9} O$).

W_1 means the per cent of hygroscopic water.

NOTE. — Every coal — even dry coal — contains carbon, oxygen and nitrogen. It was formerly thought that the O with a part of H was present as chemically combined water. The excess of H was called “disposable hydrogen.”

8080 means the combustion heat of carbon (Favre and Silbermann).

34,600 means the combustion heat of hydrogen to water.

29,633 means the combustion heat of hydrogen to steam.

637 means the heat of evaporation of water.

If a coal contains combustible sulphur, *i.e.* sulphur in other form than sulphate, some heat in the combustion is also generated by the sulphur, which is taken into consideration by adding to the above formula the product of the percentage sulphur S by $\frac{2500}{100}$ cal.

(b) *Berthier's method for determining the thermal value.*

Berthier's method is based on the determination of the oxygen-quantity required for the complete combustion of the fuel and on Welter's law, the incorrectness of which was proven long ago. This method however is still in use on account of its extraordinary simplicity. Welter supposed that, by burning a certain and constant quantity of oxygen with any other element, always the same amount of heat would be generated. This however is not the case, since 1 kg. of oxygen in combination with the following substances generates the following amounts of heat:

Carbon to carbon dioxide	3030 cal.
Hydrogen to water	4272 cal.
Hydrogen to steam	4192 cal.

As Berthier's calculation is based on the quantity of heat corresponding to the combustion of carbon to carbon dioxide by means of oxygen, it is evident that the results will generally be too low and the lower the more disposable hydrogen is contained in the fuel.

Berthier proceeded as follows: 1 g. (of graphite 0.5 g.) of the finely ground fuel is weighed exactly and mixed with sifted litharge, which is free of metallic particles. The mixture is put into a test-cup (Fig. 29), covered with from 20 to 25 g. of litharge, carefully put into a red-hot muffle-furnace, covered and quickly heated to red-glow; in from three-fourths to one hour the operation is finished and the litharge according to the fuel quantity reduced, by oxidizing the fuel:

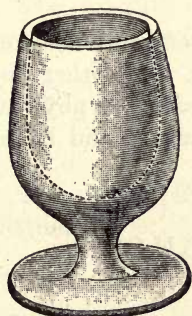
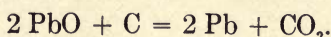

FIG. 29. — Berthier's Coal Tester.



From the weight of the metallic lead obtained, the quantity of oxygen combined with the fuel can be calculated. The test-cup is now removed from the muffle, shaken up several times to combine the small lead-particles, that may be distributed through the litharge, with the main lead mass and allowed to cool. The cup is now broken, the piece of lead brushed clean, and the litharge examined for particles of lead.

In calculating the thermal value, the hydrogen present is not taken into consideration, *i.e.* it is assumed that only the oxygen has combined with carbon. Since 1 kg. carbon reduces about 34 kg. of lead and yields by combustion 8080 cal., the weight of the lead obtained is simply divided by 34 multiplied by 8080 for getting the absolute thermal value of the fuel in question. Sulphur would have to be determined separately and taken into consideration as explained above.

Various modifications of Berthier's test were recommended. Forchhammer suggested the use of oxychloride of lead in place of litharge. Munroe uses instead of the test-cup a gas-pipe provided with a plug at one end, while Strohmeyer oxidizes the fuel by means of cupric oxide, treating the residuum with hydrochloric acid and ferric chloride and determining the ferrous chloride formed by titration.

(c) *Other empirical methods for determining the fuel value.* An important advance is the empirical formula of Dr. Otto Gmelin, based upon a few simple operations, which gives very much better results than Berthier's process.

Gmelin assumed that the coals are mixtures of various chemical compounds, which compounds differ from each other not only chemically, but also physically. He selected such a physical property, the ability of retaining hygroscopic water and based his empirical formula upon this property:

$$q = [100 - (\text{H}_2\text{O} + \text{"ash"})] 80 - C (6 \text{H}_2\text{O}),$$

in which equation H_2O means the hygroscopic water, "ash," the ash-content of the fuel in per cent and C a coefficient which changes with the moisture of the coal and has the following values:

Hygroscopic water below 3 per cent	$C = - 4$
Hygroscopic water between 3 and 4.5 per cent. .	$C = + 6$
Hygroscopic water between 4.5 and 8.0 per cent	$C = + 12$
Hygroscopic water between 8.5 and 12.0 per cent	$C = + 10$
Hygroscopic water between 12 and 20 per cent. .	$C = + 8$
Hygroscopic water between 20 and 28 per cent. .	$C = + 6$
Hygroscopic water over 28 per cent.	$C = + 4$

Seven years later the author tried to utilize more simple properties that would be more independent of accidental circumstances than the moisture, and also be related to the chemical composition and therefore to the combustion-heat of the fuels. He selected the behavior of fuels in dry distillation and the determination of the oxygen required for complete combustion. He proceeds as follows:

About 1 g. of the finely powdered fuel is weighed in a platinum-crucible and — after determining the moisture W by drying at 100° C. — is heated (observing ordinary precautions) until combustible gases are given off. The loss of weight in per cent represents the gas-yield G . The residuum P per cent is now completely burned in the open, inclined crucible whereby the ash content A and the fixed carbon or coke-carbon K is found. The latter however always contains negligible quantities of oxygen, hydrogen and nitrogen.

The quantity of oxygen required S is most conveniently determined with about 5 g. of fuel by Berthier's method.

The quantity of oxygen required for burning the fixed carbon is found by the following equation:

$$S_k = \frac{32}{12} K = \frac{8}{3} K.$$

The oxygen for completely burning the gaseous products of distillation is:

$$S_g = S - S_k = S - \frac{8}{3} K.$$

The combustion heat of the fixed carbon was (as average) empirically determined as 7630 cal. per 1 kg. of carbon, while the combustion heat of the gaseous products of distillation varies

according to the quality of coal and composition of the gases of distillation.

The nature of a fuel is indicated by the ratio (weight) of gaseous products of distillation and fixed carbon $\left(\frac{G}{K}\right)$; and even more so by the ratio of the oxygen required for the volatile matter to the oxygen required for the fixed carbon $\left(\frac{S_g}{S_k}\right)$. The latter ratio is used empirically for determining the thermal-value of a fuel by means of the equation:

$$q = 76.30 K + C \frac{S_g}{100}$$

wherein C is a coefficient, the value of which depends on the quality of the fuel (wood, peat, lignite, coal) and the ratio $\frac{S_g}{S_k}$.

TABLE XXXVII.
RATIO OF S_g TO S_k .

$\frac{S_g}{S_k}$	Values of C for		
	Wood and Peat.	Lignite.	Bitum. Coal.
0.25		5500	5600
0.50	4930	4300	3500
1.00	4830	3420	3250
1.50	4750	3350	3225
2.00	4660	3350	3210
2.50	4570	3360	3200
3.00	4470	3370	3180
3.50	4360		3170
4.00	4255	3500	3150
4.50	4150		3140
5.00	4045	3700	3130
5.50	3940		3120
6.00	3830	3950	3100
6.50			3080
7.00			3070
7.50			3060
8.00			3050

In order to make the formula independent of the kind of fuel and to base the calculation of the thermal value entirely upon the content of moisture, ash, gas, fixed carbon and oxygen required for combustion, the different fuels were divided into

four groups according to their ability to give off gas when dry and free of ash and the value of C calculated for each of the groups according to the different values of $\frac{S_g}{S_k}$. The following table — by means of which the thermal value can be determined without any knowledge of the quality of the fuel — is easily understood.

TABLE XXXVIII.
DATA FOR DETERMINING THERMAL VALUES.

GROUP	I	II	III	IV
Gas given off by the Fuel (dry and free of ash).	0 — 33%	33 — 47.5%	47.5 — 75%	75 — 100%
$\frac{S_g}{S_k}$	Values of the Coefficient C .			
0.10	4900			
0.15	4550	5100		
0.20	4230	4800		
0.25	3960	4500	5250	
0.30	3730	4220	4900	
0.35	3540	4010	4600	
0.40	3380	3850	4350	
0.45	3250	3710	4170	
0.50	3150	3600	4020	
0.54	3086	3512	3932	
0.55	3070	3490	3910	
0.60	3000	3400	3820	
0.70	2900	3280	3690	5050
0.80	2850	3210	3600	4815
0.90	2850	3166	3558	4619
1.00	2850	3130	3550	4480
1.5		2955	3550	4230
2.0			3550	4170
2.5				4120
3.0				4070
3.5				4020
4.0				3970
4.5				3920
5.0				3870
5.5				3820
6.0				3770

The following empirical formulas have since been proposed:
By G. Arth:

$$q = \frac{34,500 (H - \frac{1}{8} O) + 8080 C + 2162 S}{100}$$

By E. Goutal (a modification of Jüptner's formula):

$$q = 8150 C + AM.$$

M is the quantity of volatile matter, A a coefficient the value of which is:

Volatile substances = 2 to 15 per cent. . . . $A = 13,000$

Volatile substances = 15 to 30 per cent. . . . $A = 10,000$

Volatile substances = 30 to 35 per cent. . . . $A = 9500$

Volatile substances = 35 to 40 per cent. . . . $A = 9000$

The international union of the steam-boiler-inspection societies has adopted the following formula:

$$q = \left[8000 C + 2900 \left(H - \frac{O}{8} \right) + 2500 S - 600 W \right] \frac{1}{100},$$

in which W means the quantity of hygroscopic water. The differences against direct calorimetric determinations are (L. C. Wolff):

For bituminous coal ± 2 per cent

For lignite ± 5 per cent

For peat ± 8 per cent

For cellulose $- 7.9$ per cent

For wood ± 12 per cent

By D. Mendeléeff: $q = 81 C + 300 H - 26 (O - S)$.

D. de Paepe has substituted for the value M in Goutal's formula the expression $\frac{100 M}{M + G}$.

SUGGESTIONS FOR LESSONS.

Practice in handling various combustion-calorimeters; determination of water-value and error-limit.

Comparative determination of the combustion heat by different methods.

Calculation of combustion heat at constant pressure from the combustion heat at constant volume and *vice versa*.

Calculation of combustion heats for given combustion temperatures.

CHAPTER VI.

INCOMPLETE COMBUSTION.

THE complete combustion of the fuels used in the industries yields carbon dioxide and water. The chemical composition of the fuel being known, the quantity of oxygen theoretically required for complete combustion is easily calculated. This quantity is called the *theoretical quantity of oxygen* necessary for complete combustion. The average composition of dry air, free of carbon dioxide, being

Oxygen.....	21 per cent vol.	23 per cent weight
Nitrogen.....	79 per cent vol.	77 per cent weight

it is a simple matter to calculate the *theoretical quantity of air* required for complete combustion.

(In many cases it is sufficient to calculate approximately and to assume the composition of air: 20 per cent vol. O and 80 per cent vol. N.) The CO₂ content of the air varies from 0.04 to 0.06 per cent. In densely inhabited buildings it can go as high as 0.5 and even 0.9 per cent vol. The quantity of moisture in the air varies considerably. Air saturated with moisture contains per 1 cu.m.

Degrees C	g. H ₂ O.	Degrees C.	g. H ₂ O.
-10	2.284	+25	22.848
0	4.871	+30	30.095
+5	6.795	+35	39.252
+10	9.362	+40	50.700
+15	12.746	+100	588.730
+20	17.157

The moisture of the air is generally below saturation and above $\frac{1}{10}$ the quantity required for saturation.

In heating tests the moisture of the air has to be determined by means of a hygrometer or psychrometer.

In practice, however, this theoretical quantity of air is not sufficient for complete combustion and therefore an excess of air has to be used.

The reason for this is the difficult and incomplete mixture of the gases to be burned with the combustion air and the occurrence of incomplete reactions.

The incomplete combustion can therefore furnish various products, as follows:

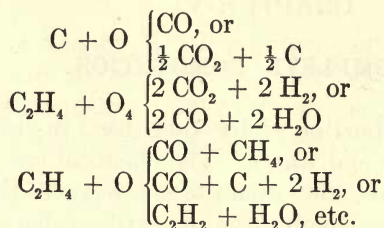

The number of different reactions that can take place simultaneously and in parallel is frequently very great. The number of reactions and the quantity of products depend on the prevailing conditions.

In all these cases we speak of a chemical equilibrium which depends on the so-called equilibrium-conditions. Such conditions are: Temperature, pressure, electric state and the mutual relation of the elementary components present, *i.e.* the concentration. By a change of the conditions, the state of equilibrium is changed as follows (Henry Le Chatelier):

Any change in an equilibrium factor causes a change in the system which is directly opposite to the change in the factor.

This law is best explained by an example:

1. Any increase of temperature causes a change, which tends to decrease the temperature of the system and *vice versa*.
Example:

(a) Dissociation:

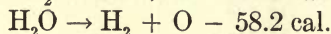
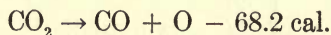

In both reactions heat is absorbed and therefore both are caused or facilitated by increase of temperature.

The reaction

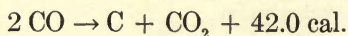

in which heat is liberated, is facilitated by decrease of temperature. Carbon monoxide is therefore more stable at high

than at low temperatures. In the presence of platinum, iron or especially nickel in fine, spongy form this reaction takes place completely at about 300° C.

(b) Incomplete reactions:

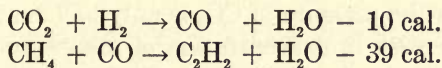

In both reactions absorption of heat takes place; they are therefore caused and facilitated by increase of temperature. At low temperature more $\text{CO}_2 + \text{H}_2$, or $\text{CH}_4 + \text{CO}$; at high temperature more $\text{CO} + \text{H}_2\text{O}$ or $\text{C}_2\text{H}_2 + \text{H}_2\text{O}$, will be present.

The reaction

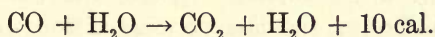

will naturally be facilitated by lowering the temperature.

2. Any increase of outside pressure causes a change of equilibrium, by which the pressure is decreased and *vice versa*. Examples:

(a) Dissociation:

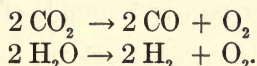

By the dissociation of CO_2 or H_2O the volume, or (at constant volume) the pressure is increased 50 per cent. The dissociation will therefore increase with decreasing pressure and decrease with increasing pressure.

(b) Incomplete reactions:

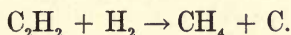

The volume of solid carbon, which is exceedingly small, need not be considered. The volume, however (or at constant volume the pressure), of the CH_4 formed is only half of the volume of the original mixture of C_2H_2 and H_2 . The reaction is therefore facilitated by increasing the pressure. This is proven by explosion in closed vessels, whereby the quantity of CH_4 and C increases with the pressure.

The equilibrium

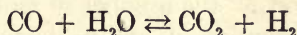

is (if the water is in form of steam) independent of the pressure, as we have on both sides the same volume and therefore also the same pressure.

The reaction

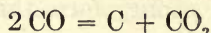

is decreased by decreasing the pressure because the volume and therefore also the pressure of CO_2 is only half that of 2CO .

3. Any increase in concentration of a substance in a system causes a change in the state of equilibrium, in which a certain quantity of this substance is removed and *vice versa* (mass-action). The quantitative expression for the relations between chemical equilibrium and equilibrium-conditions is different if the equilibrium at a certain temperature or the equilibrium at any temperature is considered. In the first case, *i.e.* for the isothermic equilibrium, the law of mass-action; in the second, general case, van't Hoff's or Le Chatelier's equation has to be applied.

For gas-mixtures the latter equation is preferable as the numerical concentration results directly from the volumetric composition of the gases.

We want to consider now an example of great importance in the industries.

DISSOCIATION OF CARBON DIOXIDE.

At high temperature carbon dioxide is decomposed according to the equation:

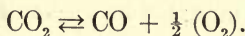

Le Chatelier's equation in general form is:

$$\frac{1}{R} \int \frac{Q_T dT}{T^2} + (N'' - N') l P + \sum n_2 l C_2 - \sum n_1 l C_1 = \text{constant}.$$

In this equation Q_T stands for the total heat of reaction (sum of heat generated and external work performed by the reaction, both expressed in cal.) at the temperature T , P is the pressure of the system, N'' and N' the number of molecules on the right and left side of the equation, n_1 and n_2 the number of molecules, C_1 and C_2 the concentrations of the different substances taking part in the reaction, index 1 meaning the initial system, and 2 the final system.

If we use the common instead of the natural logarithms and if we make $\frac{1}{R} = 500$, we can write our equation:

$$500 \int \frac{Q_T dT}{T^2} + 2.3026 (N'' - N') \log P + 2.3026 \left(\sum n_2 \log C_2 - \sum n_1 \log C_1 \right) = \text{constant.}$$

$$N'' - N' = 1.5 - 1 = 0.5,$$

therefore

$$\sum n_2 \log C_2 - \sum n_1 \log C_1 = \log K = \log \frac{(\bar{C}_{co}) (\bar{C}_{o_2})^{\frac{1}{2}}}{(\bar{C}_{co_2})}$$

If we make the total concentration of the system after the establishment of equilibrium = 1, we have

$$\bar{C}_{co_2} + \bar{C}_{co} + \bar{C}_{o_2} = 1. \quad (1)$$

Assuming that no surplus-oxygen is present, we conclude from the reaction equation:

$$\bar{C}_{o_2} = \frac{1}{2} \bar{C}_{co}. \quad (2)$$

We call x the ratio between the dissociated carbon dioxide, (*i.e.* the carbon monoxide formed) and the quantity of CO_2 that would be present if no dissociation had taken place, *i.e.* $\bar{C}_{co} + \bar{C}_{co_2}$, the coefficient of dissociation, and we have

$$x = \frac{\bar{C}_{co}}{\bar{C}_{co} + \bar{C}_{co_2}}. \quad (3)$$

There can be deduced from (1) and (2) the following equations:

$$\begin{aligned} \bar{C}_{co_2} + \frac{3}{2} \bar{C}_{co} &= 1 \\ \bar{C}_{co_2} &= 1 - \frac{3}{2} \bar{C}_{co} \end{aligned}$$

and therefore

$$x = \frac{\bar{C}_{co}}{1 - \frac{3}{2} \bar{C}_{co} + \bar{C}_{co}} = \frac{\bar{C}_{co}}{1 - \frac{1}{2} \bar{C}_{co}};$$

from this

$$x - \frac{x}{2} \bar{C}_{co} = \bar{C}_{co},$$

or

$$\bar{C}_{co} = \frac{x}{1 + \frac{x}{2}} = \frac{2x}{2+x}, \quad \bar{C}_{o_2} = \frac{x}{2+x}$$

and

$$\bar{C}_{co_2} = 1 - \frac{2x}{2+x} = \frac{2(1-x)}{2+x}.$$

By substituting these three values, we have

$$\log K = \log \frac{(\bar{C}_{co}) (\bar{C}_{o_2})^{\frac{1}{2}}}{(\bar{C}_{co_2})} = \frac{x^{\frac{3}{2}}}{(1-x)(2+x)^{\frac{1}{2}}}.$$

For finding the constant the following observations of Henry Sainte-Claire-Deville are used:

$$P = 1 \text{ at.}$$

$$T = 3000 + 273 = 3273.$$

$$x = 0.40.$$

If we assume (in accordance with Le Chatelier) the total heat of reaction of the reaction $\text{CO} + \text{O} \rightarrow \text{CO}_2$ to be independent of temperature, and taking $Q = 68.2$ cal., we have

$$500 \int \frac{68.2 dT}{T^2} + 1.1513 \log P + 2.3026 \log \frac{x^{\frac{3}{2}}}{(1-x)(2+x)^{\frac{1}{2}}} \\ = \text{Constant};$$

or as for $P = 1$ at., $\log P = 0$.

$$\text{Constant} = -\frac{500 \times 68.2}{3273} + 2.3026 \log \frac{(0.4)^{\frac{3}{2}}}{0.6 (2.4)^{\frac{1}{2}}} = -11.7192;$$

therefore

$$\frac{-34100}{T} + 1.1513 \log P + 2.3026 \log K = -11.7194,$$

or

$$\log K = \left(\frac{34100}{T} - 11.7192 - 1.1513 \log P \right) \frac{1}{2.3026} = \frac{14809}{T} \\ - 5.0895 - 0.5 \log P.$$

From this Le Chatelier has calculated the values of x given in Table XXXIX.

TABLE XXXIX.
COEFFICIENTS OF DISSOCIATION.
(Le Chatelier).

Temperature Degrees C.	Pressure in Atmospheres.					
	0.001	0.01	0.1	1	10	100
1000	0.007	0.003	0.0013	0.0006	0.0003	0.00015
1500	0.07	0.035	0.017	0.008	0.004	0.002
2000	0.40	0.125	0.08	0.04	0.03	0.025
2500	0.81	0.60	0.40	0.19	0.09	0.04
3000	0.94	0.80	0.60	0.40	0.21	0.10
3500	0.96	0.85	0.70	0.53	0.32	0.15
4000	0.97	0.90	0.80	0.63	0.45	0.25

The results of these calculations agree with the observations made at 1500° C. on the density of carbon dioxide.

If we keep in mind that it is the partial pressure of carbon dioxide that is dealt with here, we can make from the above table the following conclusions, which are of importance in practice:

1. *Smelting furnaces.* In smelting furnaces the maximum temperature reached is 2000° C., and the maximum partial pressure of carbon dioxide is about 0.2 at. There is therefore about 5 per cent of the latter dissociated, which decreases the capacity of the furnace to a small extent (maximum $\frac{1}{20}$, but generally much less on account of the excess of air used, which diminishes the dissociation of carbon dioxide).

2. *Illuminating flames.* The luminous flame-zone, in which the separated carbon is burned, seems to have in ordinary flames a temperature of about 2000° C.; in regenerative-burners the temperature is higher. On account of the high percentage of hydrogen in illuminants, the CO_2 — partial — pressure falls below 0.1 at. Therefore the dissociation can go above 10 per cent, the flame-temperature decreasing accordingly. The illuminating power, which increases much faster than the temperature, decreases to a much larger extent, which shows that the dissociation is an important factor in illuminating flames.

3. *Explosives.* Their combustion-temperature is in most cases below 2500°C . and always below 3000°C . As the pressure of carbon dioxide herein goes into thousands of atmospheres, the dissociation does not have to be considered.

On account of the very high pressures, in using the equilibrium equations for explosives, the law of Boyle-Gay-Lussac ($PV = nRT$) must not be used; it is necessary to introduce into the equation a constant b :

$$P(V - b) = nRT.$$

Similar conditions prevail in the dissociation of water. As we have seen above, we have (if no excess of oxygen is present):

$$\bar{C}_{co} = \frac{2x}{2+x}, \text{ quantity of oxygen} = \frac{x}{2+x}$$

$$\bar{C}_{o_2} = \frac{x}{2+x} = \frac{x}{2+x}$$

and

$$\bar{C}_{co_2} = \frac{2(1-x)}{2+x} = \frac{2(1-x)}{2+x}$$

$$\text{Sum} = \frac{2}{2+x}$$

If we have $(n + 1)$ times the quantity of oxygen, the equation for the reaction reads as follows:

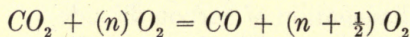

and we have, after the equilibrium has been established,

x' mols CO

$(1 - x')$ mols CO_2

$(\frac{x'}{2} + n)$ mols O_2

$$\Sigma = 1 + \frac{x}{2} + n \text{ mols}$$

and therefore

$$\bar{C}_{co} = \frac{x'}{1 + \frac{x'}{2} + n} = \frac{2x'}{2 + x' + 2n}$$

$$\bar{C}_{o_2} = \frac{\frac{x'}{2} + n}{1 + \frac{x'}{2} + n} = \frac{x' + 2n}{2 + x' + 2n}$$

$$\bar{C}_{co_2} = \frac{1 - x'}{1 + \frac{x'}{2} + n} = \frac{2(1 - x')}{2 + x' + 2n}$$

Therefore

$$\begin{aligned} K &= \frac{(\bar{C}_{co}) (\bar{C}_{o_2})^{\frac{1}{2}}}{(\bar{C}_{co_2})} = \frac{2x'}{2 + x' + 2n} \frac{\left(\frac{x' + 2n}{2 + x' + 2n}\right)^{\frac{1}{2}}}{\frac{2(1 - x')}{2 + x' + 2n}} \\ &= \frac{x' \left(\frac{x' + 2n}{2 + x' + 2n}\right)^{\frac{1}{2}}}{1 - x'} = \frac{x'^{\frac{3}{2}} + x' (2n)^{\frac{1}{2}}}{(1 - x') (2 + x' + 2n)^{\frac{1}{2}}} \end{aligned}$$

As K necessarily has the same value as in the former case, we can say:

$$\frac{x^{\frac{3}{2}}}{(1 - x) (2 + x)^{\frac{1}{2}}} = \frac{x'^{\frac{3}{2}} + x' (2n)^{\frac{1}{2}}}{(1 - x') (2 + x' + 2n)^{\frac{1}{2}}}$$

If we had used twice the theoretical amount of oxygen, n would have been equal to one ($n = 1$) and we would have

$$\begin{aligned} \frac{x^{\frac{3}{2}}}{(1 - x) (2 + x)^{\frac{1}{2}}} &= \frac{x'^{\frac{3}{2}} + x' \sqrt{2}}{(1 - x') (2 + x' + 2)^{\frac{1}{2}}} = \frac{x'^{\frac{3}{2}} + x' \sqrt{2}}{(1 - x') (4 + x')^{\frac{1}{2}}} \\ &= \frac{x'^{\frac{3}{2}} + 1.4142 x'}{(1 - x') (4 + x')^{\frac{1}{2}}} \end{aligned}$$

We found (see above) $\dot{x} = 0.05$ for CO_2 at 2000°C . and 0.2 at partial pressure. Substituting this value, we get:

$$\frac{0.05^{\frac{3}{2}}}{0.95 (2.05)^{\frac{1}{2}}} = 0.000092 = \frac{x'^{\frac{3}{2}} + 1.4142 x'}{(1 - x') (4 + x')^{\frac{1}{2}}},$$

an equation from which x' can easily be calculated. We see at a glance that x' is smaller than x .

CHAPTER VII.

COMBUSTION-TEMPERATURE.

THE maximum temperature that a fuel could produce if burned completely, without any loss of heat, with the theoretical quantity of air, we call pyrometric heating-effect. It is generally calculated from the equation:

$$\pi = \frac{q}{\Sigma cp}$$

wherein q stands for the quantity of heat generated by combustion, and c and p for the specific heat and the quantity of components contained in the products of combustion respectively. This temperature however can never be attained in practice.

The temperatures of industrial fires and fire-places depend on:

1. The quantity of heat furnished by the fuel, which consists of
 - (a) The heat of combustion proper and
 - (b) The heat previously stored, *i.e.* the heat-content of the substances used.
2. The heat carried away by the products of combustion which may be latent (for instance, CO leaving a blast-furnace).
3. The heat lost by radiation.
4. The heat generated or absorbed by the substances to be treated.
5. The quantity of heat used for forming and expanding the gases generated in the fire.

There is a relation between all these quantities, which can be deduced from the principle of conservation of energy.

Proceeding from the fuel, air and substances to be worked, in the first stage, the sum of all heat-quantities introduced into or generated in the fire, is independent of the order in which the transformations take place, depending only on the first and last stage.

We therefore can say that the quantity of heat introduced into the furnace is equal to the quantity taken out of the furnace.

The heat introduced into or generated in the furnace equals the heat taken from the furnace.

These quantities of heat consist of :

1. Heat introduced into the furnace by fuel, air and substances to be worked (by their own temperature).
2. Heat of combustion.
3. Heat of reaction of the substances to be worked.
4. Heat content of the combustion gases.
5. Heat content of the finished products.
6. Loss of heat by radiation.

Since the absolute heat-content of the substances as they enter or as they leave the furnace cannot be determined, we have to be satisfied with a relative determination generally referred to a certain normal condition, which serves as a base for the calculations. As such the temperature of melting ice is generally used.

Let us imagine an ideal furnace which perfectly insulates the heat and in which no working products are present. If we introduce into this furnace fuel and air of a certain temperature (say $0^{\circ}\text{C}.$), allow combustion of same and then cool the combustion gases to the initial temperature ($0^{\circ}\text{C}.$), we have the equation:

$$\text{Heat of combustion} = \text{Heat of cooling.}$$

A. The heat of combustion is a known quantity. The heat of cooling is the difference of the heat-content of the combustion products at the temperature at which they leave the furnace and at the starting temperature (here $0^{\circ}\text{C}.$), to which we imagine them cooled again in the end. In our ideal furnace, the heats of combustion and of cooling are equal. The products of combustion leave the furnace at the combustion temperature, which, as we will see, is easily calculated.

The heat content is equal to the weight of the combustion products multiplied by their specific heat and their temperature. If we use the absolute temperature, we obtain the total heat content; if we use the temperature in centigrade we obtain the heat-quantity, by which the substance in question is richer than at $0^{\circ}\text{C}.$

In calculating the pyrometric heating effect, formerly the specific heat was taken as constant, *i.e.* independent of temperature. The following are the figures used:

TABLE XL.
SPECIFIC HEAT OF GASES AND VAPORS AT CONSTANT PRESSURE
(Referred to Unit Weight.)

Name.	Interval of Temperature. Degrees.	Specific Heat.	Observer.
Air	0—100	0.23741	Régnauld
Air	0—200	0.23751	"
Oxygen	13—207	0.21751	"
Nitrogen	0—200	0.2438	"
Hydrogen	12—198	3.4090	"
Carbon monoxide	23— 99	0.2425	Wiedemann
Carbon monoxide	26—198	0.2426	"
Carbon dioxide	15—100	0.20246	Régnauld
Carbon dioxide	11—214	0.21692	"
Water Vapor	128—217	0.48051	"
Methane	18—208	0.59295	"
Ethylene	24—100	0.3880	Wiedemann

By means of these figures the temperature of combustion of carbon in pure oxygen is calculated as follows:

$$t = \frac{8080}{3.667 \times 0.217} = 10201^{\circ} \text{C.}^*$$

The combustion of coal in the theoretical amount of air should give:

$$t = \frac{8080}{3.667 \times 0.217 + 8.929 \times 0.244} = 2719^{\circ} \text{C.}^{\dagger}$$

while the combustion of carbon with double the volume of air would yield ‡

$$t = \frac{8080}{3.667 \times 0.217 + 8.929 \times 0.244 + 11.596 \times 0.238}$$

$$= \frac{8080}{0.792 + 2.179 + 2.760} = 1410^{\circ} \text{C.}$$

* By the combustion of 1 kg. carbon to CO₂ 8080 cal. are generated; 3.667 kg. CO₂ are thereby formed, having a specific heat of 0.217.

† 8.929 kg. nitrogen are present in the air of combustion besides 2.667 kg. oxygen.

‡ 11.596 kg. is the weight of the surplus air.

TABLE XLI.
COMBUSTION DATA ON VARIOUS UNITS.

Combustion of	Combustion Heat in Cal.	Combustion Temperature in Degrees C.		
		With Pure Oxygen.	With the necessary air Volume.	With double the air Volume.
	Of 1 unit (weight)	Degrees	Degrees	Degrees
Hydrogen to steam	28780	6670	2665
Carbon (amorphous) to carbon dioxide.....	8080	10201	2719	1410
Carbon (amorphous) to carbon monoxide.....	2400	1400
Wood dried at 120°.....	3600	2500	1300
Wood ordinary with 20 per cent hygroscopic water.....	2750	1900	1100
Coke.....	6860	2400	1340
.....	Of 1 Liter
Illuminating gas.....	6.0	7500	2530
.....	Of 1 Mol.
Methane CH ₄ to CO ₂ and H ₂ O....	191930	7160	2440
Ethylene C ₂ H ₄ to CO ₂ and H ₂ O..	313200	8620	2750
Carbon monoxide CO to CO ₂	68370	7180	3040
Water gas CO + H ₂ to CO ₂ + H ₂ O	125930	6940	2860
Benzole C ₆ H ₆ to CO ₂ and H ₂ O....	773400	2790

If the combustion of fuel and air takes place at any other temperature than 0 degrees, proper allowances must be made. If we had to burn, for instance, 1 kg. of hydrogen of 50° C. with exactly the theoretical amount of dry air of 20° C., the quantity of heat available after combustion is figured as follows:

1 kg. of hydrogen of 50° C. contains 1 × 3.409		
× 50.....	=	170.45 cal.
8 kg. of oxygen of 20° C. contain 8 × 0.217		
× 20.....	=	34.88 cal.
26.64 kg. of nitrogen (which are present in the combustion-air besides the oxygen) of 20 degrees contain 26.64 × 0.244 × 20..	=	65.00 cal.
Sum of the heat supplied before combustion..	=	270.33 cal.
The combustion of 1 kg. of hydrogen to steam yields.....		28,780.00 cal.
Heat quantity available after combustion....	=	29,050.33 cal.

On the other hand the heat capacity of the combustion products is:

Steam (1 + 8) × 0.4805.....	=	4.325 cal.
Nitrogen 26.64 × 0.244.....	=	6.500 cal.
Total.....		10.825 cal.

The temperature of combustion therefore is:

$$t = \frac{29,050.33}{10.825} = 2683^{\circ} \text{C.}$$

If the temperature of hydrogen and air before combustion had been 0° C., the temperature of combustion (according to Table XLI) would have been 2665 degrees. The heating of the hydrogen to 50 degrees and of the air to 20 degrees therefore increases the temperature of combustion by 2683 – 2665 = 18° C.

The results of these methods of calculation are too high, as the specific heat of substances increases considerably with the temperature. The law governing the relations of specific heat and temperature (for gases) can be expressed according to Le Chatelier by one of the general equations

$$C_p = 6.5 + aT$$

or

$$C_v = 4.5 + aT.$$

C_p and C_v stand for the average specific heat of 1 gram-molecule at constant pressure or constant volume respectively, T is the absolute temperature, a has the following values for different gases:

for 2 atomic gases (H ₂ , N ₂ , O ₂ , CO).....	a = 0.0006
for CO ₂	a = 0.0037
for H ₂ O.....	a = 0.0029
for C ₂ H ₄	a = 0.0068

The total heat content of a gas at the temperature $T = C_p \times T$ or $C_v \times T$ and the difference of the heat content of a gas between T and T_0 is $C_p (T - T_0)$ and $C_v (T - T_0)$ respectively.

For simplifying the calculation the following table gives the values of $C_p (T - T_0)$, also the difference $(C_p - C_v) (T - T_0) = A \times P (V - V_0) = nAR (T - T_0)$, i.e. the external work according to H. Le Chatelier.

TABLE XLII.

DATA ON EXTERNAL WORK.

Temperature ° C.	0	200	400	600	800	1000	1200	1400	1600
CO, N ₂ , O ₂ , H ₂	0	1.4	2.8	4.3	5.8	7.4	9.0	10.7	12.5
H ₂ O.....	0	1.8	3.7	6.0	8.2	11.0	14.0	17.0	20.3
CO ₂	0	1.9	4.0	6.4	9.0	12.4	15.5	19.2	23.1
Work									
AR(T - T ₀).....	0	0.4	0.8	1.2	1.6	2.0	2.4	2.8	3.2

Temperature ° C.	1800	2000	2200	2400	2600	2800	3000
CO, N ₂ , O ₂ , H ₂	14.2	16.0	17.3	19.1	21.0	22.9	24.8
H ₂ O.....	24.0	28.3	32.5	36.8	41.5	46.4	51.3
CO ₂	27.3	32.0	38.2	43.7	49.6	55.4	61.7
Work							
AR(T - T ₀).....	3.6	4.0	4.4	4.8	5.2	5.6	6.0

EXAMPLE: Calculation of the combustion heat of hydrogen in air. Pure dry air contains in 100 mols.

$$20.8 O_2 + 79.2 N_2, \text{ or about}$$

$$20 O_2 + 80 N_2, \text{ or about 4 mols. } N \text{ for every mol. } O.$$

The combustion of hydrogen with the theoretical amount of air therefore corresponds to the equation:

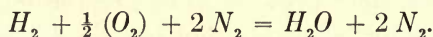

In this equation we have at constant pressure a combustion heat of 58.2 cal. = 58,200 cal. for every mol. of burned hydrogen. The products of combustion consist of 1 mol. steam (H₂O) and 1 mol. nitrogen. Since the combustion heat is equal to the cooling heat, we have:

$$58,200 = 6.5 (T - T_0) + 0.0029 (T^2 - T_0^2) + 2 [6.5 (T - T_0) + 0.0006 (T^2 - T_0^2)] = 19.5 (T - T_0) + 0.0041 (T^2 - T_0^2).$$

If $T_0 = 0^\circ \text{C.}$ and x the temperature (in $^\circ \text{C.}$) to be found, we have

$$T_0 = 273 \quad \text{and} \quad T = 273 + x \quad \text{and} \\ 58,200 = 19.5 x + 0.0041 (546 x + x^2).$$

This is a quadratic equation the solution of which is not at all difficult, but most conveniently obtained by graphical construction. We know that the combustion-temperature is in the neighborhood of 2000° C. Calculating the cooling heats for temperatures in this neighborhood we have, using Table XLI:

	1800°	2000° C.	2200° C.	2400° C.
H ₂ O.....	24.0	28.3	32.5	36.8
2N ₂	28.4	32.0	34.6	38.2
Total.....	52.4	60.3	67.1	75.0

The combustion temperature in question therefore must be between 1800 and 2000° C. By taking the cooling-heats as ordinates and the temperatures as abscissas we obtain the curve shown in Fig. 30. By marking on the ordinate-axis the heat-

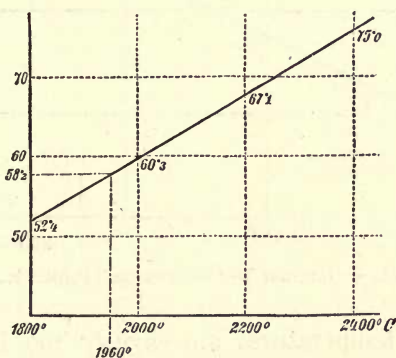

FIG. 30. — Diagram for Combustion Temperatures.

generation (58.2 cal.) drawing from here a horizontal line to its intersection with the curve, and a vertical line through the intersection point, we see that the vertical line intersects the axis of temperature at a point corresponding to the required combustion-temperature (1960° C.). An analogous calculation is applied if the combustion takes place at constant volume (for instance, in Mahler's bomb). The combustion heat at constant volume (taking the water as steam) is 58 calories. The heat

necessary for heating is obtained by deducting the external work $3AR(T - T_0)$:

	1800°	2000°	2200°	2400°
Heat required at constant pressure	52.4	60.3	67.1	75.0
External work.....	10.8	12.0	13.2	14.4
Difference.....	41.6	48.3	53.9	60.6

From Fig. 31 we see that the combustion-temperature is 2320° C. In this calculation the dissociation is not considered; therefore

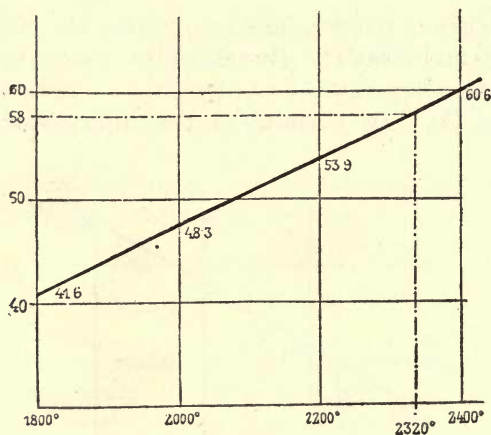

FIG. 31. — Diagram for Combustion Temperatures.

the calculated temperatures are slightly too high. The dissociation however can be taken into consideration by inserting in the temperature equation the coefficient of dissociation as a function of the temperature. Generally, however, a different method is pursued.

As an example we will discuss the combustion of carbon monoxide. Calculating the combustion-temperature without considering the dissociation, we find as the result 2100° C. We know from the preceding chapter that the coefficient of dissociation of carbon dioxide at this temperature and at a partial pressure of 0.20 atm. is 0.06. The heat-generation resulting from combustion therefore is $68(1 - 0.06) = 64$ cal.

In calculating the cooling-heat of the combustion-products we have to take 0.06 less CO_2 (the amount dissociated at this temperature), and we have to add $0.06 \text{ CO} + 0.03 \text{ O}_2$, whereby the heat required for heating is decreased by

$$0.06 (33.8 - 1.5 \times 16.6) = 0.6 \times 8.9 = 5.34 \text{ cal.}$$

The heat of combustion is therefore 2050 instead of 2100° C.

Analogous calculations show the following values for the combustion-temperature of different gases with air containing 20 per cent of oxygen at an initial temperature of 0° C., without considering the dissociation:

TABLE XLIII.

COMBUSTION-TEMPERATURE OF VARIOUS GASES.

	At Constant	
	Pressure.	Volume.
H_2	1960° C	2320° C
CO	2100° C	2430° C
$\frac{1}{2} (\text{CO} + \text{H}_2)$	2040° C	2370° C
CH_4 to $\text{CO}_2 + 2\text{H}_2\text{O}$	1850° C	2150° C
CH_4 to $\text{CO} + 2\text{H}_2\text{O}$	1525° C	1860° C

By comparing these with the previously calculated temperatures of combustion (which were obtained by assuming the specific heats to be constant) the excess of the latter can be noted.

COMBUSTION-TEMPERATURE OF SOLID SUBSTANCES.

The same method of calculation can be applied to the combustion of solid substances as carbon, coals, etc. We suppose again the air to contain 20 per cent volume of oxygen. For simplifying the calculation such quantities of the solid fuel are used that the volume of the gases of combustion (reduced to 0° C. and 760 mm. pressure) is 22.42 liters, *i.e.* corresponds to a mol., because the volumetric composition of the combustion gases then shows directly the number of mols of the different gas-constituents present.

We will now consider the combustion heat of amorphous carbon, which differs from that of diamond or graphite.

12 g. diamond yields.....	94.3 cal.
12 g. graphite yields.....	94.8 cal.
12 g. amorph. carbon yields.....	97.6 cal.

According to the equation

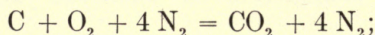

the composition of the combustion gases is:

CO ₂	20 per cent volume
N ₂	80 per cent volume

In order to obtain a molecular volume (22.42 liters) of combustion-gases 0.2 gram-atoms of carbon must be burned, which yields by the combustion:

$$Q = 0.20 \times 97.6 = 19.5 \text{ cal.}$$

The heating of the combustion-products requires:

	2000° C.	2200° C.
For CO ₂	6.40	7.64
For 4N ₂	12.80	13.84
Total.....	19.20	21.48

The combustion-temperature in question therefore is 2026° C. Actually, however, not only CO₂ is formed by the combustion, but also, according to circumstances, either free oxygen (dissociation), or carbon monoxide or steam (from hygroscopic water). Accordingly we get the following results:

COMBUSTION OF AMORPHOUS COAL.

Theoretically, if CO ₂ is formed exclusively...	2026° C.
With 5 per cent oxygen.....	1950° C.
With 5 per cent carbon monoxide.....	1930° C.
Theoretically, with 25 g. of water per 1 kg. carbon.....	1950° C.
Combustion to carbon monoxide.....	1250° C.

COMBUSTION-TEMPERATURE OF A NATURAL COAL.

The combustion-temperature of a natural coal is figured by a similar method. As an example we take bituminous coal of Commentry showing the following composition:

C.....	75.2 per cent
H.....	5.2 per cent
O.....	8.2 per cent
N.....	1.0 per cent
Hygrosc. H ₂ O.....	3.4 per cent
Ash.....	7.0 per cent
Total.....	<u>100.0 per cent</u>

The composition of the combustion gases is calculated as follows:

$$\text{CO}_2 = 752 : 12 = \dots\dots\dots 62.7 \quad (1)$$

$$\left. \begin{array}{l} \text{H}_2\text{O hygroscopic} = 34 : 18 = \dots\dots\dots 1.9 \\ \text{from coal} = 52 : 2 = \dots\dots\dots 26.0 \end{array} \right\} 27.9 \quad (2)$$

N: By the combustion there are formed:

CO ₂ with.....	62.7 O
H ₂ O with.....	13.0 O
Total.....	<u>75.7 O</u>
From the coal.....	2.5 O
Difference.....	<u>73.2 O</u>

This 73.2 O corresponds to

$$\left. \begin{array}{l} 4 \times 73.2 = \dots\dots\dots 292.8 \text{ N} \\ \text{N from coal } 10 : 28 = \dots\dots\dots 0.4 \text{ N} \end{array} \right\} 293.2 \quad (3)$$

Total from (1), (2), (3)..... 383.8 volume.

The volumetric composition of the combustion-gases therefore is:

$$\begin{array}{l} \text{CO}_2 \frac{100 \times 62.7}{383.8} = 16.34 \text{ per cent vol.} \\ \text{H}_2\text{O} \frac{100 \times 27.9}{383.8} = 7.27 \text{ per cent vol.} \\ \text{N} \frac{100 \times 293.2}{383.8} = 76.39 \text{ per cent vol.} \\ \text{Total.....} \quad \underline{100.00} \text{ per cent vol.} \end{array}$$

From this we can figure the heat of the combustion gases:

1800° C.	2000° C.	2200° C.
17.053	19.508	21.820

The combustion heat is

$$Q = 19.888 \text{ cal.}$$

and the combustion-temperature 2034° C.

COMBUSTION-TEMPERATURE OF PRODUCER GAS.

As we shall see later there are frequently used in the industries gaseous fuels, which allow a better utilization of heat. The ideal composition of such a producer gas is:

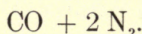

Theoretically, this gas requires for combustion

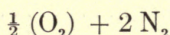

and yields

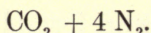

The combustion of $\text{CO} + \frac{1}{2} (\text{O}_2) + 4 \text{N}_2$ gives 68 cal.

If the gas is heated before combustion to 1000° C., $5.5 \times 7.3 = 40$ cal. are required. The total amount of heat, therefore, on which the calculation of the combustion-temperature has to be based is $68 + 40 = 108$ cal.

TABLE XLIV.
HEAT OF THE COMBUSTION PRODUCTS

	2000°.	2200° C.	2400° C.
CO ₂	32.0	38.2	43.7
4N ₂	64.0	69.2	76.4
Total.....	96.0	107.4	120.1

Combustion-temperature = 2220° C.

The same gas gives under different conditions:

Theoretically, cold.....	1500° C.;	cold, 5 per cent O	1210° C.
Gas + air 500°.....	1860° C.;	cold, 5 per cent CO	1320° C.
Gas + air, 1000°.....	2220° C.		

The air used for the production of producer gas always contains varying quantities of water vapor or steam, which is decomposed by coming in contact with glowing coal, so that the gas contains less nitrogen. With an average content of 250 g. of water per kilogram of coal, the gas obtained contains per gram-atom of carbon:

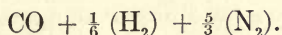

The combustion-temperature of this gas is:

Gas + air: cold.....	1550° C.
Gas + air: 500°.....	1930° C.
Gas + air: 1000°.....	2230° C.

In practice however the composition of producer gas differs from the above, since it always contains some CO₂ and H₂O and also (if bituminous coal or lignite is used) gaseous hydrocarbons. As an example the following analysis of such a gas is given (referred to 1 mol. of gas mixture):

CO.....	0.20 vol.
H ₂	0.10 vol.
CO ₂	0.05 vol.
H ₂ O.....	0.02 vol.
N.....	0.63 vol.
Total.....	1.00 vol.

The combustion of this gas yields:

TABLE XLV.
COMBUSTION OF PRODUCER GAS.

Combustion Products.	Combustion Heat.
CO ₂ 0.25	13.6 cal.
H ₂ O..... 0.12	5.8 cal.
N ₂ 1.23	...
Total..... 1.60	19.4 cal.

The calculation shows the following combustion-temperature:

Gas and air: cold.....	1350° C.
Gas and air: 1000°.....	2150° C.

SUGGESTIONS FOR LESSONS.

Calculation of the combustion-temperature of a fuel of known composition and combustion heat, using different quantities of combustion air, at different temperatures of fuel and air.

Calculation of the combustion-temperature if the composition of the combustion gases (at different temperature of fuel and air) is given, besides the composition and the thermal value of the fuel.

CHAPTER VIII.

FUELS. (IN GENERAL.)

WE call "fuel" any substance which combines with oxygen accompanied by the generation of heat and therefore can be used in practice as a source of power.

Under the term "fuel" in the widest sense of the word we include solids and liquids containing carbon (wood, peat, coal, coke, oil, tar, alcohol, etc.) and gases containing carbon or hydrogen (illuminating gas, natural gas, producer gas, water gas, etc.) and also various other substances, the oxidation of which is used in the industries as a source of heat. Some of the latter substances are:

Sulphur, which is used in southern Italy for smelting crude sulphur (the reason being that no other fuel can be obtained as cheaply).

Sulphides (FeS_2) are used as fuel in the roasting of ore. In the Bessemer process the silicon of the crude iron (acid process) or the phosphorous (basic process) is used as fuel.

TABLE XLVI.

CLASSIFICATION OF FUELS.

Kind of Fuel.	a) Natural.	b) Artificial.
A. Solid	Wood, peat, lignite, bitum, coal, anthracite.	Charcoal, coke, (briquettes).
B. Liquid	Oil	Tar, tar oil, alcohol, etc.
C. Gaseous	Natural gas	Illuminating gas, producer gas, water gas, Dowson gas, blast furnace gas, acetylene, etc.

Lately Goldschmidt has introduced aluminium as a fuel (thermit). A mixture of fine-grained aluminium and certain oxides (Fe_2O_3 , etc.), when ignited, continues to burn and generates considerable heat: $\text{Fe}_2\text{O}_3 + 2\text{Al} = \text{Al}_2\text{O}_3 + 2\text{Fe}$. This process is used for the reduction of metals, preparation of metals and alloys, free of carbon, generation of high temperatures for welding, melting, casting, etc.

In this work we will treat only the first two groups given above, which are commonly called fuels in the true sense of the word.

A. SOLID FUELS.

(a) *Natural Solid Fuels, Wood, Peat, Lignite, Coal and Anthracite.*

All these fuels contain:

1. Ash, which remains after combustion.
2. Hygroscopic water, sometimes called moisture.
3. A substance containing the combustibles and consisting mainly of carbon and variable quantities of hydrogen, oxygen and nitrogen. The composition of this substance free of water and ash is as follows for the different fuels:

TABLE XLVII.
COMPOSITION OF FUELS.

Fuel.	Composition of the Substance (free of Water and Ash).			Thermal Value. Cal.	Coke.	Volatile Matters. %
	C%	H%	O+N%			
Wood	51	6	43	4700	non-coking
Peat	58	6	36	5900	non-coking	70
Lignite	70	5	25	6500	non-coking	50
Bitum. coal:						
lean, long flaming	80—84	5.5	12—10	8200	badly coking ..	35—40
fat, long flaming	84—88	5	9—10	8600	coking	30—35
fat, short flaming	86—90	5—4.5	7—5.5	8700	coking	16—23
lean, short flaming	90—93	4.5—3.5	5.5—4.5	8600	badly coking ..	6—14
Anthracite	95	2	3	8200	non coking	3

The ash content varies from about 5 per cent to 15 per cent. The amount of hygroscopic water depends on the humidity of

the atmosphere, and the nature and porosity of the fuel; it generally increases in direct proportion with the volatile matter. Coke forms an exception as it sometimes contains considerable water, which however is not hygroscopic but was introduced by the manufacturing process (cooling of the hot coke with water).

The coking of fuels by heating is of great practical importance, preventing small-size coal from falling through the grate bars. Small-sized lean coal is troublesome to burn on a grate. On the other hand coking too much may cause trouble, as thereby a considerable amount of coal is prevented from burning up and the grate cannot be properly cleaned.

Some lean fuels have the property of disintegrating in heat and falling through the grate before being burned up.

The natural solid fuels are of great importance for the industries on account of their low cost. They can be classified in

(α) Vegetable fuels: wood.

(β) Fossile fuels: peat, lignite, coal and anthracite.

(b) *Artificial Solid Fuels.*

For certain purposes it is of advantage to use fuels richer in carbon than the ones occurring in nature. This is done by subjecting the natural solid fuels to dry distillation, whereby the following products of decomposition are formed:

1. Gases.
2. Tar.
3. Tar-water.
4. Carbonaceous residuum.

The relative quantity of these substances depends on the nature of the substance from which it originated, and the temperature of distillation. With increasing temperature the quantity of gas is increased, but the content of heavy hydrocarbons and therefore the illuminating power decreased.

The advantages of the coked fuel are:

1. A fuel of higher thermal value:
 - (a) The content of carbon of the coked fuel being higher than that of the raw fuel.
 - (b) The gaseous products of distillation requiring a great amount of heat for their gasification in using crude fuel.

Thereby the cost of transportation per heat unit is decreased.

2. Coked fuel burns without smoke.
3. Coked fuel does not cake or form clinkers.
4. The sulphur content of the raw fuel is decreased by coking.
5. Valuable by-products are furnished by the coking process.

On the other hand we have to consider the following disadvantages of coking.

1. The coking entails a certain expense due to heat, fuel, wages and machinery.
2. Coked fuel never burns with a long flame, which is essential in certain cases.
3. Coking increases the ash content.

According to the raw material used the coked products are called:

- (a) Charcoal.
- (b) Peat coal.
- (c) Coke.
- (d) Briquettes.

CHAPTER IX.

WOOD.

THE industrial importance of wood as fuel is not very great. It is, however, used to a large extent for building and construction purposes which makes a detailed discussion desirable.

According to the trees from which the woods originate they may be classified as:

(a) Leaved woods: maple, birch, beech, oak, alder, ash, linden, poplar, elm, willow, etc.

(b) Coniferous woods: red pine, pine, larch, fir.

TABLE XLVIII.

CLASSIFICATION OF WOODS ACCORDING TO SPECIFIC GRAVITY.

Hard Woods.		Soft Woods.	
Specific Gravity (air dry)	> 0.55	Specific Gravity (air dry)	< 0.55
Specific Gravity (green)	> 0.90	Specific Gravity (green)	< 0.90
Beech	= 0.77	Silver fir	= 0.48
Oak	= 0.71	Red pine	= 0.47
Ash	= 0.67	Fir	= 0.55
Maple	= 0.64	Larch	= 0.47
Elm	= 0.57	Linden	= 0.44
Birch	= 0.55	Willow	= 0.48
Alder	= 0.54	Trembling poplar	= 0.43
		Poplar	= 0.39
		Black poplar	= 0.39

The specific gravity of wood is somewhat variable: it is greater the slower the growth of the tree, *i.e.*, the dryer the soil. Sometimes the following classification is used.

1. Hard woods (leaved woods only): oak, beech, white beech, ash, maple, birch, etc.

2. Soft woods (soft leaved woods): chestnut, linden, trembling poplar, willow, etc.

3. Coniferous woods: fir, silver fir, etc.



The specific gravities given above include the pores of the wood. Excluding the pores these figures are considerably higher (Rumford). See Table XLIX.

TABLE XLIX.
SPECIFIC GRAVITY OF WOOD SUBSTANCE.

Wood.	Specific Gravity.	Wood.	Specific Gravity.
Oak.....	1.5344	Birch.....	1.4848
Beech.....	1.5284	Linden.....	1.4846
Elm.....	1.5186	Fir.....	1.4612
Poplar.....	1.4854	Maple.....	1.4599

The following figures relative to specific gravity of woods will be of interest:

TABLE L.
SPECIFIC GRAVITY OF VARIOUS WOODS.

Kind of Tree.	Brisson.	Hartig.		Werneck.	Winkler.	Muschelbrock.
		Green.	Seasoned.	Well Seasoned.	Well Seasoned.	
Scarlet oak.....		1.0754	0.7075	0.6441	0.663	0.929
Beech.....	0.85	0.9822	0.5907	0.5452	0.560	0.852
Elm.....	0.67	0.9476	0.5474	0.5788	0.518	0.600
Larch.....		0.9250	0.4735		0.441	
Pine.....		0.9121	0.5502	0.4205	0.485	
Maple.....	0.75	0.9036	0.6592	0.5779	0.618	0.755
Ash.....	0.84	0.9036	0.6440	0.6337	0.619	0.734
Birch.....		0.9012	0.5550	0.5699	0.598	
Service.....		0.8993	0.4716		0.552	
Fir.....	0.55	0.8941	0.5910	0.4303	0.493	0.550
Red pine.....		0.8699	0.5749	0.3838	0.434	
Mealy pear.....		0.8633	0.5001		0.549	0.874
Chestnut.....		0.8614	0.4390			
Alder.....	0.80	0.8571	0.3656		0.443	0.800
Linden.....	0.60	0.8170	0.4302	0.3480	0.431	0.604
Black poplar.....		0.7795	0.3931		0.346	0.383
Aspen.....		0.7654	0.4302		0.418	
Italian poplar.....		0.7634	0.3931	0.4402		
Sallow.....		0.7155	0.5289		0.501	
Pomegranate.....	1.35					
Ebony.....	1.33					
Dutch box.....	1.32					
Medlar.....	0.94					
Olive.....	0.92					
French box.....	0.91					
Spanish mulberry.....	0.89					
Spanish yew.....	0.80					

Another classification of woods is based on the following properties:

The youngest wood of a tree trunk is called sap-wood. It contains more sap and is lighter in color than the older wood. In some trees the older wood hardly changes (maple, birch, white beech, etc.); in some the sap-wood is darker and dryer (linden, red pine, fir tree, etc.); in some trees a darker, dryer and stronger wood is formed in the course of time, which is called heart-wood (ebony, walnut, larch, fir, etc.).

The weight of wood piles is of more importance than the specific gravity. The net cubic contents of a wood pile is the volume of wood substance including the pores. Its weight in kilograms is 1000 times the specific gravity of the wood. The gross cubic contents of a pile depends upon the density of the pile and the moisture of the wood. Furthermore, the density depends upon the shape and form of the pieces of wood (cord wood, stove wood and brush wood). The moisture decreases with the length of time the wood is stored, down to from 12 to 13 per cent. The actual contents of the wood pile is the volume of wood substance in a certain volume of wood pile.

TABLE LI.

ACTUAL CONTENT IN PER CENT OF DIFFERENT WOODS.

Kind of Wood.	Mini- mum.	Maxi- mum.	Aver- age.
Cord wood of leaved wood, logwood and billet wood of coniferous trees, strong, smooth and straight..	73	77	75
Cord wood of leaved and coniferous woods, weak, smooth and straight	68	72	70
Cord wood of coniferous woods, strong and weak, knotty and crooked.....			
Stove wood of leaved wood, strong, smooth, straight	63	67	65
Cord wood of leaved wood, strong and weak, knotty and crooked			
Stove wood of leaved and coniferous wood, strong and weak, smooth and knotty, straight and crooked	58	62	60
Brushwood from trunk, coniferous wood.....			
Brushwood from trunk, leaved wood	53	57	55
Brushwood from branches, coniferous wood.....	48	52	50
Brushwood from branches, leaved wood.....	42	48	45
Rootwood (leaved and coniferous tree)			

TABLE LII.
WEIGHTS OF WOOD IN PILES.

(Woods cut in winter.)

Kind of Tree.	Green.				Seasoned.			
	Cordwood.		Stove-wood.	Brush.	Cordwood.		Stove-wood.	Brush.
	Bark.	Heart-wood.			Bark.	Heart-wood.		
	Weight in Kilograms of 1 Solid Cubic Meter.							
Red pine	892	717	881	926	457	445	334	511
Pine	950	690	937	869	554	503	551	516
Larch			929				624	
Silver fir			937				469	
Oak	741	923	968	903	548	669	703	702
Red beech	790	878	955	930	687	734	696	673
Hornbeam			1019	1045			762	780
Birch	978			986	734			712
Linden				781				484
Maple			979				717	
Norway maple	1051	933			741	797		

CHEMICAL COMPOSITION.

Wood is composed chemically of (1) fiber and (2) sap.

The wood fiber consists mainly of cellulose $C_6H_{10}O_5$ (C, 44.44 per cent; H, 6.17 per cent; O, 49.39 per cent). Besides cellulose we find other organic matter, both nitrogenous and non-nitrogenous, which are generally called "incrustating materials." They increase towards the center and cause the dark color.

The analyses given in Table LIII show the variations in the composition of different woods dry and free of ash: (H. Chevandier).

TABLE LIII.
COMPOSITION OF DIFFERENT WOODS.

Kind of Tree.	C Per cent.	H Per cent.	O and N Per cent.
Maple	49.80	6.31	43.89
Oak	50.64	6.03	42.05 1.28
Pine	49.94	6.25	43.81
Willow	51.75	6.19	41.08 0.98

The average composition therefore is:

C.....	49.2
H.....	6.1
O and N.....	44.7

The sap is a solution of various organic (protein, tannic acid, vegetable acids, starch, sugar, essential oils, resins) and inorganic substances in water.

Considering the use of wood as fuel, only the content of resin, water and ash has to be considered.

With increasing content of resin, the thermal value increases.

In order to determine the resin content Hampel treated Austrian woods with 90 per cent alcohol. Table LIV gives the per cents dissolved.

TABLE LIV.
RESIN CONTENT OF WOODS.

Kind of Tree.	Per cent.
<i>Taxus baccata</i> L. (yew).....	7.514
<i>Abies excelsa</i> D. C. (fir).....	2.734
<i>Larix europæa</i> D. C. (larch).....	1.807
<i>Pinus silvestris</i> L. (pine).....	1.744
<i>Acer pseudoplatanus</i> L. (maple).....	1.69
<i>Fraxinus excelsior</i> L. (ash).....	1.47
<i>Fagus sylvaticus</i> L. (red beech).....	1.44
<i>Betula alba</i> L. (birch).....	1.167

The ash content of various woods may be taken from Table LV.

TABLE LV.
ASH CONTENT OF VARIOUS WOODS.

	Fresh Wood.	Old Wood.		Trunk Wood.	Branch Wood.	Brush Wood.
Pine.....	0.12	0.15	Oak.....	1.94	1.49	1.32
Oak.....	0.15	0.11	Beech.....	0.73	1.54	0.72
Pitch pine..	0.15	0.15	Aspen.....	1.49	2.38
Birch.....	0.25	0.30	Willow....	2.94	3.66

The ash content depends largely on the ash content of the soil. The moisture changes with the seasons, is the lowest in winter and the highest in spring. It also changes with the different trees.

Kind of Tree.	H ₂ O Per cent.	English Name.
Carpinus betulus	18.6	Hornbeam
Salix caprea	26.0	Sallow
Acer pseudoplatanus	27.0	Maple
Sorbus aucuparia	28.3	Service
Fraxinus excelsior	28.7	Ash
Betula alba	30.8	Birch
Quercus robur	34.7	Oak
Pinus silvestris	39.7	Pine
Pinus larix	48.6	Larch

TABLE LVI.

MOISTURE IN VARIOUS WOODS.

Kind of Tree.	Water Content.
Hornbeam (<i>Carpinus betulus</i>)	18.6
Sallow (<i>Salix caprea</i>)	26.0
Maple (<i>Acer pseudoplatanus</i>)	27.0
Service tree (<i>Sorbus aucuparia</i>)	28.3
Ash (<i>Fraxinus excelsior</i>)	28.7
Birch (<i>Betula alba</i>)	30.8
Oak (<i>Quercus robur</i>)	34.7
Pine (<i>Pinus silvestris</i> , L.)	39.7
Larch (<i>Pinus larix</i>)	48.6

The researches of Vrolle (Table LVII) show how great are the variations in the ash content, for instance, in the case of the cherry tree.

TABLE LVII.

ASH CONTENT OF VARIOUS PARTS OF A CHERRY TREE.

Part of Tree.	C Per cent.	H Per cent.	O + N Per cent.	Ash Per cent.
Leaves	45.015	6.971	40.910	7.118
Upper point of branch, bark	52.496	7.312	36.637	3.454
Upper point of branch, wood	48.359	6.605	44.730	0.304
Middle part of branch, bark	48.855	6.342	41.121	3.682
Middle part of branch, wood	49.902	6.607	43.356	0.134
Lower part of branch, bark	46.871	5.570	44.656	2.903
Lower part of branch, wood	48.003	6.472	45.170	0.354
Trunk, bark	46.267	5.930	44.755	2.657
Trunk, wood	48.925	6.460	44.319	0.296
Upper part of root, bark	49.085	6.024	48.761	1.129
Upper part of root, wood	49.324	6.286	44.108	0.231
Middle part of root, bark	50.367	6.069	41.920	1.643
Middle part of root, wood	47.399	6.259	46.126	0.223
Lower part of root	45.063	5.036	43.503	5.007

Henneberg's researches show how the ash content depends on the soil. Table LVIII shows the composition of beech wood ash:

TABLE LVIII.
ASH ANALYSES.

Components.	Kind of Soil.		
	Limestone. Per cent.	Gypsum. Per cent.	Sandstone. Per cent.
Carbonate of potash.....	6.7	14.6	{ 4.7
Carbonate of soda.....	11.0		{ 3.2
Sulphate of potash.....	4.4	3.4	23.3
Chloride of sodium.....	0.7	trace	5.0
Soluble salts.....	22.8	18.0	36.2
Carbonate of lime.....	27.4	30.9	21.1
Magnesia.....	17.7	12.2	12.4
Phosphates.....	15.6	9.7	10.9
Silicic acid.....	16.9	28.7	18.4
Insoluble components.....	77.6	81.5	61.0

For metallurgical purposes the quantity of phosphorus in wood is of interest. R. Akerman and Sarnstrom found that:

1. Leaved wood contains from 4 to 5 times as much phosphorus as coniferous trees.

2. The quantity of phosphorus in the same kind of wood varies 100 per cent according to the country of origin.

3. Fir wood cut in winter contains more phosphorus than when cut in spring or summer.

4. The trunk contains the least, branches, twigs and especially the bark contain the most.

5. The phosphorus of sap-wood can to a large extent easily be washed out.

The moisture of wood depends considerably on the season (Schuebler):

Kind of Tree.	Percentage of Water.	
	End of January.	Beginning of April.
Ash.....	28.8	38.6
Maple.....	33.6	40.3
Horse chestnut.....	40.2	47.1
Fir tree.....	52.7	61.6
Fresh ash.....	28-29	38-39
Red pine (root).....	52	61

The moisture varies in the different parts of the trees. It is higher in the outer parts than in the inner parts, higher in the branches than in the trunk. It also depends on the soil and climatic conditions.

Air drying reduces the moisture after two summers to about 20 per cent, in very dry summers to from 15 to 16 per cent.

For drying wood more perfectly higher temperatures have to be applied. Woods exposed for two years to 125° C. and 225° C. lost water as shown in Table LIX. (Violette):

TABLE LIX.
DATA ON THE SEASONING OF WOOD.

Temperature.	100 Parts of Wood give off Water.			
	Oak.	Ash.	Elm.	Walnut.
125° C	15.26	14.78	15.32	15.55
150° C	17.93	16.19	17.02	17.43
175° C	32.13	21.22	36.94	21.00
200° C	35.80	27.51	33.38	41.77
225° C	44.31	33.38	40.56	36.56

At 200° C. dry distillation begins. Wood dried at higher temperature readily absorbs water. Wood (shavings) dried at 136° C. absorbed in 24 hours in winter from 17 to 19 per cent, in summer from 6 to 9 per cent water.

By drying, the volume is decreased; by moistening, increased.

TABLE LX.
THERMAL VALUE OF VARIOUS WOODS (per kg.).

Kind of Wood.	Pb reduced by 1 Part of Wood.	Calories.	Specific Gravity.
Air-dried wood (20% water).....		3600
Dried wood (10% water).....		4100
White beech, air dried.....	12.5	3100	0.770
Oak, air dried.....	14.05	2400—3000	0.708
Maple, air dried.....	14.16	3600	0.645
Pine, air dried.....	13.27	0.550
Willow, air dried.....	13.10	0.487
Linden, air dried.....	14.48	3400—4000	0.439
Birch, air dried.....	14.08	0.627
Fir tree, air dried.....	13.86	0.481

The heat of combustion of cellulose per kilogram is as follows, (if the water formed appears in liquid form) for:

Purified cotton.....	4200 cal.
From paper.....	4188.1 cal.
From ammoniacal solution of cupric oxide.....	4174.1 cal.
Purified with bromine water and ammonia.....	4191.9 cal.
Average.....	4188.5 cal.
For water vapor.....	3591 cal.

Boise has found the evaporating power of different kinds of wood to be as given in Table LXI.

TABLE LXI.
EVAPORATING POWER OF WOOD.

Kind of Tree.	Water.	Ash.		Kilograms of Water transformed into Steam by 1 Kilo-gram of Wood.	
		Unseasoned.	Seasoned.	Unseasoned.	Seasoned.
	Per cent.			Wood.	
Old pine.....	16.1	1.92	2.29	4.18	5.11
Young pine.....	19.3	1.73	2.15	3.62	4.77
Alder.....	14.7	0.95	1.11	3.84	4.67
Birch.....	12.3	1.00	1.14	3.72	4.39
Oak.....	18.7	1.13	1.39	3.54	4.60
Old red beech.....	22.2	1.43	1.84	3.39	4.63
Young red beech.....	14.3	1.39	1.62	3.49	4.25
White beech.....	12.5	2.17	2.48	3.62	4.28

Winkler has found the comparative fuel value of woods, considering the same volume, to be as given in Table LXII.

TABLE LXII.
COMPARATIVE FUEL VALUE OF VARIOUS WOODS (Winkler).

Kind of Wood (dry).	Red Pine = 100.	Red Beech = 100.
Oak.....	169	118
Elm.....	156	109
Maple.....	153	106
Birch.....	152	105
Beech.....	143	100
Fir.....	112	78
Willow.....	110	77
Poplar.....	109	76
Pine.....	106	74
Red pine.....	100	70
Linden.....	92	64

Since wood, when used as fuel, is almost always measured instead of weighed, this table is of considerable importance, also on account of the volume being less affected by moisture than the weight.

If we call best beech wood equal to 100 we get the following scale for the value of woods.

I. Fuel quality = 100: beech, birch, pine rich in resin, mountain pine, acacia.

II. Fuel quality = 95 to 90: maple, elm, ash, larch rich in resin, chestnut, ordinary pine.

III. Fuel quality = 85 to 75: red pine, fir, Siberian stone pine.

IV. Fuel quality = 70: linden.

V. Fuel quality = 65 to 60: alder, poplar, oak, aspen.

VI. Fuel quality = 55 to 50: willow.

These values naturally depend also on the use the wood is to be put to. For quickly raising the temperature, for instance, soft wood, especially coniferous wood is used. For domestic use 1.5 cu. m. of soft wood take the place of 1 cu. m. of hard wood.

The different parts of a tree have a different fuel quality. Taking trunk wood as = 1, we have

Trunk wood.....	0.90 to 0.80
Branch wood.....	0.90 to 0.75
Twig wood	0.85 to 0.80
Root wood.....	0.65 to 0.50
Root wood, rotten.....	0.40
Wind-fallen wood.....	0.85 to 0.50

CHAPTER X.

FOSSIL SOLID FUELS. (IN GENERAL.)

ALL fuels containing carbon are of vegetable origin and differ from each other according to the kind of the plant from which they come and the quality and quantity of the transformation of the vegetable fiber. The course of carbonification is entirely different if the vegetable masses are covered with water, and if the plants are isolated from the atmosphere by layers of clay.

Geologically these fuels can be divided in:

1. Younger fossil coals:

(a) Peat.

(b) Brown coal (lignite).

2. Older fossil coals (bituminous coal and anthracite). These coals are formed by a process called natural carbonification (carbonaceous decomposition), which was studied by the Swiss geologist, A. Balzer.

Balzer states that in this process two kinds of substances have to be dealt with, namely: products of decomposition and residuum of decomposition.

We can obtain some idea of the nature of the products of decomposition from the methane in the mines; the gases in the fresh coal; the changes of fresh coal in the atmosphere (which changes are a continuation of the process of carbonification), and from certain laboratory experiments on the behaviour of wood in an atmosphere of oxygen.

The methane in the coal mines is a real product of decomposition.

The gases held in absorption by coals are of the same nature. Meyer found that 100 g. of coal yield from 17 to 59 cu. cm. of a gas containing carbon dioxide, oxygen, nitrogen, methane, ethane and probably butylene. It is undecided how much of the nitrogen has its source in the vegetable matter and how much in the atmosphere.

Relating to the behavior of wood in an atmosphere of oxygen, Saussure observed that wood shavings enclosed in an oxygen atmosphere transformed the latter into the same volume of carbon dioxide. The same observation was made by Liebig for moist and old wood. Wiesner found that the first stage of decomposition of wood consists in the appearance of gray color, whereby the intercellular substance vanishes and practically pure cellulose remains. Moist lignite absorbs oxygen from the atmosphere and generates carbon dioxide.

Liebig made the conclusion from his experiments, that first of all the hydrogen of the wood is oxidized, while the oxygen of the hydrate water combines with the carbon of the wood to form carbon dioxide. Considering the fact that methane is formed during the transformation of wood into coal, he calculates that cannel coal can be explained as wood fiber less 3 molecules CH_4 , 3 mol. H_2O and 9 mol. CO_2 . Brown coal is oak wood less 2 H_2O and 3 CO_2 , etc.

Relating to the influence of the exclusion of air in the formation of coal, Bischof stated that atmospheric oxygen is not essential and that the coal deposits must have been formed mainly under exclusion of oxygen, water having served as the seal in the sea, on the shores and in meadows. In some cases the water was replaced by sand and clay deposits. The ash content of coals proves this fact. The oxygen which is found dissolved in sea water certainly did not have much effect, since according to Hayes, metals kept at a certain depth in the sea are not oxidized.

As to the chemical expression of the carbonaceous decomposition Balzer says: According to Bischof there are three ways possible for the decomposition to take place according as carbon dioxide and water, carbon dioxide and methane, or carbon dioxide, water and methane are formed. The one of these processes which takes place is determined by the amount of the reacting air, temperature and pressure. When vegetable products during the carbonaceous age were carried by rivers into basins of salt or fresh water, where formation of coal took place, large quantities of methane were formed. If by some geological change the basin becomes dry, the process goes on principally as oxidation. If now a considerable amount of sediment is deposited the formation of coal has to continue, though slowly, without oxygen.

According to Balzer the influence of temperature is as follows: Low temperature decreases the velocity of coal formation. The temperature in the deepest part of the Atlantic Ocean at from 49 to 57 degrees latitude is 2.1°C . In regions where the lowest winter temperature of the air is 4°C ., the deepest layers of water have a constant temperature of from 5 to 6°C . The carbonification, which is a "voluntary" decomposition of organic substances, is certainly an exceedingly slow reaction at this temperature, and must have been much slower yet in the glacial age.

The influence of pressure is as follows: It is uncertain whether an increase in pressure increases or decreases the velocity of carbonification and the optimum of pressure is also unknown. We cannot make any deductions from the fact that CaCO_3 remains undecomposed at high pressure since in organic reactions with closed glass-tubes the generation of gas and chemical reaction ordinarily takes place at high pressure and high temperature. Paraffin is decomposed by high pressure and high temperature in hydrocarbons of the methane and ethylene series. In such cases the reactions taking place change with changes in temperature and pressure.

A certain semi-soft condition of the wet mass can be considered as advantageous for the reaction.

Valuable information relating to the changes of coals in the atmosphere at ordinary and higher temperature are given by Richter.

It is known that coal absorbs oxygen of the air. Charcoal absorbs nine times its volume of oxygen. Coals absorb gases as readily as a dry sponge absorbs water. If coal is saturated with one gas, some other gas can be absorbed in addition. With the assistance of moisture the oxygen is compressed in the coal, ozonised and thereby becomes chemically active, causing an increase of temperature. (Self-ignition of powdered coal.)

Richter observed that the capacity of coal for absorbing oxygen increases up to 200 degrees, at which temperature the absorption stops. Hydrogen and oxygen are absorbed in the proportion 2 : 16. On account of oxidation in the air deterioration of coal takes place, shape and color are changed, thermal value and coking capacity decreased.

Since only a part of the hydrogen of the coal is oxidized the

hydrogen must be present in different combinations, which is important for the theory of the constitution of coals.

Considering the residuum of decomposition Balzer mentions the constitution of the wood-substance. The coals are chemical derivatives of cellulose, consequently of the wood-substance. The constitution of these substances and their relations to each other are not positively known. It seems, however, that cellulose does not occur in a free state in wood. From fir wood we can isolate by extraction with ordinary solvents a yellowish-white substance having the formula $C_{30}H_{46}O_{21}$, which is only slightly soluble in ammoniacal cupric oxide, being thereby essentially different from cellulose. By boiling with hydrochloric acid, glucose and lignose ($C_{18}H_{26}O_{11}$) was formed. The latter, which is also insoluble in ammoniacal cupric oxide, is transformed by boiling with nitric acid, into cellulose and certain substances of the aromatic series. From these reactions we can conclude that fir wood contains, besides the cellulose-group, a sugar-forming and an aromatic group, so that its composition is much more complicated than that of cellulose.

What is the relation of wood substance to coal? It is known that in the carbonaceous decomposition the relative quantity of carbon and ash increases and the quantity of hydrogen, oxygen and nitrogen decreases. The different qualities of coal from peat to anthracite show different stages of this process, but the formation of one kind of coal from the other cannot be expressed by a chemical equation.

Balzer makes the following hypotheses relative to the constitution of coals:

1. The coals are mixtures of complicated carbon compounds (organic substances),
2. Which form a continuous (or possibly homogeneous) series.
3. The carbon ring of these compounds is complicated and somewhat analogous to aromatic compounds.

Balzer states that besides the carbonaceous decomposition proper a destructive distillation can take place, for instance, by contact with hot bodies or fires. In Hessen, Germany, molten basalt has in this way transformed lignite into anthracite coal, the anthracite deposit changing gradually into the lignite deposit. In some places eruptive porphyry has transformed lignite at the contact points into coke.

Supposing an increase of temperature towards the center of the earth, we can assume 100° C. at a depth of 2600 m. Products of distillation formed in these regions can condense in the upper regions, the lower layers forming the retort, the upper the condensing chamber. Balzer believes that this reaction takes place with petroleum, which is "distilled" from coal deposits, bituminous slates, etc.

Since petroleum occurs in silurian, devonian and tertiary formations it is apparent that the place of "occurrence" is different from the place of "formation," which can be explained by distillation, above referred to.

Supposing that the carbon in the coals is present as such, we consider the coal deposits as end products, while according to the above mentioned statement they are in a process of continuous transformation, which however cannot be fully explained at present.

The fact that the temperature in coal mines increases with the depth faster than elsewhere is of practical importance and theoretical interest. A case where it was believed that hot springs were the cause of the high temperature of the mine waters was investigated to find out whether the formation of coal is accompanied by a sufficient generation of heat to explain the high temperatures.

The following results were obtained:

TABLE LXIV.
AVERAGE COMPOSITION OF FUELS. (Muck.)

						Thermal Value. kg-cal.
Wood.....	50% C	6 % H ₂	43 % O ₂	1 % N ₂		= 4800
Peat.....	59% C	6 % H ₂	33 % O ₂	2 % N ₂		= 6000
Lignite.....	69% C	5.5% H ₂	25 % O ₂	0.8% N ₂		= 6800
Bituminous coal.....	82% C	5 % H ₂	13 % O ₂	0.8% N ₂		= 7900
Anthracite.....	95% C	2.5% H ₂	2.5% O ₂	Spur		= 8300

TABLE LXV.
THERMAL VALUE OF THE ELEMENTARY CONSTITUENTS.

Wood.....	$0.50 \times 8080 + 0.06 \times 34,000 = 6080$	kg-cal.
Peat.....	$0.59 \times 8080 + 0.06 \times 34,000 = 6807$	kg-cal.
Lignite.....	$0.69 \times 8080 + 0.055 \times 34,000 = 7445$	kg-cal.
Bituminous coal.....	$0.82 \times 8080 + 0.05 \times 34,000 = 8326$	kg-cal.
Anthracite.....	$0.95 \times 8080 + 0.025 \times 34,000 = 8526$	kg-cal.

The difference between the thermal value of the elementary constituents and the thermal value of the fuels is the heat of formation of the respective fuels (see Table LXVI).

TABLE LXVI.
FORMATION HEAT OF FUELS.

Wood.....	6080 - 4800 = 1280 kg-cal.
Peat.....	6807 - 6000 = 807 kg-cal.
Lignite.....	7445 - 6800 = 645 kg-cal.
Bituminous coal.....	8326 - 7900 = 426 kg-cal.
Anthracite.....	8526 - 8300 = 226 kg-cal.

The heat of formation decreases with the increasing thermal value.

To get an idea about the quantity of fossil fuel produced from wood we have to consider the gases enclosed in the coal, as these gases are also produced in the carbonizing process. They are mainly methane, carbon dioxide and nitrogen. The latter proves admission of air to the coal deposits. Relative to the first two gases we find carbon dioxide mainly in younger coals (lignite) and methane in the older coals (bituminous). We therefore have in the younger coals mainly a formation of CO_2 (heat of formation 8080 cal. per kg. carbon), in the older coals mainly of CH_4 (heat of formation 1833 cal. per kg. carbon). Besides this the formation of H_2O (34,000 cal. per kg. H_2) and of small quantities of heavy hydrocarbons (C_2H_4) can take place.

Since in the progressive process of coal formation, the heat of formation of the elements decreases, while the heat of formation of the generated products of decomposition has a considerable positive value, the heat *balance* of the coal formation is equal to the difference of the heats of formation referred to. The *balance* therefore will be positive if the heat of formation of the products of decomposition is greater than the decrease of the heats of formation of the fuels. For getting this effect only a very small amount of CO_2 , H_2O or CH_4 is required as is shown in Table LXVII.

TABLE LXVII.
DATA ON THE FORMATION HEATS OF FUELS.

Difference between the Heat of Formation of Wood.		This Amount of Heat Corresponds to the Heat of Formation of		
		CO ₂	H ₂ O	CH ₄
and	kg-cal.	In Per cent C or H ₂ of the original Weight of Wood.		
Peat.....	473	5.8% C	1.4% H ₂	25.7% C
Lignite.....	635	7.8% C	1.9% H ₂	34.6% C
Bituminous coal.....	854	10.5% C	2.5% H ₂	46.5% C
Anthracite.....	1054	12.0% C	3.1% H ₂	57.4% C

There is also corresponding to the

Difference between Heat of Formation of	The Formation of		
	C ₂ O	H ₂ O	CH ₄
	From Per Cent		
	Per cent	Per cent	Per cent
Peat and lignite	1.0 C	0.5 H ₂	8.9 C
Lignite and bituminous coal	2.7 C	0.6 H ₂	11.9 C
Bituminous coal and anthracite	1.5 C	0.6 H ₂	10.9 C

If these figures are compared with the difference in the average composition of the various fuels, we see that the formation of coal takes place accompanied by the generation of heat.

For forming an approximate idea of the quantitative changes during the transformation of wood into coal, we are going to deduct the changes from the average composition of the different fuels, following *Griesebach's* (hypothetical) table.

We therefore have for the formation of bituminous wood:



There is given off:

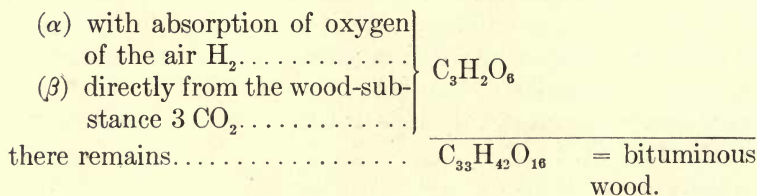

For the other kinds of coal we can imagine the process of carbonification as follows:

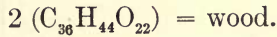

There is given off from wood

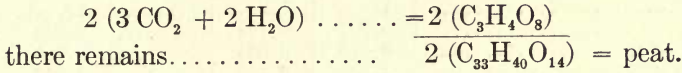

From peat is given off:

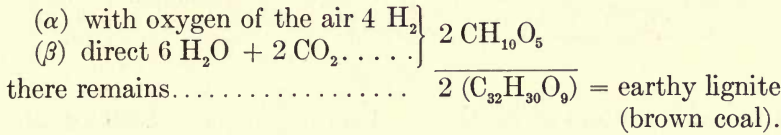

From earthy lignite is given off:

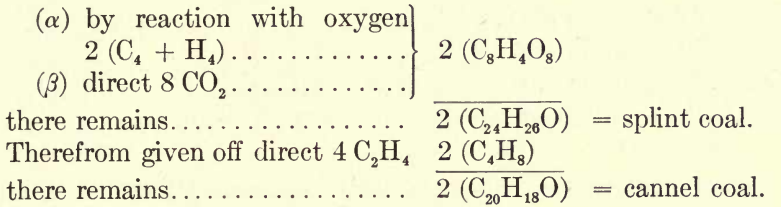

From this is given off:

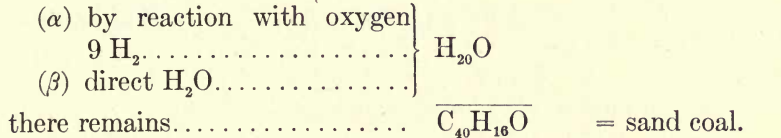

From this is given off:

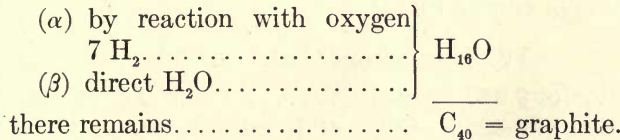

This enables us to calculate the quantity of products of transformation obtained from wood as given in Table LXVIII.

From Table LXVIII we can calculate the heat of formation of the different fuels as given in Table LXIX.

TABLE LXVIII.
PRODUCTS OF TRANSFORMATION OBTAINED FROM WOOD.

Fuel.	Solid Substance kg.	Gases Generated kg.		
		CO ₂	C ₂ H ₄	H ₂ O
Wood.....	1			
Peat.....	0.797	0.159		0.043
Earthy lignite.....	0.674	0.053		0.109
Splint coal.....	0.398	0.425		0.043
Cannel coal.....	0.333		0.067	
Sand coal.....	0.309			0.109
Graphite.....	0.290			0.086
Bituminous wood.....	0.838	0.159		0.022

I. Wood.

Heat of formation of wood..... 1280 kg-cal.

II. Peat.

Heat of formation of 0.797 kg peat..... 643 kg-cal.

Heat of formation of 0.159 kg CO₂ = 347 cal. }
Heat of formation of 0.043 kg H₂O = 170 cal. }..... 517 kg-cal.

Heat of formation of wood minus heat of form.

(peat + CO₂ + H₂O)..... = 120 kg-cal.

The transformation takes place with a consumption of outside energy.

III. Lignite.

Heat of formation of 0.674 kg lignite..... 435 kg-cal.

Heat of formation of 0.053 kg CO₂ = 113 cal. }
Heat of formation of 0.109 kg H₂O = 408 cal. }..... 521 kg-cal.

Heat of formation of peat minus heat of form.

(lignite + CO₂ + H₂O)..... = 313 kg-cal.

The formation of lignite from peat takes place, accompanied by the generation of energy (heat).

IV. Bituminous Coal.

Heat of formation of 0.346 kg coal..... 147 kg-cal.

Heat of formation of 0.425 kg CO₂ = 937 cal. }
Heat of formation of 0.041 kg C₂H₄ = - 27 cal. }..... 1206 kg-cal.
Heat of formation of 0.079 kg H₂O = 296 cal. }

Excess of heat generation over the difference of the

heat of formation of lignite and coal = 1206 -
288..... = 918 kg-cal.

Not considering bituminous wood wherein we find similar conditions as in peat, we have the following excess of heat in the transformation of:

1 kg wood	in 0.797 kg peat = -	120 kg-cal.
0.797 kg peat	in 0.674 kg lignite +	313 kg-cal.
0.674 kg lignite	in 0.346 kg bit. coal +	918 kg-cal.
0.797 kg peat	in 0.346 kg bit. coal +	1231 kg-cal.

These figures are not absolutely correct, as we have supposed only the formation of CO_2 , C_2H_4 and H_2O , while according to analysis, especially of bituminous coal, CH_4 plays an important part. The heat of formation of C_2H_4 , however, is - 642 cal., of CH_4 1833 cal. per one kilogram of carbon, so that we gain + 2475 cal. for every kilogram of carbon which is transformed into CH_4 instead of C_2H_4 , while we lose 6247 cal. for every kilogram of carbon, which escapes as CH_4 instead of CO_2 . Taking even this most unfavorable possibility by supposing that in the process of carbonification exclusively CH_4 and H_2 and no CO_2 at all is generated, we still get the following quantities of heat, which are produced by the reaction

1 kg wood	in 0.797 kg peat = -	138 kg-cal.
0.797 kg peat	in 0.674 kg lignite = +	246 kg-cal.
0.674 kg lignite	in 0.346 kg bit. coal = +	333 kg-cal.
0.797 kg peat	in 0.346 kg bit. coal = +	579 kg-cal.

Similar results were obtained by F. Toldt and F. Fischer.

CHAPTER XI.

PEAT.

PEAT is the youngest member of the fossil fuels, and the result of the first stage of carbonaceous transformation of vegetable matter. It consists mainly of decayed moss and plants growing in bogs and swamps. The peat deposits can be classified according to Stentrupp in forest, meadow and high bogs. While the first is composed of decayed trees and forest plants, the two others can be described (Griesebach) as follows:

	Main Components.	Occurrence.
Moss-peat.....	Sphagnum varieties.....	In all bogs.
Heath-peat.....	Roots and trunks of Erica tetralix and Calluna vulgaris.	In high bogs.
Meadow-peat.....	Roots and trunks of Glumacæ.....	In meadow-bogs.

F. Schwackhoefer proposes the following classification:

1. High bogs (heath and moss bogs) are found in higher altitudes and are characterized by swamp-moss (sphagnum), heath-plants (Calluna, Erica, Andromeda and Vaccinium), also by the occurrence of mountain pine (*Pinus pumilis*). The ground is generally clay and lays above the level of summer water. The surface is always curved. In some localities the bog is 10 to 15 m. thick.

2. Low bogs (meadow-bogs) are found in the territory of rivers, creeks and lakes, and consist of plants entirely different from the high bogs, since swamp and heath plants are entirely absent. Besides some Hypnum varieties, mainly sour grasses are found in this kind of peat. The ground is chalky and below the level of summer water. The layers are not as thick as in high bogs.

There are many connecting links between these two main groups. Without taking into consideration the origin and

occurrence, peat can be classified according to its appearance (Karmarsch) as follows:

- A. Turf-peat (white or yellow).
- B. Young brown and black peat.
 - (a) Fibrous peat.
 - (b) Root-peat.
 - (c) Leaf-peat.
 - (d) Wood-peat.
- C. Old peat.
 - (a) Earth-peat.
 - (b) Pitch-peat.

A. *Turf-peat.* Grayish yellow to yellowish brown color is also called white or yellow peat. Its constituents can be distinctly recognized in the white, spongy, elastic, fibrous mass. Enclosures of roots are rare.

B. *Young brown and black peat.* While the darker color shows a further progress of carbonaceous decay, the organic constituents can yet be distinguished.

- (a) *Fibrous peat* seems to be formed by further decomposition of turf-peat. The fibrous structure is preserved, but the fiber is more brittle and partly earthy; shows less elasticity and is densely pressed by its own weight.
- (b) Other kinds contain short fibers only, and are sometimes earthy to a large extent.
 - (α) Thick, light brown, tough, long fibers (fibrous peat).
 - (β) Containing roots and stems (root-peat).
 - (γ) Containing dried and decayed leaves (leaf-peat).
 - (δ) Containing pieces of coarse wood (wood-peat).

C. *Old peat.* The original organic structure can hardly be distinguished. On account of the progress of decomposition the fibrous texture has gone over into earthy structure, occasionally of such density that the peat shows a sharp and brilliant fracture. Organic residue such as roots and stems are rarely found. The color is brown to pitch black. The strength varies considerably from brittleness to extreme hardness. Accordingly old peat is classified into the following varieties:

- (a) Earth-peat (to which also belong drag-peat and swamp-peat) with earthy texture, rough fracture and practically without fibers.
- (b) Pitch-peat, dense, heavy, strong and with smooth fracture. The average composition of peat is given in Table LXIX.

Ferstel has published the following complete analysis of a peat from Upper Austria:

I. Components soluble in water:

(a) Organic substances with traces of ammonia	1.50 per cent	}	1.65 per cent
(b) Inorganic substances			
CaSO ₄	0.04 per cent	}	0.15 per cent
NaCl	0.01 per cent		
MgCl ₂	0.01 per cent		
Fe ₂ O ₃	0.05 per cent		
Al ₂ O ₃	0.01 per cent		
LiO ₂	0.03 per cent		

II. Components soluble in hydrochloric acid.

(a) Organic substances with traces of ammonia	0.13 per cent	}	3.07 per cent
(b) Inorganic substances:			
P ₂ O ₅	1.07 per cent	}	2.94 per cent
CaO	1.05 per cent		
MgO	0.30 per cent		
Fe ₂ O ₃	0.12 per cent		
MnO	0.04 per cent		
Al ₂ O ₃	0.31 per cent		
LiO ₂	0.05 per cent		

III. Components insoluble in water and hydrochloric acid:

(a) Organic		}	93.36 per cent
Ulmic acid	22.60%		
Ulmic coal	34.70%		
Resin	4.10%		
Wax	1.40%		
Vegetable fiber	16.22%		
(b) Inorganic	0.29%		
(c) Water	14.05%		
Sum	98.08%		

TABLE LXIX.
AVERAGE COMPOSITION OF PEAT.

	Websky.	Schwack- höfer.	Scheerer.	Marsilly.	Knapp.
Composition in Per cent.	Air Dry.	Air Dry.	Free of Water and Ash.		
C.....	49.6-63.9	50-60	45.0	50-54	59.10
H.....	4.7- 6.8	5- 6	4.7	7- 6	5.83
O.....	28.6-44.1	30-35	25.3	} 43-40	} 35.16
N.....	0.0- 2.6	1- 2		
H ₂ O.....		10-20	25.0
Ash.....		5-10

The ash-content of peat varies from 1.50 per cent and has the following average composition:

Sand and clay (mechanically admixed).....	5.70%
Silicic acid (from plants containing silica).....	1.30%
Lime (combined partly with CO ₂ , partly with H ₂ SO ₄)	10.50%
Oxide of iron.....	up to 50%

Only traces of chlorine and alkalis are present. The content of phosphoric acid sometimes exceeds 6 per cent, which has to be considered. A considerable amount of sulphuric acid may also be present.

The specific gravity of peat varies according to structure and quantity of ash. Karmarsch found:

Turf-peat.....	0.113 to 0.263
Young brown peat.....	0.240 to 0.676
Earth-peat.....	0.410 to 0.902
Pitch-peat.....	0.639 to 1.039

By dressing (mechanically purifying) the specific gravity can be increased to 1.3 to 1.4.

Peat is easily ignited (easier, the looser the peat). Very porous varieties show a point of ignition of 200° C.

Peat burns with a long smoky flame.

The thermal value of peat is as follows (in calories):

Peat with 30 per cent water and 10 per cent ash.	2090	Scheerer
Peat with 25 per cent water and free of ash.	3800	Scheerer
Peat with 0 per cent water and 15 per cent ash. . .	4440	Scheerer
Peat with 0 per cent water and 0 per cent ash. . .	5250	Scheerer
Dry peat free of ash.	5250	Tunner
Dry peat with 4 per cent ash.	5090	Tunner
Dry peat with 12 per cent ash.	4686	Tunner
Dry peat with 30 per cent ash.	3636	Tunner
Peat with 25 per cent water.	3800	Tunner
Peat with 30 per cent water.	3313	Tunner
Peat with 50 per cent water.	2182	Tunner

On account of the low specific gravity, the large amount of water and ash, which increases the cost of transportation, also on account of the great variety in quality, peat is only of local importance as a fuel.

Lately peat has been used as a disinfecting material and for coarse textile products.

Production of peat.

1. Cut peat. Peat of sufficient consistency is cut out in the shape of bricks. For the purpose of digging a specially shaped spade is used, with a wing at one side, in order to cut out rectangular blocks.

(a) Peat cut by hand.

(α) Horizontal cut. The bricks are cut out horizontally.

(β) Vertical cut. The bricks are cut out vertically.

(b) Peat cut by machine. (Cutting machine systems, Brosowsky, Diesbach and Hodge.)

The cut peat is either dried in piles in the air or by artificial heat.

2. Molded peat (drag peat). Peat which is too earthy (dry) or too swampy (wet) cannot be cut. If of suitable consistency it is molded (formed) directly, otherwise after previous moistening (in moistening boxes) or desiccating (in tanks or on dry earth). The molding is done as follows:

(a) The wet mass of peat is distributed on level ground fenced in by boards. The peat is given proper consistency

TABLE LXX.
ANALYSES OF PEATS.

Origin.	Composition of Dry Peat.					Moisture of Air Dried Peat	Sp G.	Properties.	Authority
	C Per Cent	H Per Cent	N Per Cent	O Per Cent	Ash Per Cent				
Cappoge, Ireland..	51.05	6.85	39.55		2.55	} to 23%	0.405 0.619 to 0.072	Pale, red-brown. Dark brown, dense. Dark brown. Same. Incompletely decomposed. Solid and dense. Somewhat lighter. Light, felty mass.	Kane Do. Do. Do. Régnauld Do. Walz. Do. Do.
Kulbeggen, Ireland	61.04	6.87	30.46		1.83				
Philipstown, Ireland.	58.69	6.97	1.45	32.88	1.99				
Wood of Allen, Ireland.	61.02	5.77	0.81	32.40	7.90				
Vulcaire, near Abbeville.	57.03	5.63	2.09	29.67	5.58				
Lony, near Abbeville.	58.09	5.93	31.77		4.61				
Framont.....	57.79	6.11	30.37		3.33				
Rammstein, Rheinfalls.	62.15	6.29	1.66	27.20	2.70				
Steinwenden, Rheinfalls.	57.50	6.90	1.75	31.81	2.04				
Niedermoor, Rheinfalls.	47.90	5.8	42.80		3.50				
Prussia.....	50.13 to 55.01	4.20 to 5.36	31.14 to 35.24		8.20 to 21.17	15.17 to 21.7			
Friesland.....	57.16	5.65	33.39		3.80		Dense.....	Mulder	
Friesland.....	59.86	5.52	33.71		0.91		Light.....	Do.	
Holland.....	50.85	4.64	30.25		14.25			Do.	
Bremen.....	57.84	5.85	0.95	32.76	2.6		Dark brown, dense, heavy	Bräuninger.	
Bremen.....	57.03	5.56	1.67	34.15	1.57		Same.....	Do.	
Schopfloch, Württemberg.	53.59	5.60	2.71	30.32	8.10	20.0	Dark brown, dense.	Do.	
Sindelfingen, Württemberg.	45.44	5.28	1.46	26.21	21.60	18.0	Same.....	Do.	
Baden.....	46.75 to 60.79	3.57 to 7.01	0.67 to 6.33	26.87 to 49.01	0.89 to 14.76	11.77 to 18.55		Nessler and Petersen	
Berlin, Havelnieder.	56.43	5.32	38.35		9.86	17.63 *	Heavy, dense, brown.	Jaeckel.	
Berlin, Havelnieder.	53.51	5.90	40.59		6.60	19.32 *	Light, loose.	Do.	
Hamburg, Moor...	57.20	5.32	37.56		2.31	18.83 *	Red brown, heavy	Do	
Grunewald.....	49.88	6.5	1.16	42.42	3.72			Websky.	
Harz.....	50.86	5.80	0.77	42.70	0.57			Do.	
Harz.....	62.54	6.81	1.41	29.24	1.09			Do.	
Limm.....	59.47	6.52	2.51	31.51	18.53			Do.	
Hundsmühl.....	59.70	5.70	1.56	33.04	2.92			Do.	
Haspelmoor.....	58.93	5.72	35.35		8.43	15.50 *	Pressed-peat.	Kraut.	
Neustädter Hütte.	59.61	5.43	31.64		3.32	10.31	Do.....	Do.	
Montanger.....	54.01	4.84	28.56		12.59	17.11	Peat prepared after Challeton.	Do.	
Neufchatel.....	46.78	4.38	28.56		20.28	15.72	Same.....	Do.	
Kolbermoor.....	58.51	6.17	35.32		4.21	15.50 *	Pressed-peat.	Wagner.	
Switzerland.....	40.10	4.53	2.84	21.51	7.87	23.17	Same.....	Goppelsröder.	
Schonen.....	51.38	6.49	1.68	35.43	5.02	1.07	Very dense...	Jacobsen.	

* Calculated free of ash.

by evaporation, trickling of the water into the ground, by pounding, treading and beating. The boards are then removed and the mass cut with sharp knives into regular bricks.

- (b) The mass, compressed from the top is beaten into forms,
 - (α) Containing only one brick (beaten peat).
 - (β) Containing space for several bricks (molded peat).

3. Machine peat.

- (a) Without pressure (machine peat proper). The cut peat is formed into bricks and dried. Occasionally it is previously carded so as to get a denser product.
- (b) With pressure (pressed peat).
 - (α) Dry pressed: small-sized peat is sifted, dried by heat, and briquetted in a heavy brick press. Such peat is expensive on account of the cost of drying and is disintegrated by heat.
 - (β) Wet pressed, most of the water is removed by pressure. There are many constructions of peat-brick presses in successful use.

Peat molded in the form of balls or eggs is very convenient to handle and makes firing easy. Analyses of some dry peats are given on page 171.

CHAPTER XII.

BROWN-COAL (LIGNITE).

BROWN-COAL is the next stage of carbonaceous decay and was formed mostly by transformation of plants rich in resin (coniferous trees, palm tree and cypress; later, also leaved trees).

The specific gravity of this coal varies from 0.8 to 1.8 (in coals very high in ash), but in most cases from 1.2 to 1.5. It has various colors, and the touch is generally brown. In the air brown-coal easily absorbs oxygen and evolves carbon dioxide, whereby on account of the loss in carbon, the thermal value is decreased; at the same time the temperature is increased and in large piles causes spontaneous combustion.

Brown coal does not occur before the tertiary period. The gases found in brown-coal deposits consist generally of carbon dioxide (not of hydrocarbons as in soft-coal deposits). Zitowich published the gas analyses of such coals (Table LXXI).

TABLE LXXI.

ANALYSES OF GASES FOUND IN BROWN-COAL. (Zitowich).

	In Bohemian Patent-Brown Coal.		In Earthy Coal of Inferior Quality.	
CO ₂	89.66	82.40	83.99	
CO.....	1.80	3.00	1.04	
N.....	8.03	14.15	14.91	
O.....	0.51	0.45	0.65	
Sum.....	100.00	100.00	100.59	

Gases from:	Julius-Mine in Bruex (Bohemia).		Coal from Rossitz.	Coal from Habichtswald.
CO ₂	37.62	35.13	31	91
CO.....				9
CH ₄	33.34	36.06	30	
N.....	29.04	28.81	20	
O.....				
C ₂ H ₆			19	

While previously the brown-coals were classified as lignite or fibrous brown-coal, earthy brown-coal and conchoidal brown-coal, Zinken has suggested the following classification:

1. *Common brown-coal*. Compact, more or less dense and strong. The fracture may vary in character from dense to earthy; in structure it may be more or less conchoidal; in appearance it may vary from dead to slightly brilliant; in color from light brown to dark brown, and light-brilliant touch. This coal is between earth coal and pitch-coal, and is produced in all sizes.

2. *Earthy brown-coal*. More or less brittle, light to dark brown, showing dead, uneven fracture, without any organic structure. The lighter varieties burn with a long, the dark ones with a short, but intense flame.

3. *Lignite or fibrous brown-coal*. More or less fossil wood-substance, yellow to dark brown, specific gravity 0.5 to 1.4, fracture depending on the nature of the wood.

4. *Slate-coal*. Slaty, dense, dark-brown to black.

5. *Paper-coal*. Thin, elastic layers of gray to dark-brown color.

6. *Leaf-coal*. Formed of very thin leaves of plants.

7. *Reed-coal*. Reed-like strips formed into ribbon-like layers.

8. *Moor-coal*. Compact without wood-texture, of even, uneven or conchoidal fracture, sometimes slaty, mostly loose, spongy and brittle; dark brown to pitch black. Specific gravity 1.2 to 1.3. Occurs mostly in the lower part of lignite deposits.

9. *Pitch-coal*. Compact, brittle to tough, mostly weak, black-brown to pitch black; has the lustre of pitch or wax. Brown touch; fracture imperfect to conchoidal. Specific gravity 1.2 to 1.3. Occurs near volcanic rocks.

10. *Lustre-coal*. Compact, conchoidal, jet black, very brilliant. The hardest and strongest variety. Specific gravity 1.2 to 1.5.

11. *Gagat* (from the river Gages in Licia). Dense, conchoidal, pitch-black. So strong that it can be worked into ornaments.

12. *Stalky brown-coal*. Like common brown coal but stronger.

The average composition of brown coals is:

Carbon	50 to 65 per cent
Disposable Hydrogen	1 to 2 per cent
Water chemically combined	20 to 30 per cent
Water hygroscopic	10 to 25 per cent
Ash	5 to 10 per cent

The quantity of nitrogen present is nearly always less than 1 per cent. The quantity of water varies as follows:

Fresh-mined coal..... 30 to 40 per cent
 Sometimes up to 60 per cent
 In air-dry coal..... 10 to 30 per cent

Coal which has been completely dried at 100 degrees absorbs in the air from 10 to 15 per cent of moisture. The ash varies from 1 per cent to over 50 per cent; it may contain from 1 to 2 per cent, and sometimes more, sulphur combined with iron (detrimental sulphur).

The organic components in brown-coal are mainly ulmic acid, its derivatives and resinous substances. Otherwise the composition varies considerably even in coals from the same mine.

The following table shows the composition of some brown-coals:

TABLE LXXII.
 COMPOSITION OF BROWN-COALS.

Place.	Gas.	Coke.	Composition of Coal in Per cent.							Thermal Value kg-cal.	
	Yield/ Per cent.		C	H	O	N	H ₂ O	Ash.	Sulphur.		
									Total		Combustible.
I. Austria Hungary:											
(1) Styria:											
Johnsdorf...	25.73	63.32					6.03	4.92	0.96		
Leoben.....	30.07	54.82					10.77	4.34			
Trifail.....			49.95	3.67	16.93	0.97	20.15	8.43		1.64	4386
(2) Bohemia:											
Teplitz.....			44.93	3.21	12.51	0.64	34.28	4.43		0.50	3925
Dax.....			50.12	4.06	13.14	0.65	25.50	6.53		0.93	4630
II. Germany.											
Elbogen.....	26.0		77.64	7.85	14.51						
Cologne.....			63.42	4.98	27.11						
III. France.											
Dax.....	46.6		74.19	5.88	20.13						
Middle Alyses	48.0		72.19	5.36	22.45						
IV. Ireland:											
Lough Neagh.			58.56	5.95	26.85						

As can be seen from the above table the composition of brown-coal of the same origin and mine varies considerably. It is,

therefore, very difficult to get an exact average sample for analysis. For determining the non-uniformity in the composition, the author broke several small pieces from a piece of coal (of Johnsdorf) about the size of a fist. The results of the analysis are given in Table LXXIII.

TABLE LXXIII.
COMPOSITION OF BROWN-COALS.

No. of Test.	Percentage of Hygroscopic Moisture.	Yield in Gas. Percentage.	Percentage of Coal Residuum.	Percentage of Ash.
1	8.49	28.57	53.85	9.09
2	8.02	29.07	53.57	9.34
3	7.77	27.95	54.79	9.49
4	7.63	28.41	54.15	9.81
5	6.87	31.67	52.31	9.15
6	9.13	29.76	53.27	9.94
7	8.17	28.81	53.21	9.81
8	7.24	31.90	51.54	9.32
Average..	7.91	29.52	53.33	9.37

Another series of tests with the same piece are given in Table LXXIV.

TABLE LXXIV.
COMPOSITION OF BROWN-COALS.

No. of Test.	Grams Used.	Weight of the Lead Regulus in Grams.		Oxygen in kg. Theoretically Required for Burning 1 kg. of Fuel.
		Directly Found.	Per 1 g. Fuel.	
1	1.00	21.98	21.98	1.6990
2	1.00	22.31	22.31	1.7245
3	5.00	110.30	22.06	1.7052
4	5.00	109.38	21.88	1.6910
5	5.00	111.59	22.795	1.7252
6	5.00	111.36	22.68	1.7216
7	5.00	111.68	22.34	1.7269
8	5.00	115.42	23.08	1.7841
9	5.00	110.09	22.02	1.7021
10	5.00	112.52	22.50	1.7393
Average..	22.3645	1.72189

Table LXXV gives several analyses of brown-coal ash.

TABLE LXXV.

COMPOSITION OF BROWN-COAL ASH.

Coal Ash from	Artern.	Helmstedt.	Gross-Priessen.	Edelény.	Lignite from Meissner.	Seegraben b. Leoben.	Fohnsdorf.	Koflach (Lignite).
Analyst.	Kremers.	Varrentrapp.	O. Kottig.	Sonnen-schein.		Jüptner		
SiO ₂	3.12	17.27	20.67	36.01	20.5	2.88	13.47	2.52
SO ₃	9.17	33.83	15.45	12.35	30.3			
P ₂ O ₅						0.23	0.13	0.15
CO ₂			13.52			Trace	17.47	10.86
Al ₂ O ₃	29.50	11.57	1.23	23.7	14.7	14.62	5.32	12.17
Fe ₂ O ₃	32.18	5.57		5.05	18.1	39.28	15.96	45.44
MnO				1.13				
Mn ₂ O ₄						7.43	19.86	2.35
CaO	20.56	23.67	45.60	15.62	10.0	34.15	15.67	16.60
MgO	2.16	2.58		3.64	3.4	0.94	0.38	Trace
K ₂ O	0.99	1.90	1.67	2.38	1.9	} 0.47	} 11.71	} 9.91
Na ₂ O	1.72		1.86	0.38				
Chlorine				1.55				
Total	99.40	96.39	100.00	101.81	98.9	100.00	100.00	100.00

CHAPTER XIII.

BITUMINOUS AND ANTHRACITE COALS.

A. BITUMINOUS COAL.

THE older fossil coals, ordinarily called bituminous coals, are mostly black in color and have a high lustre; no organic structure can be discerned without a microscope. The fracture varies. The coals are not hard but brittle.

In destructive distillation they yield more solid residuum and less water than the fuels previously treated and their temperature of ignition is higher.

The great commercial importance of bituminous coals early caused their division into groups, many different schemes being proposed.

Schondorf based his classification on the coking quality:

Coke rough,	{ loose.....	I. Sand-coal.
fine, sandy	{ molten hard, loose in the center..	II. Molten sand-coal
and black.	{ molten hard all over	III. Sinter coal.
Coke gray and solid, opening like a bud.....		III. Baked-sinter-coal.
Coke smooth, metallic, strong.....		V. Baking coal.

Gruner based the following classification on the character of the flame:

I. Long-flame sand-coals (sand-coal rich in gas) can be used for reverberatory furnaces and as inferior gas coal. They burn with long, smoky flame, crack in the heat, and disintegrate without baking.

Sand coal. — Composition of coal substance:

$$\begin{aligned} \text{C} &= 75 \text{ to } 80 \text{ per cent} \\ \text{H} &= 5.5 \text{ to } 4.5 \text{ per cent} \\ \text{O} + \text{N} &= 19.5 \text{ to } 15.5 \text{ per cent} \end{aligned}$$

The ratio of (O + N) to H equals 3 or 4.

By destructive distillation these coals yield from 50 to 60 per cent of sandy to slightly molten coke, evaporate from 6.7 to 7.5

times their weight of water and have a thermal value of 8000 to 8500 cal.

The soot-coal, which is of fibrous structure and contains only 3 per cent of hydrogen also belongs to this class.

II. Long-flame baking coals (long-flame caking coals, gas-coals, sinter and baking coals rich in gas) are used mainly as flaming coals and gas-coals, less suitable for coking (however, in special ovens a coke of medium quality can be produced). They burn with a long, smoky flame, get soft in the heat and fritted. (Coals standing in quality between these coals and the long-flame sand-coals are called sinter-coals).

Composition of coal substance:

$$\begin{aligned} \text{C} &= 80 \text{ to } 85 \text{ per cent} \\ \text{H} &= 5.8 \text{ to } 5 \text{ per cent} \\ \text{O} + \text{N} &= 14.2 \text{ to } 10 \text{ per cent} \end{aligned}$$

The ratio of (O + N) to H equals 2 or 3.

Coke residuum of destructive distillation 60 to 68 per cent (perfectly molten, not baked). These coals evaporate 7.6 to 8.3 times their weight of water and generate 8500 to 8800 cal.

III. Baking coals proper (medium-flame caking coal, forge coal), especially adapted to coking, gas making and heating. Burn with less smoke and more brilliant flame than the previous kinds, melt in the heat and bake together to solid masses.

Composition of coal substances:

$$\begin{aligned} \text{C} &= 84 \text{ to } 89 \text{ per cent} \\ \text{H} &= 5 \text{ to } 5.5 \text{ per cent} \\ \text{O} + \text{N} &= 11 \text{ to } 5.5 \text{ per cent} \\ \frac{\text{O} + \text{N}}{\text{H}} &= 1 \text{ or } 2. \end{aligned}$$

Coke residuum by destructive distillation from 68 to 74 per cent; the coke is molten and more or less puffed. These coals evaporate from 8.4 to 9.2 times their weight of water and generate from 8800 to 9300 cal.

IV. Short-flame baking or caking coals (coking coal poor on gas). Best coking and boiler coal. Difficult to ignite, burns with an illuminating, short, slightly smoky flame. Cakes somewhat in the heat.

Composition of coal substance:

$$\begin{aligned} \text{C} &= 88 \text{ to } 91 \text{ per cent} \\ \text{H} &= 5.5 \text{ to } 4.5 \text{ per cent} \\ \text{O} + \text{N} &= 6.5 \text{ to } 4.5 \text{ per cent} \\ \frac{\text{O} + \text{N}}{\text{H}} &= \text{about } 1. \end{aligned}$$

Coke-residuum of destructive distillation from 74 to 82 per cent. The coke is molten, and compact. These coals evaporate from 9.2 to 10 times their weight of water, and generate from 9300 to 9600 cal.

V. Anthracitic coals (poor in gas, older sand-coals). Especially adapted to shaft furnaces, boilers and domestic uses. Cannot be coked. Difficult to ignite; burn with short, weak and practically non-smoking flame. Cakes slightly in the heat and frequently disintegrates.

Composition of coal-substance:

$$\begin{aligned} \text{C} &= 90 \text{ to } 93 \text{ per cent} \\ \text{H} &= 4.5 \text{ to } 4 \text{ per cent} \\ \text{O} + \text{N} &= 5.5 \text{ to } 3 \text{ per cent} \\ \frac{\text{O} + \text{N}}{\text{H}} &= \text{about } 1. \end{aligned}$$

Residuum of destructive distillation from 82 to 90 per cent, slightly molten, mostly sandy. These coals evaporate from 9 to 9.5 times their weight of water and yield from 9200 to 9500 cal.

A similar classification was made by Hilt. If we determine the ratio (in weight) of volatile matter to the coke dried at 100 degrees and free of ash, we get the results shown in Table LXXVI.

TABLE LXXVI.
CLASSIFICATION OF COAL. (Hilt.)

Kind of Coal.	Ratio of Residuum, Free of Ash and Vol- atile Matter.
I. Anthracite	1 : 20 to 1 : 9
II. Semi-caking sinter-coal (poor in gas)	1 : 9 to 1 : 5.5
III. Caking or baking coal.....	1 : 5.5 to 1 : 2
IV. Baking gas-coal.....	1 : 2 to 1 : 1.5
V. Sinter-coal rich in gas.....	1 : 1.5 to 1 : 1.25
VI. Sand-coal rich in gas.....	1 : 1.25 to 1 : 1.11

Expressing the volatile matter as given in Table LXXVI in per cents free of ash, we get the results given in Table LXXVII.

TABLE LXXVII.

CLASSIFICATION OF COAL. (Hilt.)¹

Kind of Coal.	Volatile Matter. Per cent.
I. Anthracite.....	5 to 10
II. Semi-caking coal.....	10 to 15.5
III. Caking coal.....	15.5 to 33.3
IV. Baking gas-coal.....	33.3 to 40
V. Sinter-coal rich in gas.....	40 to 44.4
VI. Sand-coal rich in gas.....	44.4 to 48

Dr. E. Muck based a classification on simple laboratory experiments.

If a small quantity (about a teaspoonful) of finely powdered coal is quickly heated, preferably in a platinum crucible, until no flame is visible at the cover, the quality of the cooled residuum varies according to the coal used, as follows:

Powder, just like the coal-powder used . . . I. Sand-coal.
Somewhat molten, partly powder II. Molten sand-coal.
Molten but not puffed III. Sinter-coal.
Molten, somewhat puffed IV. Caking sinter-coal.
Thoroughly molten and puffed up in a
form similar to a potato V. Caking coal.

The properties are the same in using the fuel on a large scale. In heating under admission of air (grate-firing), I, II, and III do not melt; but IV and V do melt to such an extent as to clog the grate openings, so that only I, II and III can be used under boilers and for household purposes.

If melting (caking) coals III and IV are slowly and gradually heated, they do not melt properly and the coke-residuum is poor-looking, soot-black and strongly puffed. This also takes place at high temperature and too large an air supply, since the fusible coal substance is destroyed by long heating (partial degasification) and excess of air (oxidation). If caking coal is heated for

some time in the open air (to about 300 degrees), it no longer cakes at all if afterwards heated to a high temperature.

Depending on the fact, whether the coal sample is heated to high (normal test) or low temperature (puffing test) the coke obtained shows different volume and color. After heating to a high temperature the volume is smaller than after heating to a low temperature. The color after the normal test is more or less brilliant, silver-white, after the puffing test black and not brilliant. We find the same phenomena in coke ovens at low and high temperature.

Considering besides the quality of the coke, the fusibility and the flame of the coal, the classification given in Table LXXVIII can be used (Muck).

TABLE LXXVIII.
CLASSIFICATION OF COALS.

Quality.	Elementary Composition of the Coal, Dry and Free of Ash, in Per cent.			Yield in Coke, Per cent.	Quality of Coke.	Specific Gravity.
	C	H	O			
I. Dry bituminous coal with long flame.	75	5.5	19.5	50	Powdered or fritted.	1.25
	to 80	to 4.5	to 15.0	to 60		
II. Baking bitum. coal with long flame, or gas coal.	80	5.8	14.2	60	Molten and rimous.	1.28 to 1.3
	to 85	to 5.0	to 10.0	to 68		
III. Baking coal proper, or forge coal.	84	5.0	11.0	68	Molten and compact.	1.3
	to 89	to 5.5	to 5.5	to 74		
IV. Baking bituminous coal with short flame, or coke-coal.	88	5.5	6.5	74	Molten, very compact, slightly rimous.	1.3 to 1.35
	to 91	to 4.5	to 5.5	to 82		
V. Semi-anthracitic coal.	90	4.5	5.5	82	Fritted or powdered.	1.35 to 1.4
	to 93	to 4.0	to 3.0	to 90		

From these figures we see the relation and connection between the properties of the coals and their chemical compositions. But there are also cases of isomerism where coals of about identical composition show an entirely different behavior in heat.

TABLE LXXIX.

CLASSIFICATION OF COALS.

Occurrence.	Composition of Coal, Dry and Free of Ash, in Per cent.			Yield of Coke, Per cent.	Quality of Coke.
	C	H	O+N		
Niederwuschnitz, Saxony ..	82.34	4.73	12.93	66.43	Sandy.
Zwickau, Saxony	82.59	4.76	12.65	77.29	Caked.
Alma Mine, Flöz 4, West- phalia.	87.47	5.03	7.50	75.80	Slightly molten.
President Mine, Dickebank, Westphalia.	87.79	4.78	7.24	77.60	Caked and strongly puffed.

Coal deposits are not at all homogeneous, and we can generally distinguish the following components:

1. Malting coal, jet black, brittle, brilliant, easily split perpendicularly to its layers.

2. Dull coal, brown to gray-black, hardly any brilliancy, stronger and less brittle. Is not scissile and shows rough fracture.

Malting coal is the only constituent of sand and sinter-coals, semi-baking, and is the principal constituent of the baking and coking coals, while gas-coal consists of alternate layers of malting and dull-coal. A coal extremely rich in dull coal is called cannel-coal. Since the malting coal occurs in every kind of coal, it is self-evident that it has widely varying composition and fusibility. The dull coal is usually richer in ash and always richer in hydrogen and gas than the malting coal.

3. Fibrous coal is widely distributed in all parts of the coal-deposits, forms generally thin layers, is similar to charcoal (therefore called mineral charcoal) is infusible, low in volatile matter and is therefore detrimental in coke and gas production.

4. Bituminous shale, *i.e.* slate impregnated with coal substance, is frequently similar to cannel-coal. The coal substance of bituminous slate is rich in hydrogen. The moisture of freshly mined coals varies. In air-dry state they contain from 2 to 4 per cent, sometimes up to 8 per cent of water. The ash varies from 2 to 20 per cent. For some special metallurgical uses, the com-

position of the ash has to be considered, as a coal rich in sulphur or phosphor is detrimental for certain uses.

TABLE LXXX.
ANALYSES OF BITUMINOUS COALS.

Locality.	Gas.	Coke.	Composition of coal in Per cent.							Sulphur Per cent.		Thermal Value kg-cal.
	Yield in Per cent.		C	H	O	N	H ₂ O	Ash.	Total.	Combust- ible.		
Austria:												
Kladus.....			59.48	3.55	8.89	1.16	7.90	19.02				5497
Pilsen.....			75.09	4.51	8.41	8.41	6.08	5.31				7098
Karwin.....		70.5	68.80	3.99	8.23	1.36	5.65	11.97			0.90	6420
Maehr. Ostrau.....			77.21	4.00	8.32	1.39	2.41	6.07			0.68	7296
Germany:												
Upper Silesia.....			73.20	4.93	19.11			2.76				
Saarbrücken.....			72.38	4.46	15.05			8.11				
Aachen.....			89.32	3.80	2.71			4.17				
Essen.....			85.62	4.65	5.93	1.71		2.09				
Bochum.....			85.90	4.56	4.77	1.56		3.21				
Westphalia.....		69.9	79.82	4.96	4.79	1.25	3.00	5.36	0.82			
France:												
St. Etienne.....	19.75	79.0	84.54	4.77	4.59	0.84	1.25	4.00				8392
England:												
Tyldesley.....	32.08	57.75	74.46	5.10	8.25	1.52	6.07	4.08	0.49			7069
Bickershaw.....	29.81	63.87	78.93	4.90	7.24	1.57	4.36	1.96	1.04			7465

By dressing and washing, the ash-content can be considerably decreased.

Of technical importance is the decomposition of coal in the atmosphere by absorption of oxygen, which takes place in two stages; at first the available hydrogen and some carbon are oxidized to water and carbon dioxide; in the second stage oxygen is absorbed by the coal, but no carbon dioxide nor water escapes, so that an increase in weight takes place, sometimes as much as 4 per cent. Thereby not only the thermal value, but also the property of caking and the yield of coke is decreased.

By this absorption of oxygen and oxidation the coal is heated, sometimes to such a high temperature that not only the included gases escape (causing decrease in weight) but also spontaneous combustion can take place. This spontaneous combustion is facilitated by the oxidation of pyrite, which is present in the

coal. The gases included in bituminous coals vary in composition as follows:

Methane.....	0 per cent to 90 per cent.
Carbon dioxide.....	0.2 per cent to 54 per cent.
Oxygen.....	trace to 17 per cent.
Nitrogen.....	10 per cent to 90 per cent.

The quantity varies between 18 and 190 cu. cm. in 100 g. of coal.

TABLE LXXXI.

ANALYSES OF BITUMINOUS COALS. (G. Arth.)

BITUMINOUS COAL FROM THE FRANKENHOLZ MINE WITH 8.1 PER CENT OXYGEN.

	Ash. Per cent.	C Per cent.	H Per cent.	O Per cent.	C Per cent.	H ₂ Per cent.
					of Organic Compounds.	
Fresh mined.....	2.08	81.69	5.79	8.15	83.42	5.91
After 12 months:						
In running water.....	1.75	82.24	5.70	7.88	83.70	5.80
In stagnant water.....	1.82	82.15	5.62	7.94	83.67	5.72
Exposed to the weather.....	1.96	81.45	5.58	8.80	83.08	5.49

BITUMINOUS COAL FROM DROCOURT (PAS DE CALAIS) WITH 3.7 PER CENT OXYGEN.

Fresh mined.....	4.08	85.06	5.20	3.68	88.68	5.42
After 12 months:						
In running water.....	4.33	85.70	5.26	2.71	89.58	5.49
In stagnant water.....	4.78	84.67	4.87	3.74	88.92	5.11
Exposed to the weather.....	5.77	82.78	5.00	4.54	87.84	5.30

BITUMINOUS COAL FROM AISEAU-PRÊLE (CHARLEROI) WITH 1.6 PER CENT OXYGEN.

Fresh mined.....	2.86	89.83	3.88	1.59	92.41	3.99
After 12 months:						
In running water.....	2.64	89.30	3.79	2.61	91.70	3.89
In stagnant water.....	3.31	89.01	3.84	2.05	92.05	3.97
Exposed to the weather.....	3.19	88.77	3.99	2.38	91.69	4.05

B. ANTHRACITE.

Anthracite is the last stage of carbonaceous decay. It is black, very hard and strong, has generally conchoidal fracture (sometimes it is very slaty), and has a specific gravity of 1.40 to 1.80.

Anthracite burns without smoke, with a short, weak, reddish flame. By distillation an extremely small quantity of volatile matter is obtained. The composition of the organic component is:

C 93 to 95 per cent
 H 4 to 2 per cent
 O + N 3 per cent
 —————
 100 per cent.

TABLE LXXXII.

ANALYSES OF ANTHRACITES.

Occurrence.	Gas Per cent.	Coke C Per cent.	C Per cent.	H Per cent.	O Per cent.	N Per cent.	H ₂ O Per cent.	Ash Per cent.	Sulphur Per cent.	Thermal Value Cal.	Observer.
Denver, Ruby Mine, U.S.A.			87.56	3.11	2.69	0.13	0.72	4.15	0.89	} Fischer.
Denver, Anthracite Mine, U.S.A.			89.49	3.33	1.19	0.66	0.59	4.00	0.78	
Pennsylvania, Wilkesbarre.			86.91	2.80	3.89		5.97	0.43	Schultze.
..... Do.	2.75	87.90	86.456	1.995	1.449	0.75	3.45	5.90	7484	P. Mahler.
Tonking, Kebao.	4.56	85.19	85.746	2.733	2.671	0.60	2.80	5.45	7828 Do.
Turacher-Alpe Styria.			84.14	2.55	4.18	4.31	4.82	7339	R. Schöffel.
Werchzirm- Alpe, Styria.			75.48	2.05	3.88	2.56	16.03	6560 Do.

The distillation yields:

Powdered coke 90 to 92 per cent
 Gas 10 to 8 per cent

—————
 100 per cent.

The anthracites are of the greatest importance in America, where they occur in immense deposits. They are of no importance in Europe.

Suggestions for Lessons.

Examination of various solid fuels. Elementary and intermediate analysis, fuel tests, ash analysis.

Determination of the density and of the weight of 1 cu. m.

Examination of green and seasoned fuels.

Determination of the quantity and composition of the included gases.

CHAPTER XIV.

ARTIFICIAL SOLID FUELS.

FOR certain purposes it is advantageous to use fuels richer in carbon than the ones occurring in nature. Such fuels are prepared by destructive distillation of the natural solid fuels, whereby the following products of decomposition are formed: (1) gases; (2) tar; (3) tar water, and (4) residuum rich in carbon.

The quality and quantity of the products of decomposition depend on the nature of the raw material, temperature of decomposition and other circumstances. With increasing temperature the output of gas increases both as to weight and volume, but simultaneously the quantity of heavy hydrocarbons in the gas decreases, and therefore also the illuminating power of the gas.

The pressure under which the distillation is carried out is also of importance relative to the products formed.

The advantages of producing carbonized (coked) fuels are:

1. A fuel of higher thermal value is obtained.
 - (a) As the carbon-content of the coked fuel is higher than that of the natural fuel.
 - (b) As the volatile substances in spite of their combustibility, require for their gasification a considerable amount of heat, which is at our disposal when we use coked fuels.

Thereby the cost of transportation per heat unit is decreased.

2. Combustion of coked fuels is smokeless.
3. Coked fuel does not bake.
4. Coked fuel contains less sulphur than does raw fuel.
5. Under certain conditions valuable by-products can be collected. On the other hand coking has the following disadvantages:

1. The carbonizing (coking) of the natural fuels requires a certain amount of heat, fuel, wages and machinery.

2. Coked fuel burns with a short flame, while for certain operations a long flame is essential.

3. The ash-content is increased by coking.

Heat of formation of 1 kg. of a fuel is the number of calories which were set free by the formation of such fuel from its elements, and which naturally have to be added again for the decomposition into the elements. Heat of decomposition is obtained by deducting the directly observed heat of combustion of the fuel from the sum of the heats of combustion of the elementary components.

Schwackhöfer found for Ostrau (Austria) nut coal:

C	73.55 per cent
H ₂	4.54 per cent
O	11.38 per cent
N	0.46 per cent
Hygr. H ₂ O	2.44 per cent
Ash	5.63 per cent
Combustible sulphur	0.60 per cent
Thermal value	7433 cal.

The heat of combustion of the elementary components of this coal are:

C	$0.7355 \times 8080 = 5942.84$	cal.
H ₂	$0.0454 \times 29,600 = 1343.84$	cal.
S	$0.0060 \times 2500 = 15.00$	cal.
Total	<u>6301.68</u>	cal.
Thermal value of coal deduct	<u>7433.00</u>	
Heat of formation of 1 kg. coal -	<u>1131.32</u>	cal.

For coal from Leoben (Styria) Schwackhöfer found:

C	60.91 per cent
H ₂	4.22 per cent
O	17.99 per cent
N	0.71 per cent
Hygr. H ₂ O	9.92 per cent
Ash	6.25 per cent
Combustible sulphur	0.52 per cent
Thermal value	6013 cal.

The heat of combustion for the elementary components is:

C.....	0.6091 ×	8080 =	4921.53 cal.
H.....	0.0422 ×	29,600 =	1249.12 cal.
S.....	0.0052 ×	2500 =	13.00 cal.
Total.....			6183.65 cal.
Thermal value of coal deduct.....			6013.00 cal.
Heat of formation of 1 kg. coal + 170.65 cal.			

The heat necessary for gasifying coal depends on the nature of the gasification, *i.e.* the nature of the products of decomposition. If the gasification is effected by destructive distillation, the heat necessary equals the difference of the heat of formation of the coal and the heat of formation of the distillation products (from the elements). The heat necessary for gasifying can also be calculated by deducting the thermal value of the distillation-products (calorimeter) from the thermal value of the coal.

Therefore the heat required for the destructive distillation of 1 kg. of this coal is 254.792 cal.

According to the nature of the raw material, the coked materials are named:

1. Charcoal.
2. Peat-coal.
3. Coke; to the class of artificial fuels belong also the
4. Briquettes.

TABLE LXXXIII.
COMPOSITION AND PRODUCTS OF DESTRUCTIVE DISTILLATION OF COAL.
(P. Mahler.)

Substance.	Percentage of Elementary Composition.						Thermal Value in Cal.	Yield in Kg. from 100 Kg. of Coal.	Thermal Value of Products in Cal.	
	C	H ₂	O	N	Ash	H ₂ O				
Bitum. coal of Com-mentry.....	75.182	5.176	8.202	0.94	7.05	3.45	7423.2	100	742326.0	
Coke.....	85.773	0.414	2.043	0.62	10.27	0.88	7019.4	65.66	460893.8	
Tar from hydraulic main.....	90.186	4.848	4.966				8887.0	3.59	31904.3	
Tar from tar collector.....	89.910	4.945	5.145				8942.8	0.87	7780.2	
Tar from cooler.....	87.222	5.499	7.279				8831.0	1.46	10243.9	
Tar from condenser.....	85.183	5.599	9.218				8538.4	1.89	16137.6	
Gas.....	55.086	21.460	23.454				11111.0	17.09	189887.0	
Ammonia water.....							17 g. per liter		9.36	
Total.....									99.62	716846.8
Heat lost in destruc-tive distillation.....										25479.2
Coke used as fuel.....							7019.4		21.09	148053.2

CHAPTER XV.

CHARCOAL.

THE dry distillation of wood yields

- (a) Hygroscopic water.
(b) Illuminating gas, consisting mainly of

Acetylene, C_2H_2 .
Ethylene, C_2H_4 .
Benzol, C_6H_6 .
Naphthalene, $C_{10}H_8$.
Carbon Monoxide, CO.
Carbon Dioxide, CO_2 .
Methane, CH_4 .
Hydrogen, H_2 .

- (c) Tar, consisting of

Benzol, C_6H_6 .
Naphthalene, $C_{10}H_8$.
Paraffin, $C_{20}H_{42}$ to $C_{22}H_{46}$.
Retene, $C_{15}H_{18}$.
Phenol, C_6H_6O .
Oxyphenic Acid, $C_6H_6O_2$.
Kresylic Acid, C_7H_8O .
Phlorylic Acid, $C_8H_{10}O$.
Creosote $\left\{ \begin{array}{l} C_7H_8O_2 \\ C_8H_{10}O_2 \\ C_9H_{12}O_2 \end{array} \right.$
Resins

- (d) Pyroligneous acid, consisting of

Acetic Acid, $C_2H_4O_2$.
Propionic Acid, $C_3H_6O_2$.
Acetone, C_3H_6O .
Wood Alcohol, CH_4O .

- (e) Charcoal.

Charcoal contains, besides carbon, H, O and ash, and generally also hygroscopic water. The average composition of air-dry charcoal is

C (including H and O)	85 per cent
Hygroscopic H ₂ O	12 per cent
Ash.....	3 per cent
	<hr/>
	100 per cent.

Tamm takes the average composition of charcoal as follows:

	Air-Dry		Perfectly Dry	
C.....	75.5	} 90.0 per cent	83.0	} 98.9 per cent
O.....	12.0		13.2	
H.....	2.5		2.7	
Ash.....	1.0		1.1	
Hygr. H ₂ O.	9.0			
	<hr/>		<hr/>	
	100.0		100.0	

According to the researches of Violette on charring wood, the wood remains unchanged up to a temperature of 200° C; at 232° C. it gets brown; between 270 and 350° C. red coal and at 400° C. black coal is formed.

The so-called red wood, which stands between red and black coal, has the following composition (Fresenius):

C.....	52.66 per cent
H.....	5.78 per cent
O.....	36.64 per cent
Ash.....	0.43 per cent
H ₂ O.....	4.49 per cent
	<hr/>
	100.00 per cent.

Violette's researches comprise the following series:

1. Coals made at different charring temperatures (150° to over 1500° C.) from one kind of wood (*Rhamnus frangula*).
2. Coals from the same wood produced at different temperatures in entirely closed vessels.
3. Coals from those kinds of wood which are mainly used in France for gunpowder manufacture.
4. Coals made at 300° C. from 72 different varieties of wood.

TABLE LXXXIV.
DATA ON THE CHARRING OF WOOD.

No.	Per cent lost by Drying at 150° C.	Charring Temperature in Deg. Cent.	Volatile Matters Generated from 100 Parts of Wood dried at 150°C.	Weight of Coal Obtained	Elementary Components in 100 Parts of Coal.				Remarks.	Temperature of Charring Corresponds to	
					C	H ₂	O + N + Loss.	Ash.		The Melting Point of	Deg. Cent.
1	15.00	150	2.00	100.00	47.5105	6.1200	46.290	0.080	Wood dried at 150° C.		
2	17.17	160	5.45	98.00	47.6055	6.0645	46.271	0.085			
3	17.17	170	5.45	94.55	47.775	6.159	45.9535	0.098			
4	14.04	180	11.41	88.59	48.936	5.840	45.123	0.117			
5	14.36	190	18.01	81.99	50.6145	5.115	44.0625	0.2215			
6	17.28	200	22.90	77.10	51.817	3.9945	43.976	0.2265	Partly dried wood, partly charred wood.		
7	15.40	210	26.86	73.14	53.3735	4.903	41.538	0.200			
8	15.80	220	32.50	67.50	54.570	4.1505	41.3935	0.217			
9	12.73	230	44.65	55.37	57.1465	5.508	37.047	0.3145			
10	14.58	240	49.21	50.79	61.307	5.507	32.7055	0.515			
11	13.16	250	51.35	49.57	65.5875	4.810	28.967	0.652			
12	14.76	260	58.77	40.23	67.8905	5.038	26.4935	0.5955			
13	12.91	270	62.86	37.14	70.4535	4.6415	24.192	0.8535	Red coal just beginning to get brittle (for hunting powder).		
14	14.94	280	65.84	36.16	72.6395	4.705	22.0975	0.568			
15	14.45	300	65.91	34.09	72.494	4.981	21.929	0.910			
16	13.69	300	66.39	35.61	73.236	4.2585	21.962	0.769			
17	12.54	310	67.37	32.67	73.663	5.8295	21.8125	0.918			
18	14.52	320	68.77	32.20	73.5735	4.8505	21.333	0.755			
19	14.38	330	68.47	31.53	75.202	4.626	19.962	0.4775			
20	16.37	350	70.34	29.66	76.642	4.469	18.441	0.613			
21	12.98	432	81.13	18.87	81.6435	4.196	15.2445	1.1625			Antimony
22	13.90	1023	81.25	18.75	81.9745	4.188	14.1483	1.5975			Silver
23	13.90	1100	83.2925	17.702	83.2925	4.702	13.7933	1.2245			Copper
24	13.84	1250	82.06	17.94	88.1385	1.415	9.2595	1.199			Gold
25	14.60	1300	82.54	17.46	90.811	1.5835	6.4895	1.1515			Steel
26	14.60	1500	82.69	17.31	94.566	0.7395	3.8405	0.664			Iron
27	14.60	1500	85.00	15.00	96.517	0.6215	0.936	1.9455			Platinum

* Melting platinum.

For these experiments the wood was cut into cylindrical pieces of 1 cm. diameter and dried in a current of steam at 150° C. The charring (except in the second series) was effected up to 350° C. with superheated steam, at higher temperature in a crucible at the melting point of antimony, copper, silver, gold, steel, iron, and platinum.

The results of the first series are given in the table on page 193.

TABLE LXXXV.
YIELD OF COAL BY CHARRING. (Karsten.)

Kind of Wood.	Rapid Distillation.	Slow Distillation.		
	Karsten.	Karsten.	Stolze.	Winkler.
Oak wood, young.....	16.54	25.60	} 26.1	22.8
Oak wood, old.....	15.91	25.71		
Red beech, young.....	14.87	25.87	} 24.6	17.8
Red beech, old.....	14.15	26.15		
White beech, young.....	13.11	25.22	} 23.8
White beech, old.....	13.65	26.45		
Alder, young.....	14.45	25.65
Alder, old.....	15.30	25.65
Birchwood, young.....	13.05	25.05	24.4	17.6
Poplar.....	28.8	17.7
Birchwood, old.....	12.20	24.70	24.4	17.6
Birchwood, well preserved.....	12.15	25.10
Red pine, young.....	14.25	25.25	} 23.4	20.6
Red pine, old.....	14.05	25.00		
Fir wood, young.....	16.22	27.72	} 21.5	20.1
Fir wood, old.....	15.35	24.75		
Pine, young.....	15.52	26.07	} 23.7
Pine, old.....	13.75	25.95		
Linden.....	13.30	24.60	22.8	16.2
Ash.....	21.1	19.4
Willow.....	22.2	15.0
Rye straw.....	13.40	24.60
Fern.....	17.00	27.95

The tests show that quick coking yields only about half as much charcoal as slow coking.

Violette obtained by charging wood into a preheated (432 degrees) charring vessel about 8.96 per cent coal, while he obtained 18.87 per cent by heating the same kind of wood for six hours gradually up to 432 degrees.

In the second series of Violette's experiments the wood pieces (*Rhamnus frangula*) were weighed, dried at 150° C. and were kept in closed glass tubes at constant temperature with superheated steam. The results were:

TABLE LXXXVI.
YIELD OF COAL BY CHARRING.

No.	Temperature of Charring.	Quantity of Wood Dried at 150° C.	Weight after Distillation.			Elementary Compounds in 100 Parts of Coal.				Remarks.
			Carbon.	Liquid.	Gases.	C	H ₂	O + N + loss.	Ash.	
1	160° C.	100 Tl. 100 "	97.4	1.6	1.0	} 49.0175	5.3045	45.5325	0.154	The wood became brown and the tube light brown.
			98.0	1.0	1.0					
2	180° C.	100 Tl. 100 "	93.0	2.0	5.0	} 56.5235	6.1680	37.0940	0.198	Red brown coal. The tube covered with reddish tar drops.
			93.2	1.8	5.0					
3	200° C.	100 Tl. 100 "	87.7	2.3	1.0	} 61.0420	5.2470	33.4270	0.294	Coal of ordinary structure. Heavy tar deposit in tube.
			87.4	2.6	1.0					
4	220° C.	100 Tl. 100 "	84.3	2.7	1.3	} 66.4185	4.9830	28.0150	0.5885	Black coal of ordinary appearance.
			86.4	1.6	1.2					
5	240° C.	100 Tl. 100 "	85.0	2.0	1.5	} 67.1340	5.1675	25.9230	1.7705	Same.
			82.5	2.5	1.5					
6	260° C.	100 Tl. 100 "	82.5	2.5	1.5	} 67.6215	5.0995	25.2580	2.0315	Black coal covered with drops of molten tar.
			82.8	2.2	1.5					
7	280° C.	100 Tl. 100 "	83.8	1.2	1.5	} 64.6010	5.4245	26.7680	3.2005	Black coal very hard. Appearance of a substance in the first stage of melting.
			82.7	2.3	1.5					
8	300° C.	100 Tl. 100 "	78.6	3.4	1.8	} 67.5760	4.5655	27.3270	0.5855	Black molten mass without a trace of structure of wood.
			76.2	3.7	1.8					
9	320° C.	100 Tl. 100 "	78.7	1.3	2.0	} 65.6185	4.7600	25.5425	4.0720	Black, brilliant, entirely molten coal, somewhat like baked soft coal.
			78.7	1.3	2.0					
10	340° C.	100 Tl. 100 "	79.1	0.9	2.0	} 77.0705	4.7065	14.0415	3.8375	Substance similar to molten, fat, bituminous coal.
			78.5	1.5	2.0					

The third series of experiments with coals made from different kinds of wood showed the variable composition of the charcoal obtained. Violette found in the interior part of the apparatus coal with 85 per cent carbon, on the walls with 70 per cent of carbon.

In the fourth series of experiments 72 kinds of wood were dried for two hours with steam of 150° C. and then charred for three hours with steam of 300° C. The results were as follows:

TABLE LXXXVII.
YIELD OF COAL BY CHARRING.

No.	Kind of Wood dried at 150 Degrees, Charred at 300 Degrees.	Yield of Coal, Per cent.	No.	Kind of Wood dried at 150 Degrees, Charred at 300 Degrees.	Yield of Coal Per cent.
1	Cork wood	62.80	37	Currant bush	35.66
2	Ebony	54.30	38	Medlar tree	35.57
3	Satinwood	52.00	39	Cherry bush	35.53
4	Willow (foul)	52.17	40	American aspen	34.87
5	Wood from Herculaneum	49.69	41	Hooded milfoil	34.85
6	Wheat straw	46.99	42	Ivy	34.75
7	Oak	46.09	43	Hawthorn	34.70
8	Yew tree	46.06	44	Plane-tree	34.69
9	Mahogany	44.89	45	Apple-tree	34.69
10	Beech	44.25	46	Elm-tree	34.59
11	Ironwood	43.75	47	Hornbeam	34.44
12	Juniper	43.07	48	Alder-tree	34.40
13	Pockwood	41.86	49	Barberry	34.28
14	Moor pine	41.48	50	Furze	34.24
15	Poplar (leaves)	40.95	51	Birch-tree	34.17
16	Poplar (root)	40.90	52	Plum-tree	34.06
17	Fir	40.75	53	Sycamore	33.70
18	Fungus growing on willows	40.64	54	Maple	33.75
19	Box	40.44	55	Willow	33.74
20	Lote-tree	40.35	56	Alder — buckthorn	33.61
21	Bird cherry	40.31	57	Virginian acacia	33.42
22	Palm-tree	39.49	58	Flowery dogwood	33.36
23	Thuja, Canadian	39.44	59	Broom	33.33
24	Hemp stalk	39.22	60	Ash-tree	33.28
25	Virgin's bower	38.83	61	Quince-tree	33.28
26	Rush	38.46	62	Hazel-tree	32.79
27	Cocoonut-tree	37.93	63	Bird cherry	32.70
28	Carded cotton	37.41	64	Holly-tree	32.21
29	Elder-tree	37.31	65	Alaternus	32.05
30	Varnish-tree	37.27	66	Guelder-rose	32.03
31	Rose-tree (wild)	37.21	67	Pear-tree	31.88
32	Honeysuckle	36.96	68	Linden	31.85
33	Spindle-tree	36.60	69	Lilac	31.84
34	Vine	36.53	70	Begonia	31.33
35	Chestnut	36.06	71	Poplar	31.12
36	Bean trefoil	36.01	72	Horse-chestnut	30.86

The conclusions that can be drawn from Violette's experiments are:

1. Wood yields less coal the higher the temperature. For the same kind of fuel the yield for instance is:

At 250° C.....	50 per cent weight,
At 300° C.....	33 per cent weight,
At 400° C.....	20 per cent weight,
At 1500° C.....	15 per cent weight.

2. From woods treated at the same temperature the yield of coal is proportional to the time of distillation. With slow distillation the yield is twice as great as with quick distillation.

3. The carbon content of the coal is proportional to the temperature of distillation; the coal contains for instance:

At 250° C.....	65 per cent,
At 300° C.....	73 per cent,
At 400° C.....	80 per cent,
At 1500° C.....	96 per cent.

4. By distillation in perfectly closed vessels very little carbon is gasified, as most of the carbon is retained in the coal in solid form on account of the increased pressure. This explains the higher yield in retorts as compared to pile-charring.

5. The charring of wood in perfectly closed vessels yields at 280° C. 80 per cent of red coal, while by means of superheated steam only 40 per cent can be obtained. This is due to the increased pressure, which changes the equilibrium towards a smaller volume.

6. In perfectly closed vessels wood melts at from 300 to 400° C. under formation of a black, brilliant mass, without any organic structure, similar to melted pitch-coal.

7. Coals produced in cylinders or iron pots are of variable composition (70 to 84 per cent C.), while with superheated steam — according to temperature — coal of any constant composition can be made.

The red coal used in gunpowder manufacture is nothing but half-charred wood of red-brown or brown-black color. It burns with a long illuminant flame and therefore contains less carbon and more hydrogen than charcoal proper (black coal).

Good charcoal is black in color with a steel-blue lustre. It has a distinct wood structure, conchoidal fracture, low specific gravity (0.17 to 0.24), is fairly strong, easily ignited, and burns with a very short, blue, smokeless flame.

By lying in the atmosphere charcoal absorbs about 10 per cent of water; if moistened directly with water, 50 per cent is absorbed.

WEIGHT OF CHARCOALS (Petraschek).

Charcoal.	100 Liters Weigh, Kg.
From soft wood, average.....	17
From hard wood, average.....	24
Hard and soft wood mixed...	21

The loss of volume of charcoal during transportation, etc., by breakage and friction is, according to Wessely:

Decrease in Volume. Per cent.	Carting.		Sleighing.	
	Limits.	Average.	Limits.	Average.
Hours according to quality of road.				
1.....	3-8	5½	3-6	5
2.....	1¼-3½	2½	1¼-3	2¼
3.....	1-3	2	1-2½	1½
4.....	1-2	1½	1-1½	1¼

One volume of charcoal from boxwood absorbs the following quantities of gas (Saussure):

NH ₃90 vol.	CO ₂35 vol.
HCl.....85 vol.	CO.....9.42 vol.
SO ₂65 vol.	O.....9.25 vol.
H ₂ S.....55 vol.	N.....7.50 vol.
NO ₂40 vol.	CH ₄5.00 vol.
C ₂ H ₄35 vol.	H ₂1.75 vol.

0.59 g. of different kinds of coal absorb the quantities of different gases (in cu. cm.) given in Table LXXXVIII.

TABLE LXXXVIII.
ABSORBING CAPACITY OF COALS.

Gases.	Charcoal.	Peat.	Bone Black.
NH ₃	98.5	96.0	43.5
HCl.....	45.0	60.0
H ₂ S.....	30.0	28.5	9.0
CO ₂	14.0	10.0	5.0
O.....	0.8	0.6	0.5
SO ₂	32.5	27.5	17.5

The temperature of ignition depends on the temperature of distillation as shown in Table LXXXIX.

TABLE LXXXIX.
TEMPERATURE OF IGNITION OF CHARCOAL (Violette).

Temperature of Charring.	Temperature of Ignition.
300° C.	360-380° C.
260-280° C.	340-360° C.
290-350° C.	360-370° C.
432° C.	400° C.
1000-1500° C.	600-800° C.
Melting point of platinum.	1250° C.

We can classify as follows the different methods of producing charcoal.

- A. Charring in the woods or carbonizing under movable cover (with changeable volume of the charring apparatus).
- (a) Without recovery of by-products.
 - (α) in pits. { (1) vertical.
 - (β) in piles { (2) horizontal.
 - (b) With recovery of by-products.
 - (α) in pits.
 - (β) in piles.
- B. Charring in apparatus with constant volume of the charring space.
- (a) Pile-charring (the heat required is generated in the interior of the coking space).
 - (α) The heat necessary for charring is furnished by partly burning the wood to be charred (piles with admission of air to the interior).
 - (β) The heat necessary for charring is furnished by combustion by gases free of oxygen (piles with admission of combustion gases free of oxygen to the interior).
 - (γ) The heat is furnished by superheated steam.
 - (b) The heat for charring is furnished from outside.

A. Charring in the woods.

(a) Charring without recovery of by-products.

(α) Charring in pits.

The pits are about 1 m. deep, 2 m. wide at the top, somewhat narrower at the bottom. The fire is started with brushwood, then the wood is piled up and covered with earth. The coal is light and unequally burned.

(β_1) Charring in round piles.

These piles have generally the form of a paraboloid, and their cubic content is calculated according to the formula

$$\frac{d^2\pi}{4} \cdot \frac{h}{2} = \frac{d^2h\pi}{8},$$

or, as on the finished pile, the circumference can be figured more easily than the diameter:

$$\frac{u^2}{\pi^2} \cdot \frac{\pi}{4} \cdot \frac{h}{2} = \frac{u^2h}{8\pi} = \frac{u^2}{25.31} \cdot h.$$

As, however, the shape of the piles is not exactly like a paraboloid, from 4 to 6 per cent is deducted from the volume calculated according to above formula.

The following varieties of wood are mainly used for charring in piles:—of coniferous trees: pine, fir, red pine, and larch; of leaved wood: oak, red beech, white beech, ash, elm, alder, and birch. The most favorable age of trees for charring is given in Table XC.

TABLE XC.
PROPER AGE OF TREES FOR CHARRING. (Scheerer.)

Wood.	Age of most Perfect Development.	Age at which Tree can be cut.
Pine.....	140	80 to 100
Red pine.....	150	70 to 80
Fir.....	80 to 100	60
Larch.....	80 to 90	50
Oak.....	200 to 250	50 to 60
Red beech.....	} 120 to 140	120
White beech.....		
Elm.....	80	20 to 30
Alder.....	...	18 to 20
Birch.....	40	20

In winter time the wood contains less moisture than in summer; winter is therefore the most favorable time for cutting the wood. For the erection of piles, locations are selected that are protected from wind, and a ground not too dry and not too wet. A dry ground will break and crack, allowing too much air to enter into the pile. A wet ground generates steam, which, with the glowing coal, is decomposed into hydrogen and carbon dioxide. In both cases a loss of coal results. The foundation ground of the pile, which is a little inclined towards the center, is first of all covered with a layer of culm coal. In the center a strong, straight post (center pole) is driven into the ground (Slavic piles, Figs. 32 and 33), or three posts of even length are driven in, forming an equilateral triangle, the length of the sides being about 20 cm. These three posts form the center shaft (Italian piles, Fig. 34). Logs are now laid around the center of the charcoal kiln (pile), either vertical as in Fig. 34, or horizontal, or both ways combined, as shown in Fig. 33. Depending on the size of the pile, one, two, or more layers of logs are put together, the upper layer always being less steep than the lower. Small logs are used to fill the spaces between the large logs. The upper layer is covered with small logs and small pieces of wood, for rounding the shape of the pile (peak of the pile). In piles with center shafts the logs are always vertical, except the dome, which consists of horizontal logs. In these piles the center shaft is used for starting the fire, while in piles with a center post a channel is left open for this purpose on one side of the bottom part, extending to the center. The pile is then covered on the outside with branch wood, then with leaves and grass (smoke cover), and at last with earth, sand, and coal culm (earth cover). This cover does not reach to the ground (Fig. 32, *C, D*), but is supported by timber. For starting the fire some kindling wood is put in on the bottom at the center.

The fire is started by inserting glowing coal in the kindling wood through the center shaft or through the above-mentioned channel. Then the shaft is filled with small pieces of wood and covered. The fire now extends upwards and to the sides; the hygroscopic water is evaporated and condenses again on the surface of the pile (the pile sweats). Then acid gases and later combustible gases escape, and wherever they get mixed with air an explosion takes place, throwing off parts of the cover or parts of

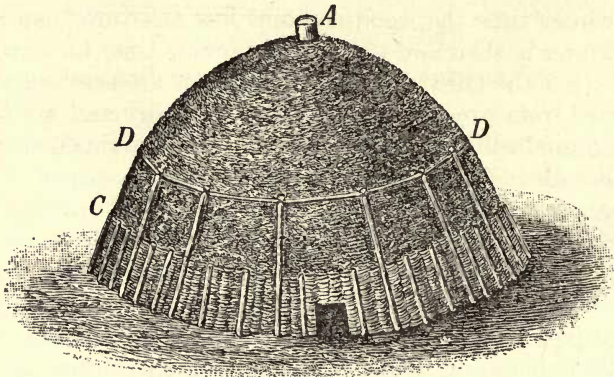

FIG. 32. — Slavic Pile.

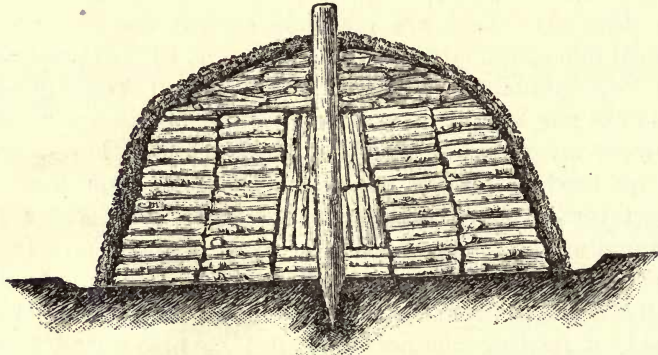

FIG. 33. — Slavic Pile.

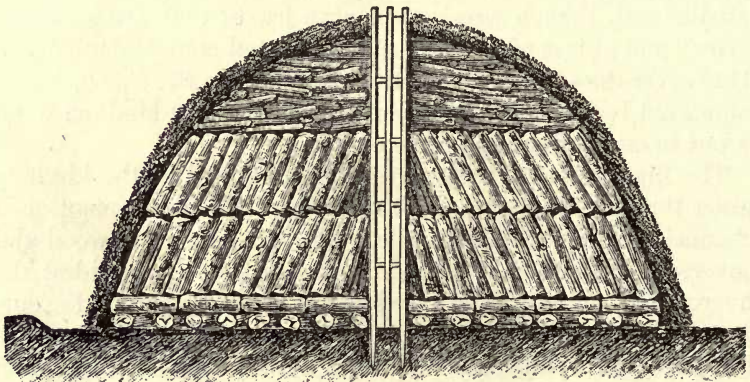

FIG. 34. — Italian Pile.

the pile. Such damage to the pile has to be repaired instantly. This first period of charring lasts from 18 to 24 hours.

Meanwhile the center shaft is burned out and pieces of wood have to be filled in again and again until the period of sweating is over. The bottom of the pile is now also covered, and by making openings into the cover (driving the pile) the fire is drawn gradually to the lowest parts. The upper openings are closed as soon as blue smoke starts to escape, the lower as soon as the flame shoots through.

The "drawing" of the coal is performed by removing the cover on one side and cooling the hot coal with cold water.

The coal is marketed in the following sizes:

(1) Lump coal; (2) blacksmith coal; (3) small size; (4) culm; (5) half-charred wood.

According to the size of the pile (120 to 300 cu. m.) the process of charring requires from 15 to 20 days.

Probably the largest pile kilns are operated at Neuberg (Styria, Austria). They are built up to 400 to 430 cu. m. capacity, the 500 cu. m. size having been abandoned on account of difficulty of regulation. Red pine and red beech are charred at Neuberg in separate piles. The following data, gathered from these plants might be of interest:

1 cu. m. hard wood half dry weighs	550 kg.
1 cu. m. soft wood half dry weighs	400 kg.
1 cu. m. (cord wood) hard wood green weighs	900 kg.
1 cu. m. (cord wood) hard wood half dry weighs	700 kg.
1 cu. m. (cord wood) hard wood dry weighs	580 kg.
1 cu. m. (cord wood) soft wood green weighs	800 kg.
1 cu. m. (cord wood) soft wood half dry weighs	600 kg.
1 cu. m. (cord wood) soft wood dry weighs	400 kg.
100 liters hard coal weighs	23 kg.
100 liters soft coal weighs	14 kg.

The piles have a diameter of 14 m., a height of 4.7 m., and a cubic content of 400 cu. m. of wood. They are built with five layers of log wood of 1 m. height. The yield of such a pile is

Piece coal (large pieces) 2000 hectoliters	} 60 per cent volume of the wood,
Piece coal (small pieces) 400 hectoliters	
Culm.	1 per cent,
Half-charred wood.	1 per cent.

TABLE XCI.
COMPOSITION OF KILN GASES. (Ebelmen.)

No.	Hours after Starting.	Appearance of Gas.	Composition in Per Cent. (Volume.)			
			CO ₂	CO	H ₂	N ₂
1	48	white opaque.....	25.57	8.68	9.13	56.62
2	72	white opaque.....	26.68	9.25	10.97	53.40
3	96	white opaque.....	27.23	7.67	11.64	53.46
4	66	white transparent.....	23.51	5.00	4.89	66.60
5	71	fairly transparent.....	23.28	5.88	13.53	57.31
6	95	bluish and transparent.....	23.08	6.04	14.11	55.77

The time required is:

Erection of pile..... 4 days,
 Starting fire..... $\frac{1}{2}$ hour,
 Charring process..... 18-28 days,
 Removing charcoal..... 4 days.

In working shifts:

Erection 4 days per 10 men..... 40 shifts,
 Covering with branch wood 1 day per 2 men..... 2 shifts,
 Covering with leaves..... 2 shifts,
 Covering with earth 1 day per 12 men..... 12 shifts,
 Charring, average..... 8 shifts,
 Removing charcoal 4 days per 8 men..... 32 shifts,
 Preparing ground..... 2 shifts,
 Night-watch (average)..... 2 shifts,

100 shifts.

The temperature of the escaping gas right below the cover was from 230 to 260° C. One liter of same showed the following content of condensable products (tar, water, etc.):

1. White and opaque..... 0.987 g.
 2. Similar to A..... 1.068 g.
 3. Bluish and transparent..... 0.531 g.

(β_2) Charring in rectangular piles.

The horizontal piles are not circular but oblong, generally having a length of from 9.5 m. to 12.5 m. and a width of from 2 to 3 m. (Fig. 35). They are surrounded by posts which are connected by timbers. The logs are put in perpendicular to the

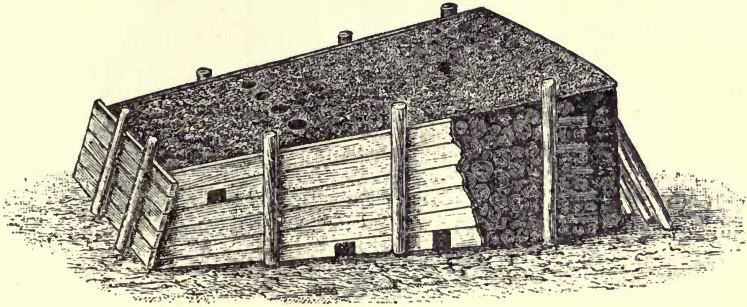

FIG. 35. — Rectangular Pile.

longitudinal axis of the pile. The hollow spaces are filled out with branch wood. The height in front is about 0.6 and increases towards the back part at an angle of from 15 to 20 degrees. The fire is started in the front and goes slowly through the entire length of the pile.

(b) Charring in the woods with recovery of by-products.

(α) When charring in pits a vessel covered with a grate is put on the bottom for collecting the tar.

(β) In pile-charring (for recovering by-products) iron pipes are put into the cover, leading to a condensing chamber. This is done 24–36 hours after starting the fire, as in the first period almost nothing but steam escapes.

Fig. 36 shows a French pile with a channel leading to a tar-collecting vessel. About 20 per cent of tar is obtained.

B. Charring in apparatus with constant volume of the charring space.

(a) Pile-charring.

(α) The heat necessary for charring is furnished by partly burning the wood to be charred (piles with admission of air to the interior).

As an example we will describe the round pile oven (kiln), Fig. 37, which has a grate on the bottom for the admission of air, the quantity of the latter being regulated by means of the ash-

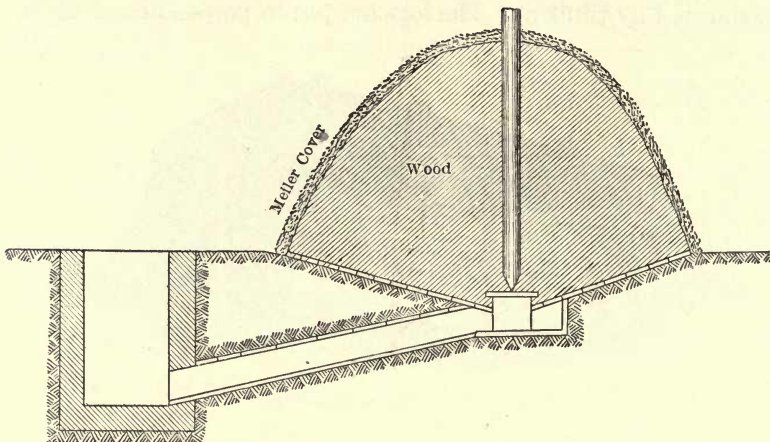

FIG. 36. — French Pile.

door. The wood is charged first through the main door, then through the upper charging-chute. After starting the fire the main door is closed with bricks and mortar and as soon as steam

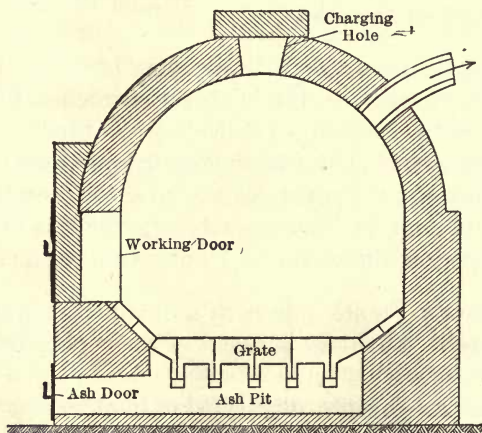

FIG. 37. — Round Pile Oven.

and tar begin to escape, the upper charging-chute is also closed, so that the escaping gases have to go through the pipe shown at one side of the cover (dome) to the condensing vessels. When the oven is sufficiently heated, the ash-door is closed. When

the charring is finished, the oven is allowed to cool and the coal removed through the main door.

(β) Charring in pile-oven with admission of combustion gases free of oxygen to the interior.

Such an oven was built by Grill for the iron works in Dalfors (Sweden), Figs. 38 and 39. It is rectangular and provided with

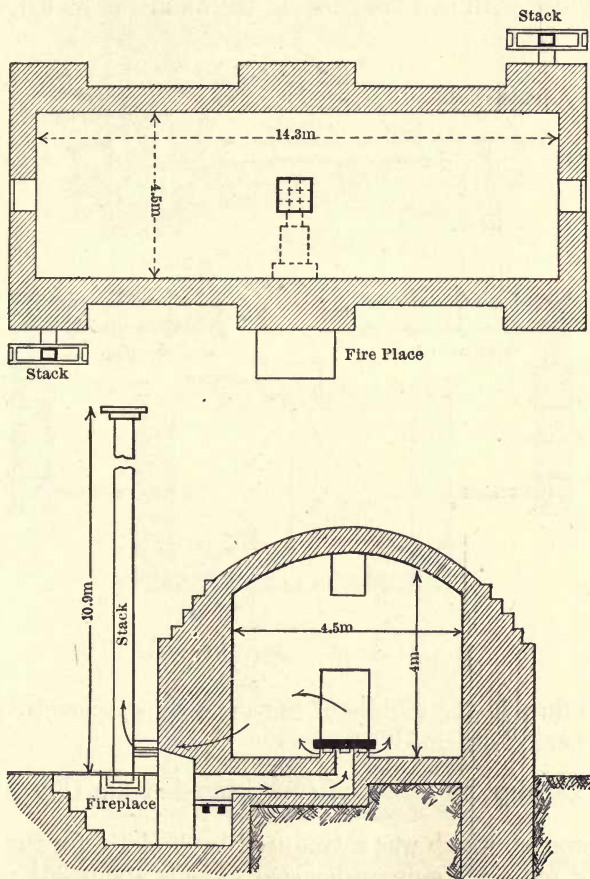

FIGS. 38 and 39. — Grill's Pile Oven.

charging openings on both short sides. The gases of combustion rise from a fireplace below the oven, pass vertically through the center of the oven and escape in four directions through side-flues. The volatile products of distillation escape through two

channels arranged in opposite corners, and pass through iron-pipes to a tar-collecting vessel, the stack being arranged above this vessel. After getting the fire up, the oven is closed tight. A charge consists of 172.26 cu. m. of wood; 37.58 cu. m. of wood are used for heating; the yield is 147.31 cu. m. charcoal. The wages per cu. m. of charcoal at this plant are 6.25 cents.

The Schwartz oven is of similar construction, Figs. 40 and 41. It is provided with two fireplaces in the middle of its length, and

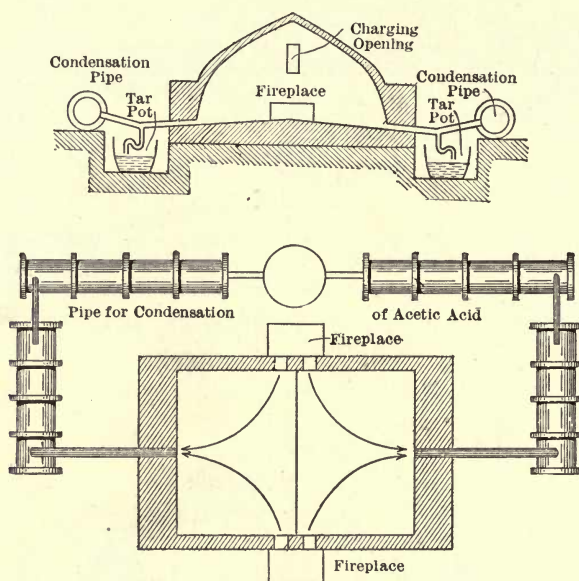

Figs. 40 and 41. — Schwartz Oven.

with two flues in the middle of the short sides, whereby a more uniform heat is obtained.

(γ) Heating by means of superheated steam (Fig. 42).

This process, which was introduced by Violette for the manufacture of red coal (gunpowder coal), yields about $36\frac{1}{2}$ per cent of red coal and no black coal, and is therefore very much superior to the old process by which 14.18 per cent red coal and 17.81 per cent black coal (total 31.99 per cent) is obtained. Fig. 42 shows a longitudinal section. Steam from a boiler is led through a coil located in the oven. By the direct fire the steam in the coil is

superheated. The fire gases play around the retort and escape through the flue. The superheated steam from the coil enters the sheet-iron cylinder (retort), which is closed in front with a wrought-iron cover, and then passes into the inner cylinder, which is charged with the wood to be charred. Steam and

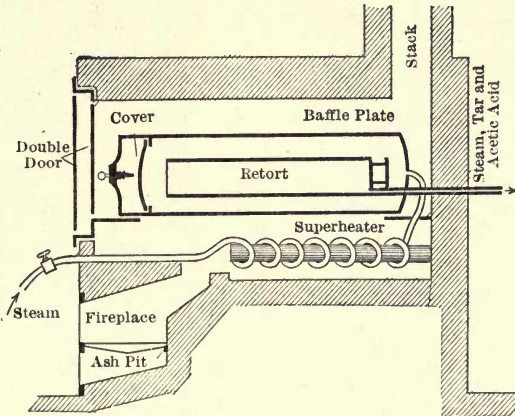

FIG. 42. — Charring with Superheated Steam.

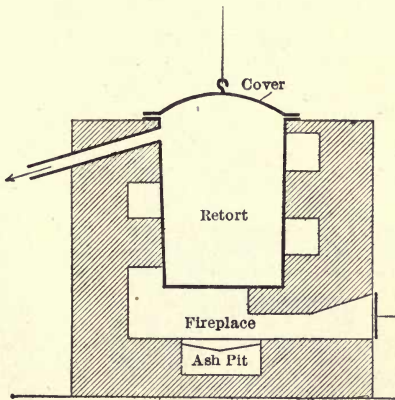
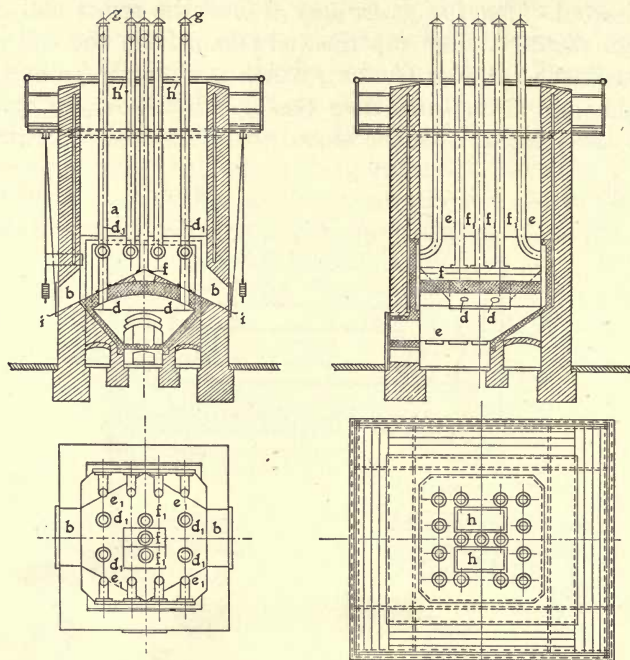

FIG. 43. — Section through French Oven heated from the Outside.

products of distillation escape through a pipe into the atmosphere or into a suitable condensing apparatus. Opposite the entrance of steam a baffle-plate is provided for distributing the steam.

(b) Charring by heat supplied from the outside.



Figs. 44-47. — Pile Retort Oven.

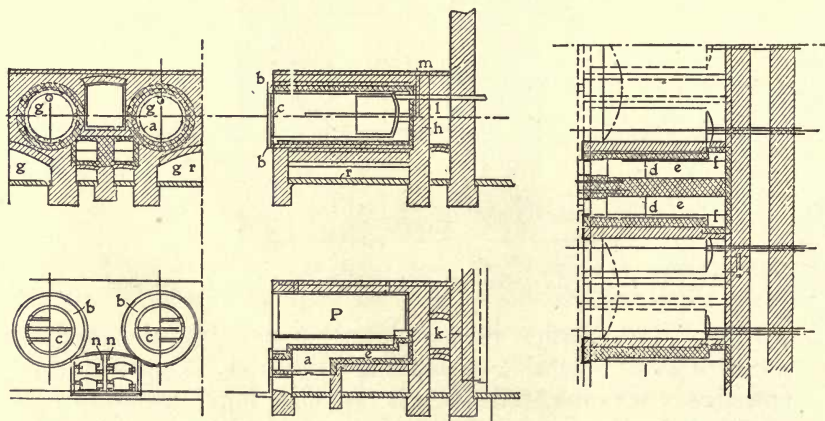

Figs. 48-52. — Ovens with Horizontal Retorts.

Charring is performed in retorts or large cylindrical vessels. In Russia, vertical sheet-iron cylinders are used, having a cubic content of about 8 cu. m.: a special fireplace is provided for heat-

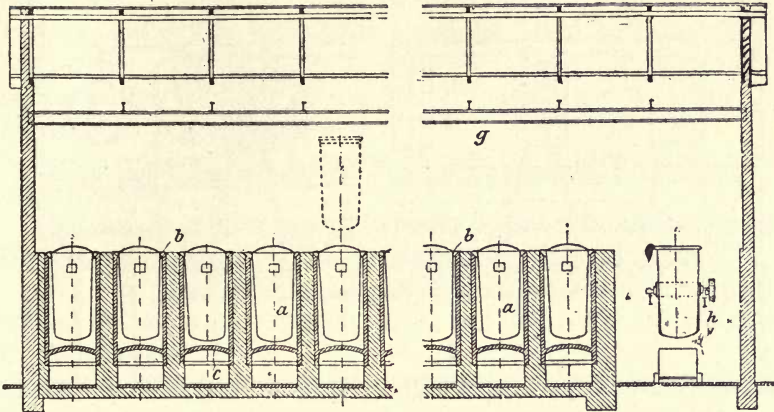

FIG. 53. — Longitudinal Section of a Modern Charring Plant with Vertical Retorts.

ing the vertical shell. For quickly preheating the wood to 100 degrees, steam is admitted at the bottom of the cylinder. The tar flows through a pipe arranged at the bottom, to a collecting

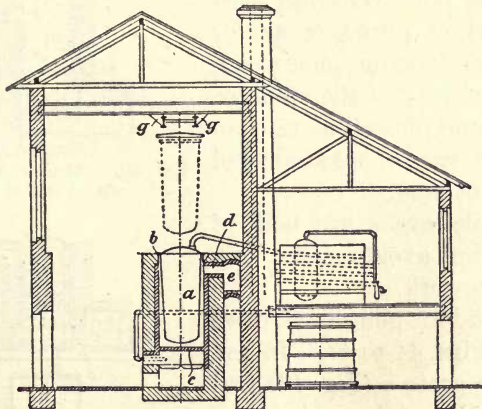

FIG. 54. — Cross-section of a Modern Charring Plant with Vertical Retorts.

vessel, while the vapors leave through a pipe on the top, and go to a condensing apparatus, from which the condensed tar passes to the above-mentioned collecting vessel. The products of dis-

tillation pass through a cooled pipe, while the combustible gases are lead back into the fire.

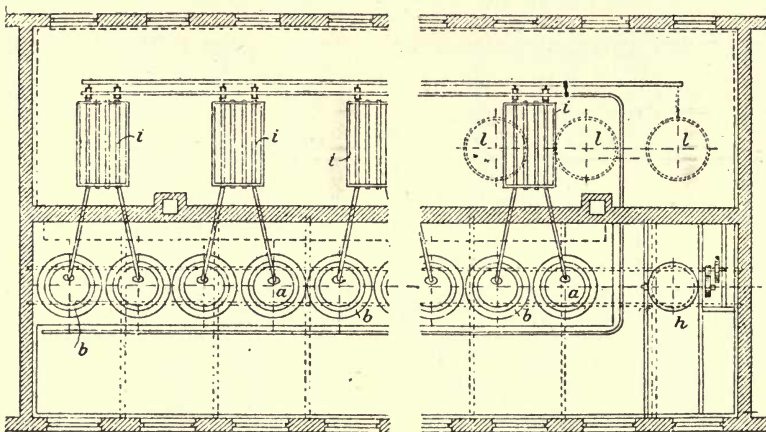

FIG. 55. — Plan of a Modern Charring Plant with Vertical Retorts.

Fig. 43 shows a vertical section through a French oven of similar type. Vertical, horizontal and inclined retorts are used with equal success for charring wood.

At present pile ovens are used only for certain purposes, as, for instance, for charring pine wood, where the recovery of the valuable Swedish tar and pine oil more than pays for the loss of wood-alcohol and acetate of lime.

Modern pile ovens are built of sheet iron for avoiding the loss through brickwork.

Such a modern pile-retort oven is shown in Figs. 44 to 47. In the fireplace the grate *e* (Fig. 46) and the arch *dd* (Fig. 44) can be seen. Through the arch the fire gases go into the pipes *f*, while another part of the fire gases goes upwards near the arch and enters the pipes, *e*. All these vertical pipes go

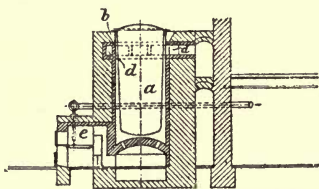

FIG. 56. — Modern Charring Plant with Vertical Retorts.

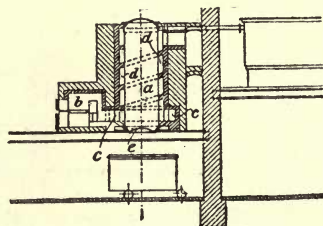

FIG. 57. — Oven with Stationary Permanent Retorts.

All these vertical pipes go

through the interior of the pile-retort. The doors *bb* are used for discharging.

Similar ovens with horizontal retorts are shown in Figs. 48 to 52. Figs. 53 to 56 show a modern charring plant with vertical retorts. The retorts *a* can be lifted out of the furnace by a crane *g*, and can be brought to a suitable place for charging or discharging. Fig. 57 shows an oven where the retorts remain in permanently; they are discharged into small cars that can be moved right under the retorts.

To the rotary retort, however, belongs the future of the charcoal industry.

The increase of the charcoal industry is shown by the following figures, which relate to this industry in Austria-Hungary:

About 30 years ago the output of charcoal was about 10,000 cu. m., ten years later 120,000 cu. m., and today it is 350-400,000 cu. m. per year.

For the prosperity of forestry this industry is of the greatest importance, as only hereby are we enabled thoroughly to utilize widely distributed forests (by the utilization of refuse wood).

CHAPTER XVI.

PEAT-COAL, COKE AND BRIQUETTES.

THE destructive distillation of peat, lignite or coal yields:

(1) gases, (2) tar, (3) tar water, and (4) a solid residue very high in carbon, which, depending on the raw material used, is called peat coal or coke.

For conveying an idea of the process of destructive distillation, we give below tables for the two extreme cases (peat and bituminous coal).

DESTRUCTIVE DISTILLATION OF PEAT. (H. Vohl.)

100 parts of peat of a Swiss bog yielded by destructive distillation:

17.625 gas	{	Heavy Hydrocarbons, C_nH_{2n} Methan, CH_4 Hydrogen, H_2 Carbon Monoxide, CO									
5.375 tar	{	Tar 0.820 sp. g. Heavy Oil 0.855 sp. g. Paraffin									
25.00 tar water	{	<table style="border-collapse: collapse; width: 100%;"> <tbody> <tr> <td style="vertical-align: middle; padding-right: 5px;">bases</td> <td style="font-size: 1.5em; vertical-align: middle; padding-right: 5px;">{</td> <td style="vertical-align: middle;"> Ammonia Methylamin Picolin Lutidin Anilin Caespidin </td> </tr> <tr> <td style="vertical-align: middle; padding-right: 5px;">acids</td> <td style="font-size: 1.5em; vertical-align: middle; padding-right: 5px;">{</td> <td style="vertical-align: middle;"> CO_2 H_2S CyH Acetic Acid Propionic Acid Butyric Acid Valerianic Acid </td> </tr> <tr> <td style="vertical-align: middle; padding-right: 5px;">water</td> <td style="font-size: 1.5em; vertical-align: middle; padding-right: 5px;">{</td> <td style="vertical-align: middle;"> Phenol </td> </tr> </tbody> </table>	bases	{	Ammonia Methylamin Picolin Lutidin Anilin Caespidin	acids	{	CO_2 H_2S CyH Acetic Acid Propionic Acid Butyric Acid Valerianic Acid	water	{	Phenol
bases	{	Ammonia Methylamin Picolin Lutidin Anilin Caespidin									
acids	{	CO_2 H_2S CyH Acetic Acid Propionic Acid Butyric Acid Valerianic Acid									
water	{	Phenol									
25.00 peat coal	{										

DESTRUCTIVE DISTILLATION OF BITUMINOUS COAL.

(R. Wagner.)

100 parts gas coal of the following composition:

C.....	78.0 per cent
Disposable H ₂	4.0 per cent
N.....	1.5 per cent
S.....	0.8 per cent
H ₂ O chemic combined.....	5.7 per cent
H ₂ O hygroscopic.....	5.0 per cent
Ash.....	5.0 per cent

 100.0 per cent.

Products of dry distillation:

1. 70-75 parts of coke { carbon containing H₂ and O, 90-95%
Fe₇S₈ and earthy matters, 10- 5%
2. Tar water (ammonia water) containing
 - (α) Main components (water, carbonate of ammonia and sulphide of ammonia).
 - (β) Additional components (chloride, cyanide and sulfo-cyanide of ammonia).
3. Tar, containing:
 - (α) Liquid hydrocarbons (Benzol, Tolnol, Pseudocumul, Cyanol, Propyl, Butyl, etc.).
 - (β) Solid hydrocarbons (Naphthalin, Acetylnaphthalin, Anthracen, Reten, Chrysen, Pyren).
 - (γ) Substances containing oxygen (Phenol, Kresol, Phlorol, Rosolic Acid, Oxyphenolic Acid, Creosote, Pyridin, Anilin, Picolin, Lutidin, Collidin, Leukolin, Iridolin, Akridin).
 - (δ) Asphaltic substances (Anthracen, Resins, Coal).
4. Illuminating Gas:
 - (α) Illuminants { Gases: Acetylen, Ethylen, Propylen, Butylen.
Vapors: Benzol, Styrol, Naphthalin, Acetylnaphthalin, Propyl, Butyl.

- (β) Diluting parts (Hydrogen, Methane, Carbon Monoxide).
 (γ) Impurities (Carbon dioxide, Ammonia, Cyanogen, Rhodan, Sulfuretted Hydrogen, Sulfuretted Hydrocarbons, Bisulphide of Carbon, Nitrogen).

The manner in which the distillation proceeds and the quantity and composition of the various products are distinctly affected by other factors than the character of the raw materials. The most important of these factors is the gasifying temperature.

L. T. Wright has distilled at different temperatures a coal of the following composition:

C.....	75.71 per cent,
H ₂	6.27 per cent,
S.....	1.72 per cent,
N.....	1.72 per cent,
O.....	11.59 per cent,
Ash.....	2.99 per cent,

100.00 per cent.

The yield of 100 kg. of coal at a gasifying temperature of 800° C. is given in Table XCII.

TABLE XCII.

ANALYSIS OF DESTRUCTIVE DISTILLATION PRODUCTS.

100 Kg. Coal Yielded.	C	H ₂	S	N	O	Ash.	Total.	Liters.
	Kg.							
Coke.....	57.38	1.24	1.05	1.06	1.28	2.96	64.97
Tar.....	6.11	0.46	0.05	0.06	0.60	7.28	6.43
Gas water.....	0.08	1.06	0.12	0.22	8.30	9.78	9.78
Gas.....	7.56	2.85	trace	0.36	1.46	12.23	21140.0
In purifying mass	0.22	0.02	0.39	0.56	0.56	1.20
Total.....	71.35	5.63	1.61	1.71	12.20	2.96	95.46

The yield obtained at a temperature of 1100° C. is given in Table XCIII.

TABLE XCIII.
ANALYSIS OF DESTRUCTIVE DISTILLATION PRODUCTS.

100 Kg. Coal Yielded.	C	H ₂	S	N	O	Ash.	Total.	Liters.
	Kg.							
Coke.....	57.95	0.70	0.77	0.47	1.24	2.97	64.10
Tar.....	4.78	0.38	0.06	0.05	1.18	6.47	5.37
Gas water.....	0.08	1.06	0.13	0.21	8.30	9.78	9.66
Gas.....	8.53	3.42	trace	0.86	2.30	15.11	31200.0
In purifying mass	0.38	0.04	0.74	0.02	0.93	2.11
Total.....	71.73	5.61	1.70	1.61	13.95	2.97	97.57

	At 800° C.	At 1100° C.
There was further		
Soot in tar.....	15 per cent	25-30 per cent
Specific gravity of gas water.....	1.0	1.2
Illuminating power of gas at an hourly use of 150 liters.....	18 candles	15.3 candles

A further comparison shows:

	At 800° C.	At 1100° C.
Coke.....	64.75 kg.	64.16 kg.
Tar.....	6.43 l.	5.37 l.
Gas water.....	9.78 l.	9.96 l.
Gas.....	21.14 cu. m.	31.20 cu. m.

With increasing temperature the gas quantity (volume), the specific gravity of the tar, and its content of soot, increase, while the crude naphtha and, especially on light tar oil, content of tar considerably decrease.

With increasing temperature the creosote and anthracen oil content decreases, while the pitch content increases. The sulphur content of the gas other than that in the form of H₂S is three times as great at the high as at the low temperature. The ammonia content is small at low temperature, is a maximum at medium and decreases with temperature rise at high temperature.

The course of distillation is different at the beginning and at the end. In the Paris gas plant at a temperature of 1000° C. there is obtained:

Time of distillation, hrs.	0	1	2	3	4	5	6
Volume of gas.....	0	17	30	27	20	6	0
Illum. power per 105 l..	0	1.15	0.90	0.30	0.10	0.4	0

C. G. Miller divides the time of distillation into two periods: In the first — the period of distillation proper — at the comparatively low temperature of 500°–600° C. strongly illuminant gases, steam and tar are generated while the coal is coked. In the second period (bright red glow) the coke, decreasing in volume, yields gases (about one-third of the total gas volume) which are free of tar and of low illuminating power. The coke remaining at the end of the first period is probably a mixture of very stable carbon-compounds having the average composition $C_{15}H_4O$. This substance is further decomposed in the second period at high temperature. But even at the highest practical heat it is impossible to remove the traces of oxygen, hydrogen and nitrogen.

If large quantities of coal are put into highly heated retorts, both processes take place simultaneously. The two, however (coal decomposition and coke decomposition), could be separated by using two furnaces, one for heating the material to 600 degrees and removing the tar, the other to decompose the coke. Such a separation might be practicable under certain conditions. The experiments made by Mueller on a small scale confirm the well-known fact that only one-fifth of the nitrogen of the coal is present in the form of ammonia compounds; further, that the ammonia is formed in the first part of the decomposition of coke. The ammonia yield was

Test.	In the First Period.	In the Second Period.
No. 1	0.065	0.267
2	0.059	0.144
3	0.108	0.145
4	0.120	0.178
5	0.063	0.183
6	0.056	0.242
Average.....	0.0785	0.1931

How the composition of the products changes by using different qualities of gas-coal is shown in Table XCIV.

TABLE XCIV.

CHANGE IN COMPOSITION OF PRODUCTS WITH QUALITY OF COAL.

Bituminous Coal from		Pas de Calais.	Eng-land.	Comen-try.	Blanzy.	
Composition	H ₂ O, hygroscopic.....	2.17	2.70	3.31	4.34	6.17
	Ash.....	9.04	7.06	7.21	8.8	10.73
	O.....	5.56	6.66	7.71	10.10	11.70
	H ₂	5.06	5.36	5.40	5.53	5.64
	C.....	88.38	86.97	85.89	83.37	81.66
	N.....	1	1	1	1	1
Products of Dis-tillation	Gas.....	13.70	15.08	15.81	16.95	17
	Tar.....	3.90	4.65	5.08	5.48	5.59
	Ammonia water.....	4.59	5.57	6.80	8.61	9.86
	Coke.....	71.48	57.63	64.90	60.88	58
	Coal dust.....	6.33	7.07	7.41	8.08	9.36
Gas (Volume)	{ Volume, cu. m.....	30.13	31.01	30.64	29.73	27.44
	{ Illuminating power, Carcell.....	131c	112c	104c	102.1c	101.8c
	{ CO ₂	1.47	1.58	1.72	2.79	3.13
	{ CO.....	6.68	7.17	8.21	9.86	11.93
	{ H ₂	54.21	52.79	50.10	45.45	42.26
	{ CH ₄	34.37	34.43	35.03	36.42	37.14
	{ C ₆ H ₆	0.79	0.99	0.96	1.04	0.88
	{ C ₂ H ₄	2.48	3.02	3.98	4.44	4.76

The influence of the mineral substances on the course of distillation is remarkable, as is seen from Knoblauch's researches. He mixed with his coal 2.5, 5, and 10 per cent of lime, and 5 per cent silica respectively. The table on following page shows the differences of yield with these mixtures (from 1000 kg. of coal).

We see that the quantity of products of distillation is not changing in proportion to the quantity of the addition. The gas yield, however, seems to be an exception, as it increases in proportion to the addition. The yield in ammonia increases very slowly as the lime is added, so that with a certain quantity of lime a maximum is reached, above which even a large addition of lime has no effect. There is no relation between silica and ammonia and H₂S, since no reaction takes place. The small differences shown in the above table are caused by variations in

the decomposition of the coal, since the quantity of coke increases with additions more rapidly than the quantity of tar decreases, and since at the same time gas quantity increases the carbon content and therefore the illuminating power of the gas is necessarily decreased, which decrease is not sufficiently counterbalanced by the increased yield of gas.

TABLE XCV.

EFFECT OF ADMIXTURE OF LIME AND SILICA IN DISTILLATION PRODUCTS.

1000 Kg. Coal.	Addition of Lime.			Addition of Silica, 5 Per cent.
	2.5 Per cent.	5 Per cent.	10 Per cent.	
Gas, cu. m. increase.....	14.7	20.1	35.3	21.5
Coke, kg. increase.....	16.8	18.2	17.5	27.4
Tar, kg. decrease.....	5.2	7.9	9.0	11.8
Ammonia, kg. increase.....	0.483	0.608	0.929	0.15
Sulphate, kg. increase.....	2.02	2.53	3.88	0.67
H ₂ S, kg. decrease.....	1.42	1.58	1.81	0.21
H ₂ S, cu. m., decrease.....	0.93	1.03	1.19	0.138
Ammonia } in per cent { increase	21.3	26.7	40.9	0.7
H ₂ S..... } of yield { decrease	59.7	66.2	76.2	8.8

For coals of approximately the same composition as the test-coal we can estimate the effect of adding 2.5 per cent of lime as follows:

1. The yield of gas is increased 5 per cent, the illuminating power decreased 5 per cent.

2. The yield of coke is 4 per cent higher, of which 2.5 per cent is lime, so that the actual increase of coke-output is 1.5 per cent. This increase is not accompanied by an increase in thermal value, on account of the higher ash content.

3. The quantity of tar is decreased 10 per cent and its quality deteriorated.

4. The ammonia output is increased 20 per cent.

5. The H₂S output is decreased at the rate of 1.4 per 1000 kg. coal.

6. The CO₂ of the crude gas is increased 10 per cent.

7. The formation of cyan is somewhat decreased, but the quantity of ferrocyan is not changed.

This point, however, and also the question as to what extent the higher sulphur content of the coke (in the above case about 0.2 per cent) appears as combustible sulphur, have to be further considered.

W. Jicinski made experiments with Moravian (Austria) coal from Ostrau of 5 mines; the composition is given in Table XCV, and the yield from destructive distillation is given in Table XCVI.

TABLE XCV.

COMPOSITION OF MORAVIAN COALS. (Jicinski.)

Air-dried Coal from	Percentage of					Coking Quality.	Quality.
	C	H	O	N	Ash.		
Johann.....	81.74	5.53	6.18	1.31	5.24	Good	Gas coal
Adolf.....	81.80	5.23	8.31	1.76	2.89	Very good	Gas coal
Günther...	80.54	5.09	7.66	1.43	5.27	Very good	Coking coal
Franziska..	83.35	4.66	5.06	1.52	5.37	Excellent	Coking coal
Juliana....	86.76	4.06	3.51	1.30	4.73	Fair	Anthracite coal

S Content: 0.50 to 1.05 per cent. *P* Content: 0.004 to 0.108 per cent.

TABLE XCVI.

YIELD FROM DESTRUCTIVE DISTILLATION OF COALS GIVEN IN TABLE XCV.

Mine.	Per 1 Kg. of Coal Cu. M. of Gas.	Coke Residuum. Per Cent.
Johann.....	30.86	67.00
Adolf.....	30.02	76.00
Günther.....	29.96	75.00
Franziska.....	28.60	81.38
Juliana.....	27.12	86.62

The ammonia output is not in proportion to the nitrogen content of the coal. Ammonia seems to separate from some coals easier than from others. As an average about 0.75 of the total nitrogen of the coal remains in the coke; this is the so-called

coal-nitrogen, which is only gasified by the complete combustion of the coal. About 0.25 of the total nitrogen — the ammonia nitrogen — takes part in the formation of ammonia. But even from this, one part escapes as cyan or as free nitrogen, so that the quantity of nitrogen actually available for the ammonia formation is only 0.188 to 0.089 of the total nitrogen. The table below shows the available quantity of ammonia nitrogen in some coals.

The tar from coke ovens contains generally

Benzene	0.9 –1.06 per cent,
Naphthalene	4.26–5.27 per cent,
Anthracen	0.57–0.64 per cent,
Pitch	50 per cent,
Other residuum	40 per cent.

TABLE XCVII.

AVAILABLE QUANTITY OF AMMONIA IN COALS.

Mine.	Total N in Per Cent of Air-Dry Coal.	Available for NH ₃ .		NH ₃ in Per Cent of Coal.	Calculated as Sulphate.	Available Tar in Per Cent.
		Of Total N.	In Per Cent of Coal.			
Kaiserstuhl } Pluto } Wilhelmine } Westphalia	1.39	0.144	0.200	0.244	0.94	} 3.4
	1.45	0.146	0.212	0.258	1.00	
	1.77	0.142	0.252	0.306	1.18	
Johann } Adolf } Günther } Franziska } Juliana } Austria	1.31	0.140	0.184	0.244	0.94	1.7
	1.76	0.126	0.222	0.270	1.04	1.7
	1.43	0.120	0.172	0.210	0.81	1.3
	1.52	0.089	0.135	0.165	0.64	2.6
	1.30	0.134	0.175	0.213	0.82	1.8
Upper Silesia, average	2.49	0.188	0.296	0.360	1.40	3.6
Friedenshoffnung } Karl, Georg } und Viktor } Lower Silesia	Un-known	Un-known	0.168	0.204	0.79	3.0
	1.40	0.167	0.235	0.286	1.11	3.12
England, average	1.40	0.167	0.235	0.286	1.11	3.12

The average tar output on a large scale is from 2 to 3 per cent of the coal. The difference between coke oven gas and gas house gas is given in Table XCVIII.

TABLE XCVIII.
ANALYSIS OF COKE OVEN AND ILLUMINATING GAS.

Components.	Coke Oven Gas. Per Cent.	From Gas House Per Cent.
Benzole vapor.....	0.61	1.54
Ethylene.....	1.63	1.19
H ₂ S.....	0.43
CO ₂	1.41	0.87
CO.....	6.49	5.40
H ₂	53.32	55.00
CH ₄	36.11	36.00
Sum.....	100.00	100.00

The experiments relative to the yield of carbonizing (coking) peat made by Sir Robert Kane and Professor Sullivan have given the following results:

TABLE XCIX.
ANALYSIS OF COKE OVEN GAS.

Products Obtained by Coking.	From an Oven at Seraing (Ebelmen).				From Gas-forth Coal (Bunsen).	From Alfreton Coal, Distilled (Bunsen).	
	2	7½	14	Average.		Forward.	Backward.
	Hours after Starting.						
Methane.....	1.44	1.66	0.40	1.17	7.0	6.6	6.2
Carbon monoxide.....	4.17	3.91	2.19	3.42	1.1	1.6	6.3
Carbon dioxide.....	10.13	9.60	13.06	10.93	1.1	1.1	2.3
Olefine gas.....	0.7	0.5	1.6
H ₂ S.....	0.5	0.2	0.2
H ₂	6.28	3.67	1.10	3.68	0.5	0.4	1.4
NH ₃	0.2	0.2	0.3
N.....	77.98	81.16	83.25	80.80	0.03
H ₂ O.....	7.5	12.4
Tar.....	12.23	9.7	16.6
Coke.....	68.92	67.2	65.1
Volatile components.....	30.8	to 32.	7%
Combustible gases.....	19.2	to 22.	3%

100 pounds of peat of different quality was coked in retorts similar to illuminating gas retorts. The volatile matters were

condensed in a number of Woulf-bottles and in a cooled coil. The gases were also collected (Table C).

TABLE C.
PRODUCTS OF PEAT DISTILLATION.

Origin.	Water.	Tar.	Coal.	Gas.
Light peat Dense peat	23.600	2.000	37.500	36.900
Even mixture of light and heavy peat of Mount Lucas Bog near Phillipstown.				
Light peat from Wood of Allen	32.273	3.577	39.132	25.018
Heavy peat from Wood of Allen . . .	38.102	2.767	32.642	26.489
Upper layer of Ticknevin	38.628	2.916	31.110	32.346
Upper layer of Ticknevin, distilled at red glow	32.098	2.344	23.437	42.121
Upper layer of Shannon	38.127	4.417	21.873	35.693
Dense peat	21.189	1.462	18.973	57.746
Average	31.378	2.787	29.222	36.606

TABLE CI.
PRODUCTS FROM DISTILLATION OF PEAT.

Origin.	Tar Water.					Tar.		
	Ammonia.		Acetic Acid		Wood Alcohol.	Paraffin.	Fuel Oil.	Lubricating Oil.
	NH ₃ .	(NH ₄) ₂ SO ₄ .	C ₂ H ₄ O ₂ .	Acetate of Lime.				
Light peat Dense peat	0.302	1.171	0.076	0.111	0.092	0.024	0.684	0.469
Even mixtures of light and heavy peat of Mount Lucas Bog, near Phillipstown								
Light peat from Wood of Allen	0.187	0.725	0.206	0.302	0.171	0.179	0.721	0.760
Heavy peat from Wood of Allen	0.393	1.524	0.286	0.419	0.197	0.075	0.571	0.565
Upper layer of Ticknevin	0.210	0.814	0.196	0.287	0.147	0.170	0.262	0.617
Upper layer of Ticknevin, distilled at red glow	0.195	0.756	0.208	0.305	0.161	0.196	0.816	0.493
Upper layer of Shannon	0.404	1.576	0.205	0.299	0.132	0.181	0.829	0.680
Dense peat	0.181	0.702	0.161	0.236	0.119	0.112	0.647	0.266
Average	0.268	1.037	0.191	0.280	0.146	0.134	0.790	0.550

The analysis of the tar water and tar showed for the qualities given in Table CI.

Table CII gives the results of another series of experiments in which a part of the peat was burned by means of a blower.

TABLE CII.
PEAT DISTILLATION.

Origin.	Water.	Tar.	Ash.	Gases.
Light peat from Wood of Allen	30.678	2.510	2.493	63.319
Heavy peat from Wood of Allen . . .	30.663	2.395	7.226	59.716
Upper layer of Shannon	29.818	2.270	2.871	65.041

For further comparison the figures given in Table CIII, taken from both series of experiments, will be interesting:

TABLE CIII.
PEAT DISTILLATION.

Origin.	Tar Water.			Tar.	
	NH ₃ .	Acetic Acid.	Alcohol CH ₄ O	Paraffin.	Oil.
Light peat from Wood of Allen	0.322	0.179	0.158	0.169	1.220
Heavy peat from Wood of Allen	0.344	0.268	0.156	0.086	0.946
Upper layer of Shannon	0.194	0.174	0.106	0.119	1.012
Average	0.287	0.207	0.140	0.125	1.059

These tables also give an idea of the valuable products obtained by distilling peat. Table CIV from Muspratt's Chemistry gives the yields from Irish peat.

TABLE CIV.
DESTRUCTIVE DISTILLATION OF PEAT.

Products of Destructive Distillation.	In Closed Vessels.	With Admission of Air.
Ammonia	0.268	0.287
or sulphate of ammonia	1.037	1.110
Acetic acid	0.192	0.207
or acetate of lime	0.280	0.305
Wood alcohol	0.146	0.140
Oils	1.340	1.059
Paraffin	0.134	0.125

TABLE CV.
DESTRUCTIVE DISTILLATION OF PEAT.

Yield in Per Cent.	Kane and Sullivan, Per Cent.	Hodges, Per Cent.	Prospectus of Irish Peat Company, Per Cent.
Sulphate of ammonia.....	1.110	1.000	1.000
Acetic acid.....	0.207	0.328
or acetate of lime.....	0.305	0.700
Wood alcohol.....	0.140	0.232	0.185
Tar.....	2.390	4.440
Paraffin.....	0.125	0.104
Oils.....	1.059	0.701

The average composition of perfectly dry peat-coal is

C.....	75 to 85 per cent
H ₂	2 to 4 per cent
O.....	10 to 15 per cent
Ash.....	5 to 10 per cent.

The per cent of ash can be as high or higher than 60 per cent. Air-dry peat-coal contains at least 10 per cent of hygroscopic water. The sulphur and phosphorus content of the ash is sometimes considerable.

TABLE CVI.
DESTRUCTIVE DISTILLATION OF PEAT.

Products of Distillation.	Peat from Neumarkt (Wagenmann.)		Peat from Oldenburg, (Vohl).
	A.	B.	
Per Cent.			
Water in peat.....	33.58	36.26	air dry
Ash in peat.....	6.76	5.49
Coke.....	27.70	25.77	35.3120
Ammonia water.....	50.01	58.03	40.0000
Ammonia in same.....	0.32	0.25
light oil.....	0.435	0.380	1.7633*
heavy oil.....	1.103	1.124	1.7715
paraffin matter.....	1.943	2.389
asphalt.....	1.5582
paraffin.....	0.3005
creosote.....	3.6695
carbonaceous residuum.....	1.105	0.663
loss.....	0.304	0.634
Gases.....	15.6250
Vapors.....
Total.....	100.32	100.10	100.0000

* This tar-output is, according to Stohmann, entirely too high, probably on account of some water being present.



Peat-coal is very porous and light, has a specific gravity of 0.23 to 0.38, absorbs dyes and odoriferous substances, and is therefore used for removing fusel oil from brandy, as disinfectant, and as fertilizer.

It is easily ignited and continues to burn even with very weak draught. The calorific value varies from 6500 to 7000 cal.

Brown coal (lignite) coke. Earthy brown coal disintegrates in the heat and therefore cannot be coked. Of this class of fuels lignite and pitch coal are almost the only ones that can be used for this purpose, and lignite furnishes a coke similar to charcoal. The destructive distillation of lignite yields

40 to 50 per cent.....	Coke
12 to 20 per cent.....	Tar water
14 to 35 per cent.....	Tar
12 to 25 per cent.....	Gases.

Coke from bituminous coal is generally dark gray, sometimes silver gray, light gray or black. The light coke is melted, the dark generally baked.

Coke-oven coke is generally less dense than gas-retort coke, which explains the advantage of the former in metallurgical operations and firing. According to Muck the specific gravity varies from 1.2 to 1.9.

In practice the strength and composition of the coke is of importance, the former for blast furnaces on account of the great weight of the charge, the latter on account of deleterious effects of certain substances.

Director Jugnet has found the following data relating to strength of coke:

Carve's oven 70 cm.....	66.4 kg. per sq. cm.
Carve's oven 66 cm.....	79.72 kg. per sq. cm.
Carve's oven 50 cm.....	92.32 kg. per sq. cm.
Beehive oven 50 cm.....	43.92 kg. per sq. cm.
Smet oven 50 cm.....	42.12 kg. per sq. cm.
Coppée oven 50 cm.....	80.50 kg. per sq. cm.

Relative to the composition, the quantity of sulphur and phosphor is of technical importance.

Coke is hard to ignite, burns with a short, blue flame, and

requires a strong air draught. The calorific value is from 7000 to 7800 cal.

A hair-like formation, called coke-hair, is sometimes formed on the surface of the coke. This coke-hair is free of ash and is the coked residuum of tarry products of distillation. The composition (dried at 110° C.), according to V. Platz, is

C.	95.729 per cent
H ₂	0.384 per cent
O.....	3.887 per cent
Ash.....
	100.000 per cent

We will now discuss in a few words pressed coal, or briquettes. In order to utilize the culm coal it has been attempted (with or without suitable binding materials) to combine the small pieces into larger pieces called briquettes, and we have:

Peat briquettes or *pressed peat*, which is made and used in the vicinity of peat deposits.

Soft coal briquettes, in which tar, pitch, asphalt, starch, molasses, clay, gypsum, alum, lime or soluble glass, etc., is used as binder. The coal dust is mixed with the binder and pressed into bricks. They have frequently the disadvantage of developing smoke of disagreeable odor or containing too much ash.

Charcoal or *coke briquettes* are made in the same way.

Lignite briquettes. Here the resinous and other organic matters of the coal serve as a binder. The coals are dried until they contain about 15 per cent of water and are then pressed hot (at 1000–1500 atm. pressure). The content of water is necessary for preventing the decomposition of the organic substances. The manufacture of such lignite is steadily increasing in Germany and Austria. In 1901 120,000 carloads of briquettes were sold for domestic use in Berlin, and only 5000 carloads of soft coal.

The combustion of these briquettes is peculiar, as for a good utilization of the fuel a very weak draught has to be used, whereby the lignite is burned very slowly, giving most of its heat off to the stove. With a strong draught the briquettes are burned quickly, and the largest part of the heat is lost through the chimney.

The analysis given in Table CVII is taken from the *Zeitschrift des Vereines deutscher Ingenieure* (1887, page 91).

TABLE CVII.
COMPOSITION OF LIGNITE BRIQUETTES.

	1	2	3	4
Ash.....	5.83	5.59	5.93	5.95
Water.....	19.81	18.67	21.10	22.46
Volatile matter.....	24.53	24.93	28.52	16.74
Fixed carbon.....	48.83	50.79	44.83	54.74
Calorific value.....	3203 Cal.	3215 Cal.	3159 Cal.	2784 Cal.

I and II are good, III and IV inferior briquettes. Briquettes from Schallthal (Styria) contain:

C.....	48.21 per cent,
H ₂	3.99 per cent,
O.....	19.92 per cent,
S.....	1.35 per cent,
H ₂ O (hygroscopic).....	15.63 per cent,
Ash.....	10.91 per cent.
Thermal value.....	4280 cal.

The analysis of the so-called Clara briquettes shows:

Elementary analysis:

C.....	48.72 per cent,
H ₂	5.80 per cent,
O and N.....	22.93 per cent,
Ash.....	12.62 per cent,
H ₂ O (hygroscopic).....	10.93 per cent.

Intermediate analysis:

H ₂ O (hygroscopic).....	10.93 per cent,
Volatile matters.....	44.21 per cent,
Fixed carbon.....	32.24 per cent,
Ash.....	12.62 per cent.
Calorific value (determined in calorimeter).....	4656 cal.
Effective thermal value (H ₂ O formed calculated as steam).....	4349 cal.
Calorific value of the coal free of ash and H ₂ O.....	5688 cal.

CHAPTER XVII.

COKING APPARATUS.

THE apparatus for manufacturing coke (and peat-coal) from raw fuels can be classified as follows:

A. Coking in piles.

- (α) The piles are built with coal lumps exclusively and covered with earth. The pile has a shaft opening in the center and draught holes (Fig. 58).
- (β) The pile has a brick shaft in the center (Fig. 59).
- (γ) A channel on the bottom of the pile and a movable piston in the shaft serves for saving the products of distillation: Dudley's coke pile.

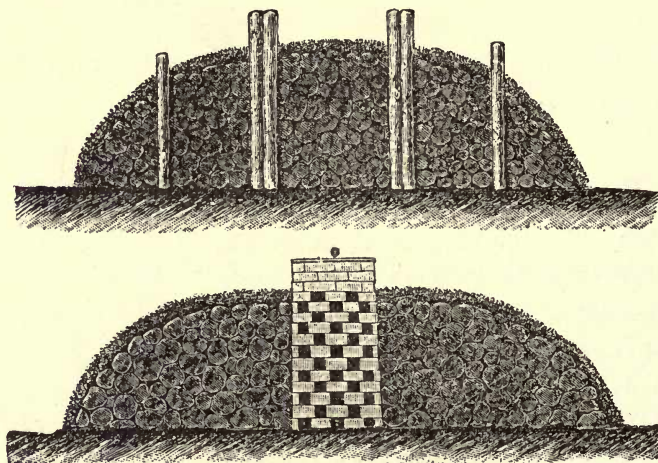

FIGS. 58 and 59. — Coke Piles.

B. In heaps.

- (α) Analogous to the heaps used for charring wood.
- (β) Heaps temporarily surrounded with boards (like Foucault's charring system). The heaps are made either rectangular or circular.

C. In closed piles (kilns) with brick walls on the sides. Generally rectangular and provided with charging doors in the center of both short sides. Vertical and horizontal air channels, which

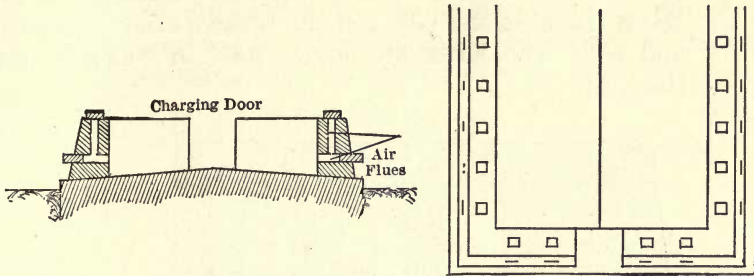

FIGS. 60 and 61. — Closed Piles (for coking).

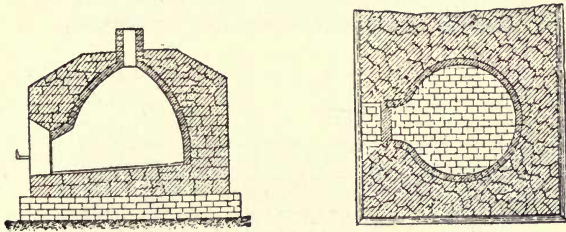

FIGS. 62 and 63. — Riesa Oven.

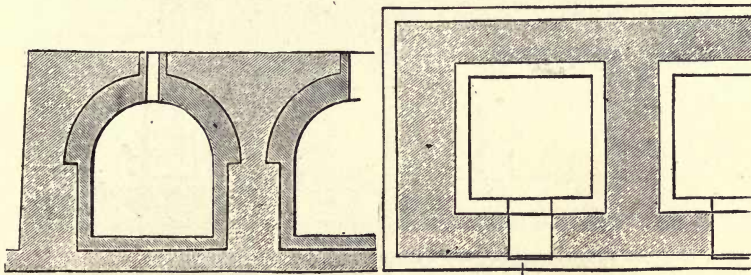

FIGS. 64 and 65. — Bee Hive Oven.

can be partly or entirely closed with bricks, etc., transverse the walls and serve for regulating the air admitted. The pile is covered with coke culm (Figs. 60 and 61). The Schaumburger coke ovens belong to this class.

D. Coking in closed ovens.

(a) Ovens with admission of air to the interior, the heat for coking being furnished by partly burning the coal to be coked. To this class belong the older construction of Riesa (Figs. 62 and 63), and the beehive ovens (Figs. 64 and 65). The latter are largely used in America and England.

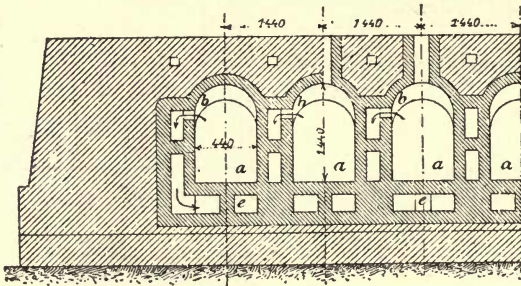

FIG. 66. — Section of Francois-Rexroth Coke Oven.

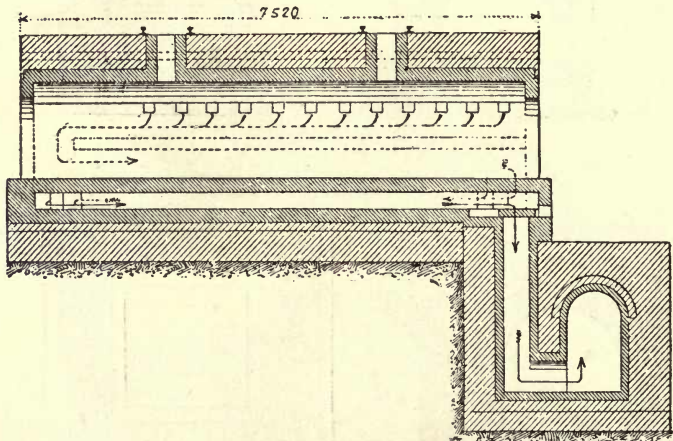

FIG. 67. — Section of Francois-Rexroth Coke Oven.

The composition of the gases from these ovens was given in the last chapter (Table XCIX). Since these gases contain a large amount of combustible matter at a high temperature, their utilization for heating purposes was suggested. This purpose is frequently accomplished (in connection with the beehive type) by heating boilers with the gases; in this case the boilers are

built on top of the oven. Some of the other methods of utilizing this heat are:

(b) Coke ovens without admission of air to the interior, which are heated by the gases generated during the coking process. The coking is performed in chambers of prismatic form, which are classified as

(α) Horizontal ovens:

1. Without condensing plant for the gas.
2. With condensing plant for the gas.

(β) Vertical ovens:

1. Without condensing plant for the gas.
2. With condensing plant for the gas.

(γ) With inclined axis (system Powel and Dubochet) has not come into practical use.

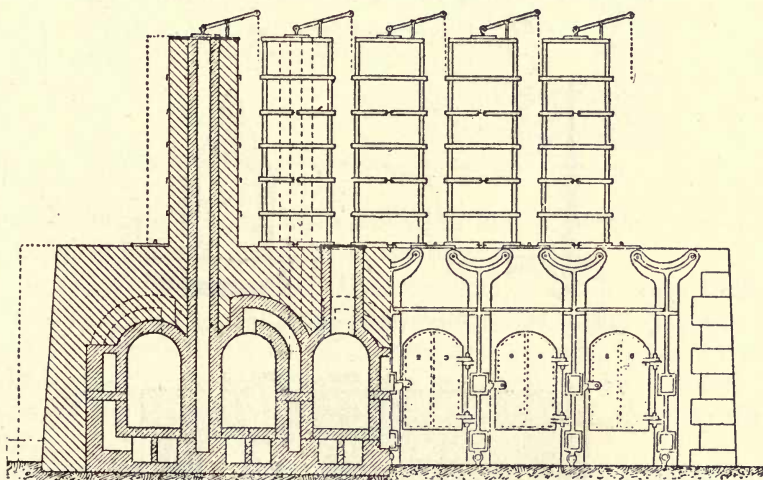

FIG. 68. — Coke Oven, System Smet (elevation).

The horizontal ovens are constructed in different styles according to the path of the gas through the furnace. The most important types are:

François-Rexroth coke oven (Fig. 66 cross-section, Fig. 67 longitudinal section through chamber).

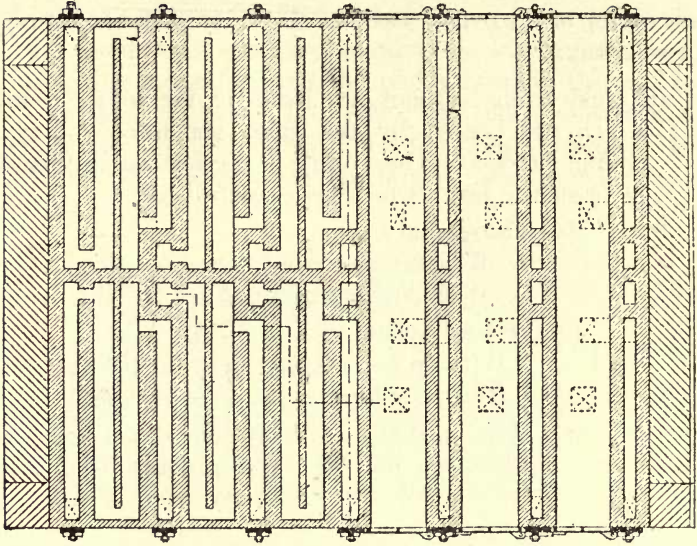
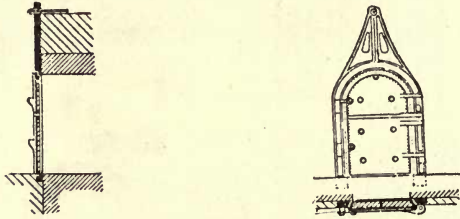

FIG. 69. — Coke Oven, System Smet (plan).



FIGS. 70 and 71. — Coke Oven, System Smet (details of doors).

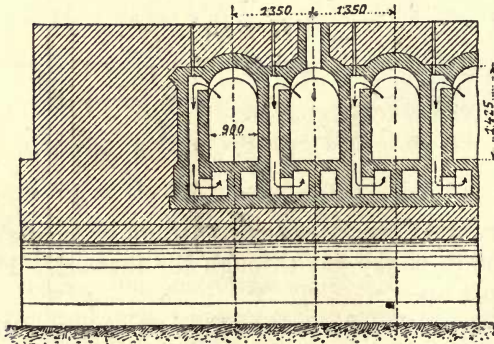

FIG. 72. — Coke Oven, Francois (cross-section).

The gases leave the chambers at the sides, pass through two horizontal channels (in the side walls) then through two horizontal channels in the bottom into the flue.

Smet coke oven (Fig. 68, front view and section; Fig. 69, section through chambers and channels in the bottom; Figs. 70, 71, details of doors).

The gases go as in the previous type through horizontal chan-

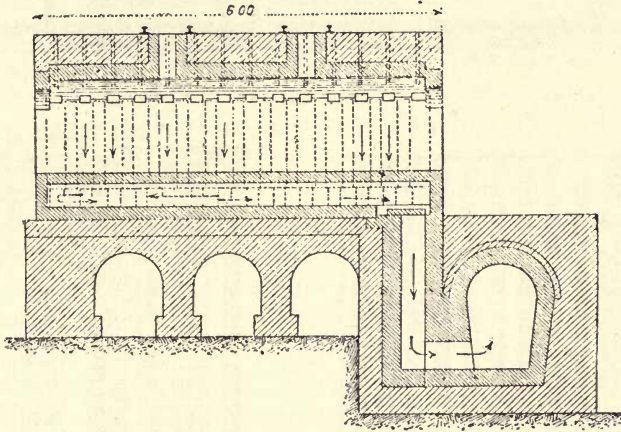

FIG. 73. — Coke Oven, François (longitudinal section).

nels near one of the side-walls and under the floor of the chamber. The gases leave the chamber at the highest point.

François coke oven (Fig. 72, cross-section; Fig. 73, longitudinal section). The gases of distillation leave at the side, the same as in the François-Rexroth system; the gases are carried parallel to the wall of the chamber in vertical channels downward, under the floor of the chamber (however, in horizontal channels) into the flue.

Similar are the systems of Coppée (Figs. 74, 75, 76, 77, and 78), and Dr. Otto. The main difference between these and the former types is the greater height, and length and smaller width of the chambers, whereby an increase in the heating surface is effected.

Vertical coke ovens without condensation belong to the oldest types (Appolt system, 1854). They have an exceedingly large heating surface and were at one time held in high esteem. They are, however, very much more expensive to build and

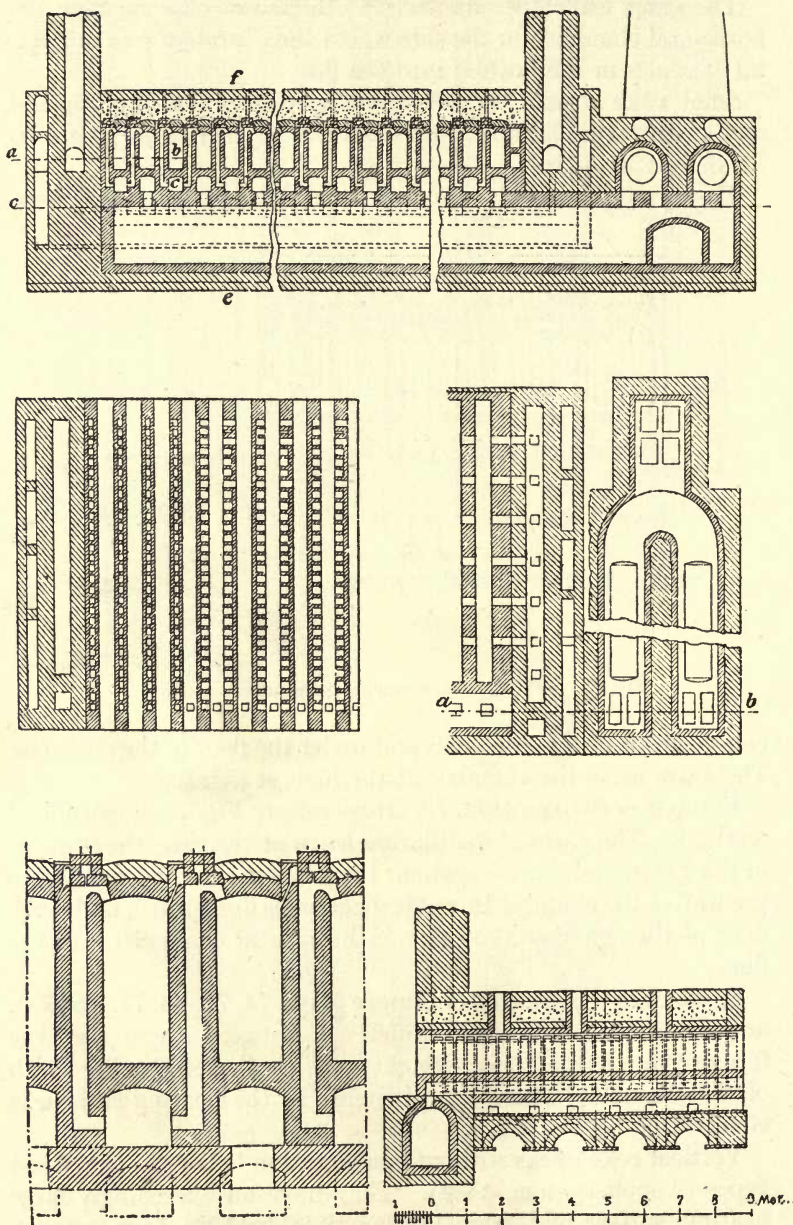

Figs. 74-78. — Coppée's Coke Oven.

operate than the horizontal ovens, so that they are only of historical interest.

In the destructive distillation of coal, besides coke, a number of by-products, as tar, gas water, etc., are obtained, the recovery of which in many cases is desirable on account of their content of valuable substances (ammonia, benzol, etc.), notwithstanding the loss of heat by cooling and the decrease in calorific value by removal of the products of condensation.

As the by-product recovery in the coke industry is coming more and more into use, we want to show the changes in oven construction caused by the introduction of this process, taking as an example the bottom-fire oven of Dr. Otto (Figs. 79, 80, 81).

The gases pass up through two pipes provided with valves and connected to the highest point of every chamber into the receivers *a*, which extend across the entire battery of ovens, analogous to the hydraulic main in a gas plant. In the receiver a part of the tar is condensed, and the gas goes through condensing and purifying apparatus, from here returning to the ovens. It passes through gas pipes *b* (one for every two ovens) to the burners of the combustion chambers. The air of combustion enters around every burner. The combustion gases go through the center of the combustion chamber downward, through slots into a side flue (below every coking chamber), which conducts to the main flue.

In the more modern ovens the combustion air is preheated in regenerators before entering the ovens.

The coke obtained in such an oven is removed red hot and cooled with water, for preventing combustion in the atmosphere.

For making peat-coal (coke) we have, besides the above apparatus,

E. Ovens heated exclusively from outside:

(*a*) With a special fireplace (Lottmann's oven; Crony retort oven).

(*b*) With superheated steam (Vignoles' oven).

(*c*) With combustion gases Crane's oven, using solid or gaseous fuel.

Finally we want to say a few words about coking of lignite (brown coal), which is carried on mainly in Saxony and Thuringia, where coals rich in paraffin are mined. Rolle's plate oven is almost exclusively used for this purpose. Such an oven can coke

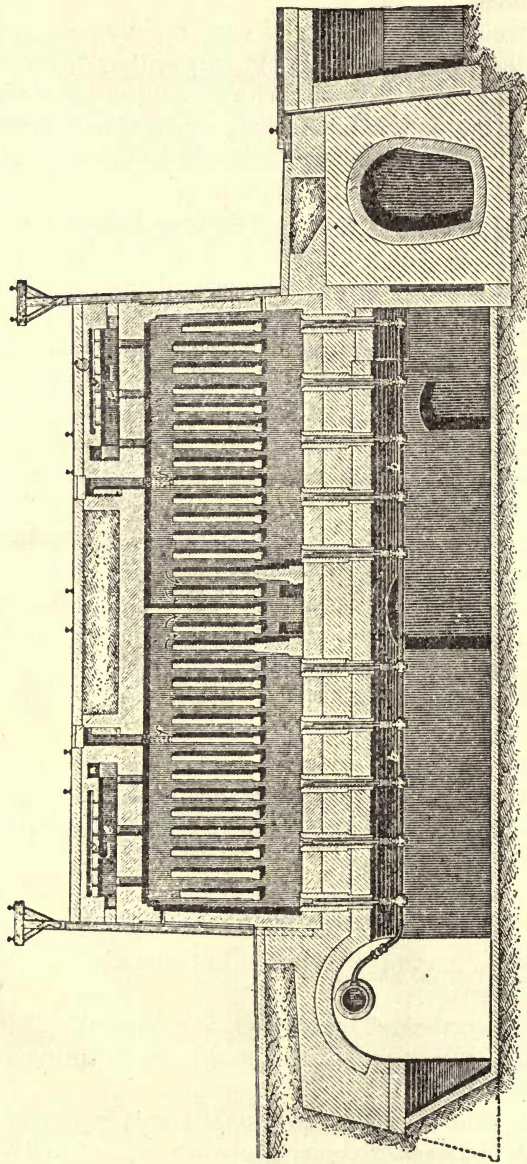
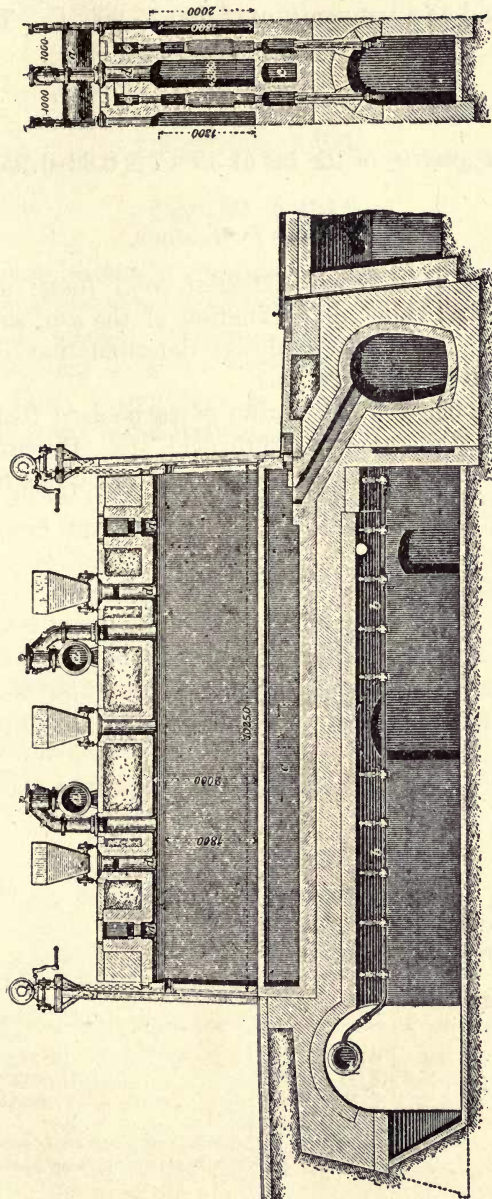

Fig. 79. — Dr. Otto's Coke Oven.



Figs. 80 and 81. — Dr. Otto's Coke Oven.

2500 kg. of lignite in 24 hours, with a coal consumption of 25 to 30 per cent and at a temperature of 800 to 900° C. The yield is

Tar.....	10 per cent,
Water.....	50 per cent,
Coke.....	32 per cent.

The specific gravity of the tar at 35° C. is 0.82–0.95.

Suggestions for Lessons.

Examination of different artificial solid fuels; elementary analysis, calorific value, determination of the ash, sulphur and phosphorus content, ash analysis; determination of specific gravity, strength and porosity.

Yield by destructive distillation of carbonized fuel, gas, tar and tar water, also ammonia, acetic acid, etc. Herein the influence of the temperature of distillation, slow or quick heating, of admixtures, etc., has to be studied.

CHAPTER XVIII.

LIQUID FUELS.

To this class belong oil (petroleum), tar from destructive distillation of coal and wood, schist-oil, and to a small extent certain vegetable oils, alcohol, turpentine, benzine, etc.

The liquid fuels have the advantage of burning up without residuum. Such a residuum as remains of solid fuels might obstruct the grate, cause uneven air supply and incomplete combustion.

The utilization however, of liquid fuels presents some serious difficulties and makes the construction of well designed and carefully tested burners imperative. The main difficulty is the atomization, otherwise carbon is deposited, which will cause stoppages and block the flow of the liquid.

A general use of liquid fuel is prevented by high cost. However, under certain local conditions it can be used economically.

The experiments for introducing alcohol as fuel on a large scale have so far not been successful.

Table CVIII contains some data relating to the use of liquid fuels.

TABLE CVIII.
COMPOSITION OF LIQUID FUELS.

Kind of Fuel.	Composition in Per cent.				Calorific Value in Kg-cal.
	C.	H.	O.	Ash.	
American crude oil	83.0	14.0	3.0	11100
Caucasian crude oil	85.0	11.5	3.5	10300
Refined American oil.....	85.5	14.2	0.3	11046
Coal tar	90.0	5.0	5.0	8900
Heavy oil from American petroleum	87.0	13.0	10900
Heavy oil from Caucasian petroleum	86.7	13.0	0.3	10805
Schist oil	8830
Tar oil	8830
Rape oil.....	77.2	11.7	11.1	9620

The source of oxygen in petroleum is dissolved water; in coal tar the oxygen is partly chemically combined, partly from water.

TABLE CIX.
COMPOSITION OF LIQUID FUELS.

Liquid Fuel.	Burnt to	Calorific Value in Kg-cal. per	
		1 Kg.	1 Mol.
Benzole.....	CO ₂ and H ₂ O liquid	9997	779800
Hexane.....	“ “ “ “	11525	991200
Hexane.....	“ “ “ vapor	10636	914800
Heptane.....	“ “ “ liquid	11375	1137500
Alcohol.....	“ “ “ “	7054	324500
Glycerine.....	“ “ “ “	4316	397100
Butter.....	“ “ “ “	9231
Animal fat average.....	“ “ “ “	9500

The residuum of the first distillation of crude oil is sold in Russia under the name of Masut. When heated to 150 degrees it generates combustible gases, can be ignited at 215 degrees, ignites itself at 300 degrees, and its specific gravity is 0.91. The calorific value is 11,000 cal. In practice 62 kg. Masut replace 100 kg. good bituminous coal. 1000 liters of air are necessary to burn 1 kg. Masut completely.

Table CX shows comparative data (Wright) which, however, change according to the construction of the fire-place.

TABLE CX.
THERMAL EFFICIENCY OF FUELS.

	Calculated Evaporation, Lb. English.	Actual Evaporation, Lb. English.	Thermal Efficiency, Per Cent.
Nottingham cannel coal.....	12.27	8.78	71.56
Gas coal.....	14.24	10.01	70.30
Cannel coal.....	12.23	9.91	81.03
Gas-house coke.....	13.83	11.15	80.62
Tar.....	15.06	12.71	84.40
Creosote.....	16.78	13.35	79.56

CHAPTER XIX.

GASEOUS FUELS.

THE gaseous fuels have, like the liquid fuels, the advantages of burning up without residue, of easy transportation to the place of combustion, and of convenient regulation of temperature. Furthermore, the length of the flame can be varied within certain limits, and for complete combustion a considerably smaller excess of air is required than with solid and liquid fuels. The gaseous fuels, therefore, have a higher temperature of combustion, and generate a smaller quantity of gaseous products of combustion than other fuels of the same composition, whereby a better utilization of the generated heat can be secured. Another advantage is that in this case not only the air for combustion but also the gas can be preheated.

Such gaseous fuel occurs in nature and is then called natural gas. The average composition of Pennsylvania natural gas is

Methane.....	67	per cent,
Hydrogen.....	22	per cent,
Nitrogen.....	3	per cent,
Ethane.....	5	per cent,
Ethylene.....	1	per cent,
Carbon dioxide.....	0.6	per cent,
Carbon monoxide.....	0.6	per cent.

As the occurrence of natural gas is limited, similar gases are artificially produced for industrial use by the following methods:

1. Dry distillation of substances containing carbon, as coal, lignite, peat, wood, fat, etc., whereby gases of distillation (illuminating gas) are obtained. According to the raw material used the manufactured gas is called coal gas, peat gas, wood gas, fat gas, oil gas, etc.

2. Incomplete combustion of coal with insufficient amount of air, whereby generator gas, also called producer gas or air gas, is obtained.

3. Decomposition of water (steam) by glowing coal or combustion of coal by means of steam, whereby water gas is obtained.

In special cases other methods are used for producing fuel gases, as for instance:

4. Incomplete combustion of coal by simultaneous action of air and oxides, the latter thereby being reduced. This reaction takes place in iron blast furnaces and furnishes a gas of high fuel value, low in nitrogen and high in carbon monoxide, which is called blast-furnace gas. If water is used as oxide, semi-water gas or Dowson gas is obtained.

5. For getting high temperatures or high luminant power, acetylene C_2H_2 is sometimes used, which is obtained by reaction of calcium carbide and water:

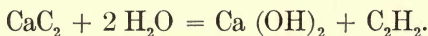

We therefore have the following summary of methods for the

PRODUCTION OF FUEL GASES.

1. By dry distillation:

From coal, coal gas,

From peat, peat gas,

From wood, wood gas,

From fat, fat gas,

From oil residue, oil gas.

2. By incomplete combustion of coal:

(a) With air alone, producer gas (air gas).

(b) With air and oxides of metals Fe_2O_3 , etc., blast-furnace gas.

(c) Air and steam, Dowson gas.

(d) Air and carbon dioxide, regenerated combustion gases.

3. By decomposing carbides with water:

Mainly calcium carbide, acetylene.

Leaving aside the acetylene and the blast-furnace gas, which are only of local importance, the following industrial gases have to be mainly considered:

(1) Gases of distillation, obtained by dry distillation of carbonaceous substances.

(a) Illuminating gas made in retorts. It is used for illuminating, heating and for internal combustion engines.

As an example, the composition of French illuminating gas is given below, which is identical all over France:

Weight of cubic meter = 0.523 kg.

Thermal value of 1 cubic meter = 5600 cal.

Weight of 22.42 liters = 2 grams.

Thermal value of 2 grams = 125 cal.

Analysis in per cent by weight:

Carbon, 43.2 per cent,

Hydrogen, 21.3 per cent,

Oxygen and nitrogen, 25.5 per cent.

Analysis in per cent by volume:

51.0 per cent H_2

33.0 per cent CH_4

8.8 per cent CO

1.8 per cent CO_2

1.0 per cent $O_2 + N_2$

1.1 per cent C_6H_6

3.3 per cent absorbable C_nH_{2n}

100.0

(b) Gases of distillation, produced as by-product in the coking or charring of fuels, mainly coke-oven gas.

(2) Generator gas, air gas, or producer gas is properly the name of such gas only, which is made from carbon (charcoal or coke); i.e., from a coal free from hydrogen and oxygen, and using dry air for the incomplete combustion. In practice, however, we comprise under the classification "generator gas" any gas generated in certain apparatus (gas producers) by leading air without steam through a glowing layer of fuel of sufficient height. The air never being dry, we get in practice always a mixture of generator gas and water gas, and also gases of distillation if crude, uncoked fuel is used.

(3) Water gas is used for illuminating and fuel purposes.

(4) Semi-water gas or Dowson gas is used for fuel and power purposes, and is prepared by leading a mixture of air and steam through a coal layer in a producer.

CHAPTER XX.

PRODUCER GAS.

If air is led at moderate speed through a layer of pure carbon (in practice charcoal or coke), incomplete combustion takes place; *i.e.* by the reaction of oxygen on the glowing coal, formation of carbon monoxide occurs:

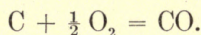

Supposing the air to contain 4 mols nitrogen to 1 mol oxygen, which is probably correct, we can write the reaction:

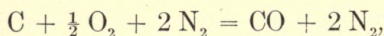

and we get a gas which theoretically contains 2 mols N_2 to 1 mol CO , and should have the composition:

CO 33.3 per cent by volume.

N 66.7 per cent by volume.

This gas ought to yield per 22.42 liters if burned at constant volume $0.333 \times 67.9 = 22.61$ cal. If burned at constant pressure $22.61 + 0.5 \times 0.54 = 22.88$ cal. The thermal value of the same at constant pressure would be per cubic meter 1020.5 cal.

The thermal value of 1 gram of gas is calculated as follows: According to the equation the gas has for every gram atom of carbon

12 grams carbon	} 28 grams carbon monoxide.
16 grams oxygen	
56 grams nitrogen.	
Sum 84 grams.	

As 84 grams of gas contain 3 mols ($\text{CO} + 2 \text{N}_2$), 22.42 liters of the same at 0°C . and 760 mm. are equal to 28 grams, and therefore 1 gram of gas generates 817 cal.

This reaction, however, only takes place at very high tempera-

tures. At lower temperatures a second reaction occurs simultaneously, and the extent to which it occurs increases with decreasing temperature. This reaction is

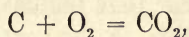

or, if the air is used instead of oxygen,

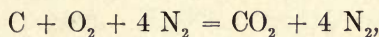

Between these two reactions there exists a certain equilibrium for every temperature and pressure. If we subtract the equation

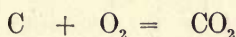

from

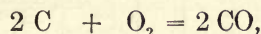

we get

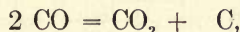

which reaction actually takes place at fairly high temperatures, and determines the proportion of the two first reactions. It is reversible:

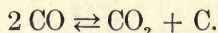

That is, while pure CO within certain temperatures is decomposed into CO_2 and C, we find that under similar conditions CO is produced by reduction of CO_2 by means of C. Therefore, there exists necessarily an equilibrium between CO, CO_2 and C, which depends on the temperature and concentration (gas pressure).

Since out of two volumes CO only one volume CO_2 is formed, and since the reaction, according to our equation (from left to right), takes place without decrease of volume, it is clear that an increase of pressure facilitates the formation of CO_2 , while a decrease of pressure favors the formation of CO. Therefore, the primary air (wind) in a gas producer should be of low pressure if a gas high in CO is desired.

The influence of temperature on the equilibrium is shown by the balance of the reaction heats:

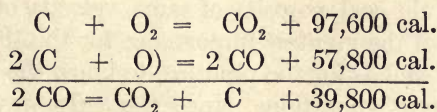

i.e., the decomposition of 2CO into CO_2 and C takes place under generation of heat. Therefore an increase of temperature facilitates the formation, a decrease of temperature the decomposition of CO . Thence it is clear that the gas will be the richer in CO with higher temperature.

All these observations are of importance for the state of equilibrium. Whether this is reached in practice or not depends on

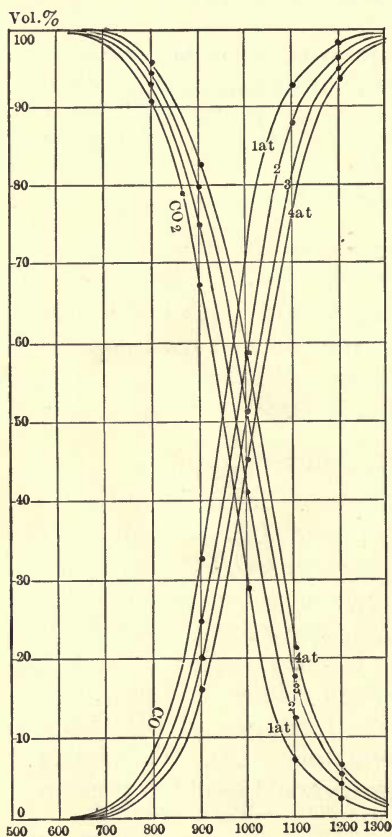

FIG. 82. — Ideal Composition of Generator Gas from Pure Oxygen.

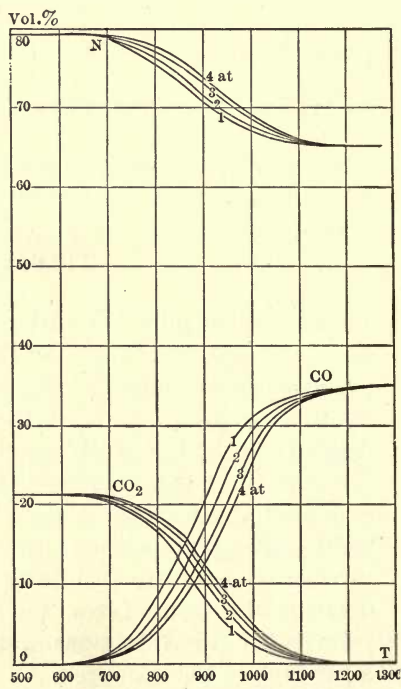

FIG. 83. — Ideal Composition of Generator Gas from Dry Air.

the height of the coal, porosity of same, velocity of wind, etc. It is, however, of the greatest importance for the theory of the gas producers as well as for the practice, to know the equilibrium for all the different conditions, since the only way to judge the

quality of a gas producer process is to compare the results obtained in practice with those corresponding to the theoretical equilibrium.

We therefore give in Tables CXI, CXII, and CXIII the ideal composition of generator gas at different temperatures and pressures.

Table CXI gives the ideal composition of producer gas, produced with pure oxygen. Fig. 82 shows the content of this table graphically.

TABLE CXI.

IDEAL COMPOSITION OF PRODUCER GAS (GENERATOR GAS) PRODUCED WITH PURE OXYGEN.

Air Pressure. Volumetric Composition at a Temperature of	1 Atmosphere.		2 Atmospheres.	
	CO	CO ₂	CO	CO ₂
227° C. 500° abs.	0.004	99.996	0.0028	99.9972
327° 600°	0.123	99.877	0.087	99.913
427° 700°	1.427	98.573	1.011	98.989
527° 800°	8.794	91.206	6.303	93.697
627° 900°	32.542	67.458	24.809	79.191
727° 1000°	70.35	29.65	58.105	42.259
827° 1100°	92.75	7.25	87.198	12.802
927° 1200°	98.445	1.555	97.00	3.00
1027° 1300°	99.50	0.50	99.00	1.00

Air Pressure. Volumetric Composition at a Temperature of	3 Atmospheres.		4 Atmospheres.	
	CO	CO ₂	CO	CO ₂
227° C. 500° abs.	0.0023	99.9977	0.002	99.998
327° 600°	0.0711	99.9289	0.061	99.939
427° 700°	0.826	99.174	0.716	99.284
527° 800°	5.177	94.823	4.499	95.591
627° 900°	20.408	79.592	17.945	82.055
727° 1000°	51.788	48.212	47.017	52.983
827° 1100°	82.72	17.28	78.987	21.013
927° 1200°	95.65	4.35	94.315	5.685
1027° 1300°	98.97	1.03	98.67	1.33

Table CXII gives the ideal composition of producer gas, produced with dry atmospheric air. The data of this table are graphically shown in Fig. 83.

TABLE CXII.

IDEAL COMPOSITION OF PRODUCER GAS (GENERATOR GAS) PRODUCED
WITH DRY ATMOSPHERIC AIR.

Air Pressure = 1 Atmosphere.

Gasifying Temperature.		Partial Pressure of CO + CO ₂ .	Composition in Per Cent by Volume.		
° C.	T° abs.		In Atm.	CO ₂ .	CO.
227°	500°	0.21	21.00	79.00
327°	600°	0.21	21.00	79.00
427°	700°	0.2145	20.31	1.14	78.55
527°	800°	0.24	16.40	7.60	76.00
627°	900°	0.29	8.75	20.25	71.00
727°	1000°	0.334	2.14	31.26	66.60
827°	1100°	0.344	0.47	33.93	65.60
927°	1200°	0.346	0.14	34.46	65.40
1027°	1300°	0.3465	0.01	34.65	65.35
Air Pressure = 2 Atmospheres.					
227°	500°	0.42	21.00	79.00
327°	600°	0.42	21.00	79.00
427°	700°	0.4228	20.39	1.01	78.60
527°	800°	0.466	18.14	5.82	76.70
627°	900°	0.555	11.94	17.09	72.25
727°	1000°	0.6535	4.31	29.56	67.32
827°	1100°	0.6865	0.83	33.74	65.67
927°	1200°	0.692	0.21	34.44	65.40
1027°	1300°	0.693	0.10	34.56	65.35
Air Pressure = 3 Atmospheres.					
227°	500°	0.63	21.00	79.00
327°	600°	0.63	21.00	79.00
427°	700°	0.6395	20.51	0.81	78.68
527°	800°	0.686	18.14	4.76	77.00
627°	900°	0.8075	11.94	14.98	73.08
727°	1000°	0.957	4.31	27.59	68.10
827°	1100°	1.625	0.83	33.37	65.80
927°	1200°	1.0365	0.21	34.34	65.45
1027°	1300°	1.04	0.10	34.56	65.34

TABLE CXII.—Continued
Air Pressure = 4 Atmospheres.

Gasifying Temperature.		Partial Pressure of CO+CO ₂ .	Composition in Per Cent by Volume.		
° C.	T° abs.		In Atm.	CO ₂ .	CO.
227°	500°	0.84	21.00	79.00
327°	600°	0.84	21.00	79.00
427°	700°	0.851	20.59	0.71	78.70
527°	800°	0.905	18.52	4.11	77.37
627°	900°	1.056	12.73	13.67	73.60
727°	1000°	1.258	5.00	26.46	68.55
827°	1100°	1.359	1.13	32.85	66.02
927°	1200°	1.381	0.28	34.25	65.47
1027°	1300°	1.385	0.13	34.50	65.37

TABLE CXIII.

IDEAL COMPOSITION OF PRODUCER GAS (GENERATOR GAS) PRODUCED WITH 50 PER CENT OXYGEN.

Air Pressure = 1 Atmosphere.

Gasifying Temperature.		Partial Pressure of CO+CO ₂ .	Composition in Per Cent by Volume.		
° C.	T° abs.		In Atm.	CO ₂ .	CO.
227°	500°	0.50	50.00	50.00
327°	600°	0.50	50.00	50.00
427°	700°	0.502	49.40	0.80	49.80
527°	800°	0.522	43.40	8.80	47.80
627°	900°	0.568	29.60	27.20	43.20
727°	1000°	0.633	10.10	53.20	36.70
827°	1100°	0.66	2.00	64.00	34.00
927°	1200°	0.663	1.10	65.20	33.70
1027°	1300°	0.6655	0.35	66.20	33.45

Air Pressure = 2 Atmospheres.

227°	500°	1.	49.56	50.00
327°	600°	1.	45.65	50.00
427°	700°	1.0035	34.03	0.61	49.83
527°	800°	1.0295	15.50	5.83	48.52
627°	900°	1.1065	34.03	21.30	44.67
727°	1000°	1.23	15.50	46.00	38.50
827°	1100°	1.308	3.80	61.60	34.60
927°	1200°	1.326	1.10	65.20	33.70
1027°	1300°	1.3305	0.43	66.10	33.47

TABLE CXIII. — *Continued*

Air Pressure = 3 Atmospheres.

Gasifying Temperature		Partial Pressure of CO + CO ₂ .	Composition in Per Cent by Volume.		
° C.	T° abs.		In Atm.	CO ₂ .	CO.
227°	500°	1.5	50.00	50.00
327°	600°	1.5	50.00	50.00
427°	700°	1.5045	49.55	0.60	49.85
527°	800°	1.538	46.20	5.07	48.73
627°	900°	1.6345	36.55	17.93	45.52
727°	1000°	1.814	18.60	41.87	39.53
827°	1100°	1.9455	5.45	59.40	35.15
927°	1200°	1.986	1.40	64.80	33.80
1027°	1300°	1.9955	0.45	66.07	33.48

Air Pressure = 4 Atmospheres.

227°	500°	2.	50.00	50.00
327°	600°	2.	50.00	50.00
427°	700°	2.0053	49.60	0.54	49.86
527°	800°	2.0443	46.68	4.43	48.89
627°	900°	2.1615	37.89	16.15	45.96
727°	1000°	2.384	21.20	38.40	40.40
827°	1100°	2.588	5.90	58.80	35.30
927°	1200°	2.6435	1.74	64.35	33.91
1027°	1300°	2.6605	0.46	66.05	33.49

Since it is not improbable that in future a mixture of 50 per cent oxygen and 50 per cent nitrogen may be used in gas producers, the data for this case are given in Table CXIII. Fig. 84 gives the results graphically.

The following important general conclusions may be drawn from these tables and diagrams:

1. In all cases the CO₂ content of the ideal generator gas at low temperature is a maximum, which is practically constant up to 400° C.

2. With increasing temperature the CO₂ content is decreasing; between 800° and 1000° C. no CO₂ is present.

3. No CO is found up to about 400° C.

4. With increasing temperature the CO content is increasing and is reaching a maximum at 800° to 1000° C.

5. At constant temperature the CO₂ content is increasing with

the pressure, and therefore also with the oxygen content of the primary air.

6. CO shows the opposite property.

7. At low temperatures the absolute CO₂ content is increasing with the oxygen content of the primary air.

8. At high temperatures the absolute content of the gas in CO is increasing with the oxygen content of the primary air.

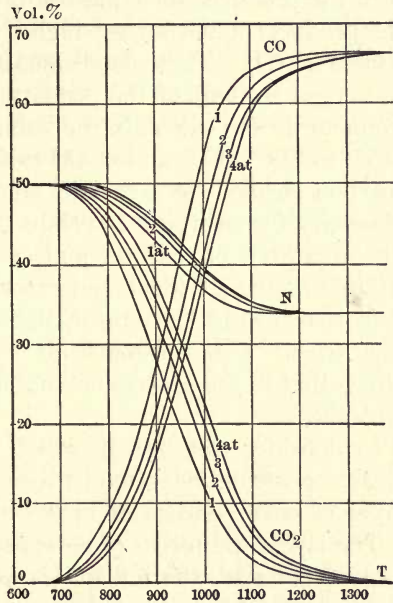

FIG. 84. — Ideal Composition of Generator Gas from 50 per cent Oxygen.

Therefore the following facts have to be considered for getting a generator gas of the highest possible thermal value and also rich in CO.

1. The oxygen content of the primary air being the same, the gasifying temperature has to be high. In practice a temperature of 700° to 900° C. is sufficient, as at this temperature the maximum CO content is practically reached.

2. At high gasifying temperatures the quality of generator gas, *i.e.*, the content of CO, is increasing with the oxygen content of the primary air.

3. High air (wind) pressures are unfavorable, as thereby, under otherwise constant conditions, the CO₂ content is increased. If,

however, it is desired to generate the largest possible quantity of CO_2 in the producer, which is sometimes the case in the hot blowing period of the water-gas process for the purpose of rapidly increasing the temperature, a very low temperature has to be kept during the process if the equilibrium is to be reached. This is easily understood, as with increasing temperature the quantity of the CO formed is rapidly increasing, and the quantity of CO_2 is decreasing. If in the producer the equilibrium is reached, the temperature of the producer must not get high if it is the intention to get a high yield of CO_2 . These conditions are not changed by increasing the oxygen content of the primary air.

From the above facts we can calculate the volume proportions of CO_2 to CO, of CO_2 to $\text{CO} + \text{CO}_2$ and of CO to $\text{CO} + \text{CO}_2$, also the quantity of carbon gasified by a certain volume of air, the quantity of air necessary for gasifying a certain quantity of carbon, and also the quantity of carbon and air required for generating a certain volume of ideal generator gas.

We have so far treated the ideal generator gas, *i.e.*, a gas which is produced by the action of dry primary air on glowing coal, under the supposition that in the process of combustion the state of equilibrium is reached.

We now have to consider the case in which equilibrium is not reached, this case occurring very frequently in practice.

Every single layer of coke consists of pieces of coke and air spaces between. The larger the pieces of coke the larger the air spaces. With coke of fist size, the air spaces amount to one-quarter to one-fifth of the total volume, and these spaces allow the air to pass through the producer.

Every piece of coal, therefore, is surrounded by a layer of air varying in thickness from a few millimeters to a few centimeters. The reaction between the oxygen of the air and the coal takes place only on their contact points, and the question arises which reaction will occur first. The law of the gradual reactions states that wherever several reactions might take place, the first reaction is that one which corresponds to the least stable state, then the next stable, and at last the most stable.

In our case we have but two possible reactions: The formation of CO_2 and CO, and we have to find out which one of the two is more stable. We, therefore, have to consider the free energies of formation of the two compounds.

Under the supposition that the concentration of the free oxygen is one atmosphere, we find that the curves of the two energies of formation go through the same point at a little below 1000° abs. (about 700° C.), and that at lower temperatures the free energy of formation of the CO_2 is the larger one, at higher temperatures, that of CO. We find the same relation in the stability of the two compounds, and, therefore, at the beginning of the reaction at low temperatures first of all CO, at higher temperatures first of all CO_2 , will be formed. In rising upwards the gases will further react with the upper layers of coal and with the air contained in the interior part of the gas current.

The reaction of the outer part of the gas current with coal consists either in combustion of coal by means of CO_2 or in formation of carbon from carbon monoxide ($2\text{CO} = \text{CO}_2 + \text{C}$). Since at low temperatures first of all CO, is formed, the most plausible reaction under such condition is the decomposition of the CO and formation of C. The reaction, however, between the inner and outer parts of the gas current counteracts this decomposition, since the O of the inner part would burn any C which was deposited from the CO. The velocity of diffusion and mixture between the inner and outer parts of the gas current being sufficiently large, no C will be deposited; on the contrary, the CO formed will be burned to CO_2 , and the oxygen going to the outer part will oxidize some more carbon. Therefore the average composition of the gas will approach more and more the equilibrium.

At higher temperatures at first CO_2 is formed, and this will, by contact with the higher layers of coal, oxidize some C to CO. On the other hand, the oxygen of the inner part will tend to oxidize the CO present to CO_2 .

In both cases we have two effects counteracting each other. At low temperatures the reaction between coal and the outer layer of gas tends to prevent the reaching of equilibrium, while the reaction between outer and inner layers favors the approach to the equilibrium. At high temperatures, however, we find that the reaction between gas and coal favors the equilibrium, and the reaction in the gas current works against it.

The conditions become still more complicated if we consider that the actual velocity of the gas current at different points of the generator varies according to the unequal dimensions of the air spaces, and that also the temperature throughout the genera-

tor is not at all uniform. If the generator is working with the fire on top (maximum temperature in the upper parts of the charge), the state of equilibrium of the rising gas current is getting more and more favorable to the formation of CO.

The reverse is true with the maximum temperature in the lower parts of the producer. The location of the maximum temperature of the producer, however, changes during the operation. In starting the fire the upper layers of the generator will be cold, and will allow the formation of CO₂. They are gradually heated up by radiation of heat from the combustion gases to the coal, and the hot zone will therefore extend from the bottom further upwards. After continued blowing we can imagine a coke column which has the combustion temperature of the hot carbon in cold air.

As will be seen from the above considerations the research of the generator process is extremely difficult, and we have but a few scientific investigations on this subject. One of the best is by O. Boudouard, even this being not free from objectionable points. He passed air at different speeds through a tube filled with charcoal and analyzed the gases obtained. He found at 800° C. the results given in Table CXIV:

TABLE CXIV.
ANALYSIS OF PRODUCER GAS. (Per Cent by Volume.)

Gas.	Flow in Liters per Minute.				
	0.10	0.27	1.30	1.4655	3.20
CO ₂	18.2	18.43	18.92	19.9	19.4
CO.....	5.2	3.8	1.88	1.83	0.93
O ₂	0.47	0.94	0.93
N ₂ (difference).....	76.6	77.30	78.26	78.27	78.74

The analysis corresponding to the equilibrium at this temperature is

CO₂ 0.92 per cent by volume,
CO 34.32 per cent by volume,
N 74.76 per cent by volume.

It will be noticed that the gases from Boudouard's experiments are very high in CO₂ and very low in CO. In three cases they also contain free oxygen. This is in accordance with the fact that at 800° C., CO₂ is less stable than CO, so that, therefore, CO₂ must be formed first and the gas composition is approaching the equilibrium but gradually.

To better understand these conditions we are going to decompose the gases into the elementary components. We have in 22.42 liters of gas the amounts given in Table CXV.

TABLE CXV.
ELEMENTARY COMPONENTS OF PRODUCER GAS.

Flow in Liters per Minute.	Gram-atoms C. in			CO ₂ .	Mol. Oxygen in		Total.	Nitro- gen.	Prim- ary Air.
	CO ₂ .	CO.	Total.		CO.	Free.			
0.	0.92	34.32	35.24	0.92	17.62	18.54	64.76	83.30
0.0	18.2	5.2	23.4	18.2	2.6	20.8	76.6	97.4
0.27	18.43	3.8	22.23	18.43	1.9	0.47	20.8	77.30	98.1
1.30	18.92	1.88	20.80	18.92	0.94	0.94	20.8	78.26	99.06
1.465	19.9	1.83	21.73	18.9	0.92	20.18	78.27	98.45
3.20	19.4	0.93	20.33	19.4	0.47	0.93	21.20	78.74	99.94

According to the law of gradual reaction in the beginning, a thin layer of CO₂ is formed, which then oxidizes the coal layer through which it passes. It will, therefore, be pretty nearly correct to suppose that the outer layer (surface) of the gas current will have, shortly after its entrance into the tube, the composition which corresponds to the equilibrium. In this case the ratio of CO₂ to CO₂ + CO must be equal to 0.0261, and there must have been formed the amounts given in Table CXVI:

TABLE CXVI.

Flow in Liters per Minute.	Vol. CO ₂ .	Vol. CO.	Oxygen in Same.	Corresponding Amount of Air.
0.10	0.61	22.79	12.01	57.19
0.27	0.58	21.65	11.41	54.33
1.30	0.54	20.26	10.67	50.81
1.465	0.54	20.19	10.64	50.67
3.20	0.53	19.80	10.43	49.67

If we deduct the air volume actually used for the original combustion from the volume of primary air, we get the surplus quantity of air from which we can figure by a simple way the surplus air given in Table CXVII and Fig. 85.

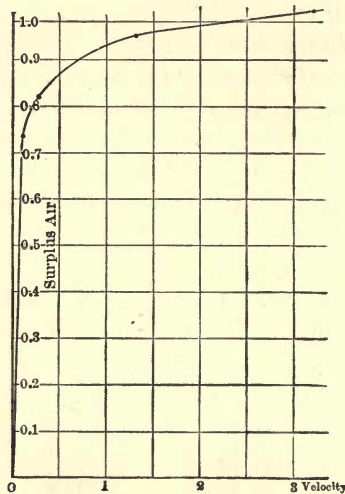

FIG. 85. — Curve of Surplus Air.

TABLE CXVII.

SURPLUS AIR FOR COMBUSTION.

Flow in Liters per Minute.	In 100 Volumes Generator Gas Volumes of			Of 100 Volumes Primary Air.		N Times Surplus Air.
	Primary Air.	Air for Original Combustion.	Surplus Quantity of Air.	For Original Combustion.	Surplus Air.	
0.10	97.40	57.19	40.21	58.72	41.28	0.737
0.27	98.10	54.33	43.77	55.38	44.62	0.805
1.30	99.06	50.81	48.25	51.29	48.71	0.949
1.465	98.45	50.67	47.78	51.46	48.54	0.943
3.20	99.94	49.67	50.27	49.70	50.30	1.012

The following consideration will be still more useful for the practical regulation of this process:

We suppose again that in the first moment the least stable gas is formed, but that in a short time on the surface area the equilibrium corresponding to the actual gasifying temperature will be reached. In the further course of the process this equilibrium will, however, be disturbed by the gradual mixture of the outer gas layer with the inner air volume, by the fall in temperature resulting therefrom, and by the combustion of a part of the original CO to CO₂, due to the surplus oxygen.

Referring again to Boudouard's experiments at 800° C., we can calculate from the free oxygen content of the gases the corresponding amount of air, deduct the latter from the composition of the gas, calculate the temperature of equilibrium corresponding to the gas mixture obtained, and compare the temperature of equilibrium with the actual gasifying temperature (800° C. = 1073° abs.). We obtain thereby the results given in Table CXVIII.

TABLE CXVIII.

IDEAL GASIFYING TEMPERATURE, ETC.

	Flow in Liters per Minute.					
	0	0.10	0.27	1.30	1.465	3.9°
Free oxygen, per cent by vol....			0.47	0.94		0.93
Corresponding amount of air, per cent by volume.....			2.24	4.48		4.43
Composition of the gas (CO ₂	0.92	18.2	18.85	19.81	19.9	20.20
free from air, per cent (CO.....	34.32	5.2	3.89	1.98	1.83	0.97
by volume (N ₂	64.76	76.6	77.26	78.21	78.27	78.74
Gasifying temperature (absol.), corresponding to the com- position.....	1073°	763°	749°	732°	729°	700°
Difference between the latter and the actual gasifying tem- perature, which is higher by..	0°	307°	324°	341°	344°	373°

As may be seen from Table CXVIII and from Fig. 86, the "ideal" (or apparent) gasifying temperature corresponding to the actual composition of the gas is clearly below the actual, and the curve of this difference of temperatures consists of two practically straight branches, which are connected with each other

by a short, sharply bent curve. In the one branch, which is practically vertical, the velocity of reaction is the main factor, while in the inclined branch the velocity of the wind is of main importance.

Naturally, the position and shape of this curve depends, not only on the gasifying temperature, but also on the size of coal used, and on the height of the fuel layer. Under conditions, however, which can be compared with each other, these additional

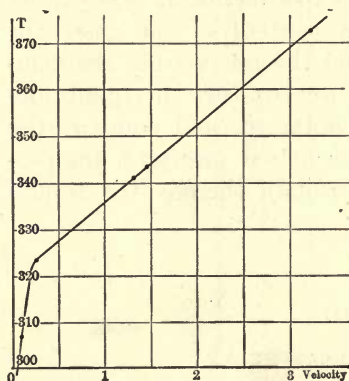

FIG. 86. — Difference of Temperature between Actual and Apparent Gasifying Temperature.

factors will have the same character and the position of the bending point of the curve seems a very suitable characteristic point for the conditions.

With increasing gasifying temperature, the velocity of reaction increases, and the bending point of the curve will move to the right. Increase of the fuel height and decrease of the coal size will have a similar effect. In the latter cases, however, some other influences have to be considered, such as friction between gas current and coal

pieces, heating of the upper layers by the rising gas, location of the maximum temperature in the generator, etc.

The following figures are given as practical results of generators that were charged with carbonized fuel.

Ebelman gasified at Audincourt small-sized charcoal in a pressure producer, which had the shape of a small blast furnace, and he obtained a gas of the following composition (per cent by weight):

CO	34.1 per cent
CO ₂	0.8 per cent
N	64.9 per cent
H ₂	0.2 per cent
		<hr/> 100.0 per cent.

In a gas producer at Pous l'Eveque, which was charged with coke, he obtained a gas of the following composition:

CO	33.8 per cent
CO ₂	1.3 per cent
N	64.8 per cent
H ₂	0.1 per cent
	<hr/> 100.0 per cent.

MIXED DISTILLATION AND COMBUSTION GASES.

If we subject natural uncarbonized fuel in proper apparatus (gas generators, also called gas producers) to incomplete combustion, mixed distillation and combustion gases are formed. In the upper layers of the producer the hygroscopic water is removed. In further going downwards the fuel (material to be gasified) is subjected to dry distillation, coke being the result of this process. The coke is burned incompletely in the lowest part of the producer, whereby, besides the heat necessary for evaporation and dry distillation, CO is also generated. The water which is introduced as moisture with the atmospheric air is also decomposed. A clear idea of these processes is given in the table below, without, however, taking into account the formation of tar, which is inconsiderable.

Composition of the coal used (bituminous coal of Ostrau, Moravia) mixed with lignite of Leoben (Styria).

	C = 64.92
	H ₂ = 2.50
	N = 0.50
Chemically combined water	14.22
Hygroscopic water	12.42
Ash	5.44
	<hr/> 100.00
Combustible sulphur	0.52
Calorific value	6374 calories.

(a) Process in the upper part of the generator (drying of coal): 100 kg. coal yield 12.42 water (steam), and 87.58 kg. dry coal.

(b) Process in the middle part of the generator (dry distillation of coal).

TABLE CXIX.
ELEMENTARY ANALYSIS OF COAL AND PRODUCTS OF DISTILLATION.

87.58 Kg. Dry Coal Contain.		Yield.						
		Coke. Kg.	Gases of Distillation Kg.					
			H ₂ O.	CO.	CH ₄ .	H ₂ .	NH ₃ .	H ₂ S.
Ash.....	4.92	4.92
C.....	64.92	58.73	5.67	0.52
N.....	0.50	0.50
S.....	0.52	0.12	0.40
H ₂	4.08	0.635	0.17	3.14	0.11	0.025
O.....	12.64	5.08	7.56
Sum.....	87.58	63.77	5.715	13.23	0.69	3.14	0.61	0.425

TABLE CXX.
ELEMENTARY ANALYSIS OF COAL AND PRODUCTS OF COMBUSTION.

Components in Kg.	Coke.	Air.	Sum.	Yields.				
				Losses thr'h Grate Open- ings.	Gases.			
					CO ₂ .	CO.	H ₂ O.	N.
Ash.....	4.92	4.92	4.92
C.....	58.73	58.73	15.67	6.57	36.49
N.....	211.63	211.63	211.63
S.....	0.12	0.12	0.12
H ₂ O {	H ₂	0.25	0.25	0.25
		O	64.49	64.49	0.25	17.51	48.65
Sum.....	63.77	276.37	340.14	20.96	24.08	85.14	0.25	211.63

We suppose that the coke contains nothing but carbon, besides the ash, and that the gases of dry distillation contain no oxygen except as CO and H₂O (the latter supposition is not quite, but sufficiently correct, since the gases contain CO₁ and other oxygen compounds). The formation of tar is not taken into consideration.

Since only a small amount of N is present, we calculate the entire amount as NH₃; actually, however, but one-fifth of the nitrogen of coal is transformed into NH₃.

(c) Process on and just above the grate (incomplete combustion of the coke formed).

The coal analysis shows 5.44 per cent ash, while the table shows only 4.92 per cent, which is explained by oxidation, mainly formation of sulphates from Fe_2S . The composition of gas shown in the last table results from the average composition of generator gas and the composition of the gases of distillation, which is given in Table CXIX.

The distribution of heat in the generator is shown in the heat balance, Table CXXI.

TABLE CXXI.
HEAT DISTRIBUTION IN GENERATOR.

Production of Heat and Non-Produced Heat.	Single.		Combined.	
	Cal.	Per Cent.	Cal.	Per Cent.
I. Production of heat:				
1. Heat produced in generator by chemical processes.....	179666.4	26.67		
2. Heat introduced by coal and air (by their temperature)....	3337.9	0.49		
			183004.3	27.16
II. Non-produced heat:				
1. Unburned coal falling through the grate.....	126613.6	18.79		
2. Heat capacity of generator gases	364028.0	54.05		
			490641.6	72.84
III. Heat losses:				
1. By fuel and ash falling through grate.....	2316.1	0.34		
2. By heat carried away by the gas produced.....	28282.0	4.20		
3. Loss by moisture of gas.....	12346.3	1.83		
4. By decomposition of water....	8615.5	1.28		
5. (a) Radiation.....	94890.7	14.09		
(b) Heat necessary for gasifying coal.....	36553.5	5.42		
			183004.3	27.16
IV. Non-produced heat:				
By unburned coal falling through grate.....			126613.6	18.79
			309617.9	45.95
Heat gained.....			364028.0	54.05
			673645.9	100.00

It is understood that the composition of generator gas depends, besides the quality of fuel, on the size of same, height of fuel layer, construction of generator, and also temperature and air pressure during the operation. Table CXXI was prepared by Richard Akerman.

TABLE CXXII.

GENERATOR GAS FROM WOOD OF FIR TREES.

Kind of Fuel.	Trunks and Roots.	Brush-wood.	Logwood.	Sawmill Refuse.		
Size. {	Thickness.....m.m.	20-35	35-150	20-200		
	Length.....m.m.	500-750	maximum 200	maximum 340		
Contents:						
	Hygroscopic water, per cent...	12.	16.	27.	60.	
	Ash, per cent.....	0.9	0.6	0.5	0.3	
	Wood substance, per cent.....	87.1	83.4	72.5	39.7	
Composition of wood substance:						
	C, per cent.....	53.0	?	51.0	?	
	H ₂ , per cent.....	7.1	?	6.1	?	
	O, per cent.....	39.8	?	} 29.4 {	?	
	N, per cent.....	0.1	?		?	
	Grate area, square meter, of gen. generator.....	0.0	0.81	1.72	1.37	
	Cubic content, cubic meters, of generator.....	26.7	1.9	24.2	7.4	
Consumption of fuel per day:						
	Per sq. meter grate area {	8.1	23.8	14.4	
			kg.	1654	8891	7909
	Per generator..... {	65.2	6.6	41.0	19.7
			kg.	14866	1340	15293
	Number of charges per 24 hours..	2.8	5.6	4.1	6.6	
	Length of time of presence of fuel in generator (hours).....	8.6	4.3	5.9	3.6	
	Temperature of gas leaving generator, degrees C.....	180°	505°	147°	125°	
	Kg. tar in 24 hours.....	?	?	444	?	
Composition of tar:						
	C, per cent.....	75.5	
	H ₂ , per cent.....	7.4	
	O, per cent.....	16.6	
	N, per cent.....	0.5	
Volume composition of gases free of moisture and air:						
	CO ₂	3.8	6.2	6.0	11.3	
	CO.....	29.8	26.0	29.8	19.6	
	C ₂ H ₄	0.6	0.3	0.9	
	CH ₄	4.2	5.1	6.9	4.3	
	H ₃	6.4	4.3	6.5	7.4	
	N ₂	55.2	58.4	50.5	56.5	

TABLE CXXIII.

GENERATOR GAS FROM PEAT.

Origin. Quantity of Peat.		Munkfors Good Fibrous Peat.	Lotorp Good Fibrous Peat.
Inter- mediate analysis	{ Hygroscopic water, per cent	25.0	36.0
	{ Gases, noncombustible	8.3	17.6
	{ Gases, combustible	39.0	16.9
	{ Fixed carbon, per cent	24.9	24.0
	{ Ash, per cent	2.8	5.5
Composition of peat substance	{ C, per cent	57.8	61.0
	{ H ₂ , per cent	6.8	6.3
	{ O, per cent	34.0	30.6
	{ N, per cent	1.4	2.1
Grate area, square meters	0.0	1.6	
Cubic content, cubic meters	{ of generator	22.8	21.9
	{ Cubic meter		12.8
Daily fuel con- sumpt'n.	{ Per sq. meter grate area		5279
	{ Kg.		40.2
	{ Cubic meter	20.6	40.2
Per generator	{ Kg.	6262	8446
	{ Kg.	1.3	1.1
Number of charges per 24 hours		1.3	1.1
Length of time for which fuel remains in gener- ator in hours	18.5		21.8
Temperature of gas leaving producer, deg. C	86-100°		75-105°
Kg. tar in 24 hours	152		173
Composition of tar	{ C	79.6	79.8
	{ H ₂	9.3	9.2
	{ O		9.6
	{ N	11.1	1.4
Composition of gas free of air and water	{ CO ₂ , vol. per cent	6.6	6.8 - 7.4
	{ CO	29.6	27.6 - 26.2
	{ C ₂ H ₄	0.7	0.4 - 0.4
	{ CH ₄	4.0	3.75 - 3.70
	{ H ₂	5.3	12.3 - 13.5
{ N ₂	53.8	49.15 - 48.8	

TABLE CXXIV.

GENERATOR GAS FROM BITUMINOUS COAL.

Intermediate analysis	{ Hygroscopic water, per cent	7.6
	{ Gases, non-combustible, per cent	9.1
	{ Gases, combustible, per cent	13.6
	{ Coked coal, per cent	64.6
Composition of coal substance	{ Ash	5.1
	{ C, per cent	79.0
	{ H ₂ , per cent	5.9
	{ O, per cent	13.7
	{ N, per cent	1.4

TABLE CXXIV. — *Continued.*

Limestone addition, per cent.....	3.4
Residue in ash-pit {	Weight in per cent of coal..... 12.1
Composition {	C, per cent..... 40.2
	H ₂ , per cent..... 1.0
	O ₂ + N ₂ , per cent..... 1.2
	Ash..... 57.6
Grate area, square meters, of generator.....	2.0
Cubic content, cubic meters, of generator.....	4.0
Daily consumption of coal per {	Sq. m. grate area {
	Cu. m.... 1.7
	Kg..... 1251
Generator..... {	Cu. m.... 3.4
	Kg..... 2502
Number of charges per 24 hours.....	1.2
Length of time for which fuel remains in generator.....	20
Temperature of gas leaving generator, deg. C.....	500°
Composition of gases free of air and water.....	CO ₂ , vol. per cent..... 1.8
	CO..... 27.3
	C ₂ H ₄ 0.4
	CH ₄ 4.2
	H ₂ 6.2
	N ₂ 60.1

TABLE CXXV.

GENERATOR GAS FROM LIGNITE.

Below are given results with a lignite generator:

Number of generators.....	3
Grate area per generator.....	2.5 square meters
Duration of test.....	12 hours 45 minutes
Coal charged.....	3600 kg. Leoben (Styria) coal
Composition of coal {	C..... 61.72 per cent
	Volatile H ₂ 1.85 per cent
	N..... 0.22 per cent
	H ₂ O chemically combined..... 20.09
	H ₂ O hygroscopic..... 9.34
	Ash..... 6.78
	Combustible S..... 0.37
Calorific value.....	5446 kg. cal.

Losses through grate.....	936.7 kg.					
Composition of losses {	73.94 per cent.					
	26.06 per cent.					
	1	2	3	4	Average.	
Composition of dry generator gas... {	CO ₂ , vol. per cent	5.3	5.4	4.2	4.4	4.64
	O ₂ , " "	0.3	0.8	0.6	0.8	0.65
	CO, " "	25.19	25.05	25.39	26.50	25.59
	CH ₄ , " "	0.29	0.15	0.51	0.40	0.38
	H ₂ , " "	10.29	10.65	11.29	11.60	11.11
	N ₂ ,.....	58.63	57.95	58.01	56.30	57.63

TABLE CXXVI.

QUANTITY GASIFIED PER HOUR AND SQUARE METER GRATE
AREA.

Logwood and sawdust mixed	45- 50 kg.
Sawmill waste	200-330 "
Logwood	370 "
Loose peat (bad quality).....	75-120 "
Good fibrous peat.....	200-250 "
Lignite.....	40- 50 "
Bituminous coal.....	60-250 "

SUGGESTIONS FOR LESSONS.

Air (generator) gas has to be made in a small experimental producer using different grades of fuel, varying height of fuel layer and air of different pressures. Gas and fuel is to be analyzed, the quantity of the fuel consumed and of the gas generated to be found and the balance of the process to be put up. The results are to be compared with the ideal process.

On a small scale (in glass and porcelain tubes) experiments can be made for demonstrating the influence of the length of the tube (fuel height) and velocity of the wind.

CHAPTER XXI.

WATER GAS.

INSTEAD of producing fuel gases by the action of the oxygen in the air on glowing coal, we can use for this purpose the oxygen of water in place of the oxygen in the air.

If steam is led over glowing coal, two different reactions will take place depending on the temperature. At very high temperatures the reaction takes place according to the equation

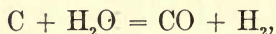

while with decreasing temperature a second reaction becomes more and more prevalent according to equation



The first equation is furnishing a mixture of equal volumes of CO and H₂, CO 50 per cent by volume and H₂ 50 per cent by volume, while the second reaction, if taking place exclusively, furnishes a gas containing two volumes H₂ for every one volume of CO₂, hence CO₂ 33.33 per cent by volume and H₂ 66.67 per cent by volume. The thermal value of the first gas per 22.42 liters is 68 cal., of the second gas, 45.4 cal.

A comparison of the generator (air) gas process with the two water gas processes shows:

TABLE CXXVII.
PRODUCER AND WATER GAS PROCESSES.

	Volume Per Cent.					Of Mixture at Constant Pressure. Cal.
	H ₂ .	CO.	CO ₂ .	N ₂ .	Thermal Value of 1 Volume. Cal.	
1 C + $\frac{1}{2}$ (O ₂) - 2 N ₂ = CO + 2 N	33 $\frac{1}{3}$	66 $\frac{2}{3}$	22.6	22.9
2 C + 2 H ₂ O = CO ₂ + 2 H ₂	66 $\frac{2}{3}$	33 $\frac{1}{3}$	45.4	46.5
3 C + H ₂ O = CO + H ₂	50	50	68.0	68.5

The figures of thermal value refer to the same gas volume in each case, and are well adapted for comparing the qualities of the gases. In case, however, we want to consider the utilization of fuel, we have to refer the thermal values to equal quantities of carbon (equal volumes of CO and CO₂), and we obtain:

	12 Grams C. Yield Liters of Gas.	Value of the Gas at Constant	
		Volume.	Pressure.
1	67.26	67.8 cal.	68.7 cal.
2	67.26	113.3 cal.	116.1 cal.
3	44.84	125.8 cal.	126.8 cal.

We see that water gas even under the most unfavorable circumstances yields more heat (thermal value) than the ideal air (generator) gas, besides the fact that it contains less non-combustible gases.

For making a perfect comparison we have to calculate at least — if not the pyrometric heating effect — the quantity of air theoretically required for combustion. We have for each 22.42 liters of gas:

TABLE CXXVIII.

COMPOSITION OF PRODUCER AND WATER GASES.

	Composition of Gas in Per Cent by Volume.				Theoretical Amount of Air.		Combustible In- different Gases.		Products of Combustion.		
	H ₂ .	CO.	CO ₂ .	N ₂ .	O ₂ .	N ₂ .			H ₂ O.	CO ₂ .	N ₂ .
1	33½	66¾	16½	64¾	33½	131½	33½	66¾
2	66¾	33½	33½	133½	66¾	166¾	66¾	33½	133½
3	50	50	50	200	100	200	50	50	200

As the decomposition of water requires more heat than is furnished by the formation of CO, and even CO₂, both water gas processes are taking place only with the assistance of external heat. We have

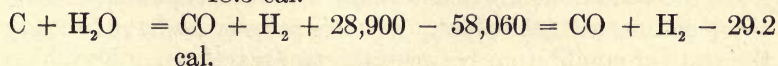
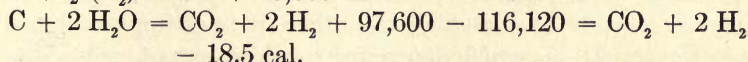

Considering the external heat we have:

	Thermal Value of Gas per 12 Grams C.	External Heat to be Supplied.	Gain in Heat.
$C + \frac{1}{2}(O_2) + 2N_2 = CO + N_2 \dots\dots\dots$	68.7 cal.	-28.9 cal.	97.6
$C + 2H_2O = CO_2 + 2H_2 \dots\dots\dots$	116.1 cal.	+18.5 cal.	97.6
$C + H_2O = CO + H_2 \dots\dots\dots$	126.8 cal.	+29.2 cal.	97.6

The advantage of water gas, therefore, does not consist in a gain in heat, but exclusively in the higher thermal value of this gas, which allows a better utilization in the combustion.

As can be seen from the above statements, the reaction, $C + H_2O = CO + H_2$, will take place if steam is led through a layer of sufficiently hot coal. As heat is absorbed by this reaction, the coal will cool off, and besides the above reaction, the process $C + 2H_2O = CO_2 + 2H_2$ will take place. As the cooling continues the second process will begin to outweigh the first, and finally, since the second reaction also absorbs heat, the coal will be so cold that the reaction will stop, and thus the steam will go through the fuel undecomposed.

This necessitates reheating the coal in the generator. This is done by shutting off the steam and blowing air through the generator until the coal is sufficiently hot. During this period air (generator) gas is produced which can be utilized independent of the water gas. This period is called "hot-blowing." As soon as the coal is hot again, the air blast is stopped and the steam valve opened, and water gas is made until the cooling off of the fire again prevents the rational production of water gas.

We have here, therefore, an intermittent process, which not only requires careful supervision but also the erection of double the number of generators in places where a continuous stream of water gas is required, and where a large gas holder is objectionable.

As we have seen, the two water gas reactions are taking place in parallel. Since, however, the one furnishes a superior gas with better utilization of coal than the other, it is of importance to know the conditions which determine to which extent each of the two reactions will take place. For this purpose we have to study the state of equilibrium between the two reactions.

To find the equilibrium of the gas phase, we have to consider the reactions that are taking place. If we deduct

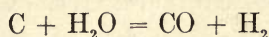

from

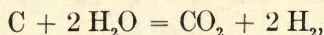

we get

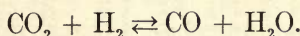

This is a reversible reaction in which two volumes ($CO + H_2O$) are formed from two volumes ($CO_2 + H_2$). It is, therefore, independent of pressure at all temperatures above the boiling point of water. One might now conclude that the composition of water gas at a given temperature is independent of the pressure; this, however, is not correct. From the last equation we get for the isothermic equilibrium

$$K_1 + \frac{C_{CO_2} \cdot C_{H_2O}}{C_{CO_2} \cdot C_{H_2}}, \text{ or } \frac{C_{CO}}{C_{CO_2}} = K_1 \frac{C_{H_2}}{C_{H_2O}}.$$

We therefore see that at a given temperature there is corresponding to every $\frac{CO}{CO_2}$ a different $\frac{H_2}{H_2O}$. To reach definite results we have to look for a reaction which determines the equilibrium between the gas phase (in our case consisting of CO_2 , CO , H_2 and H_2O) and the solid phase (C), and as such we are going to use the equation mentioned already in the generator gas process:

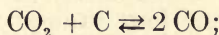

from this equation we have

$$K_2 = \frac{(C_{CO})^2}{C_{CO_2}}.$$

And now the conditions are given for calculating the isothermic equilibrium. As the last-mentioned reaction depends on the pressure, we must necessarily conclude that the composition of water gas also depends on the pressure.

We are going to discuss now the theory of the water gas process in a few words. If we express the steam pressure by P and the gasifying temperature (in degrees C.), by t , the ideal composition of the water gas (*i.e.*, the composition corresponding to the equilibrium reached) is as follows:

TABLE CXXIX.

EFFECT OF STEAM PRESSURE AND TEMPERATURE ON COMPOSITION OF GAS.

Vol. Per Cent.	Steam Pressure, P, in Atmospheres.											
	0.1	0.25	0.5	0.75	1.0	1.5	2.0	2.5	3.0	4.0	5.0	10.0
t = 400° C.												
CO.....	0.24	0.12	0.06	0.04	0.03	0.02	0.02	0.01	0.01	0.01	0.01	0.00
CO ₂	10.88	7.86	5.97	5.04	4.46	3.73	3.27	2.97	2.73	2.40	2.15	1.55
H ₂	21.99	15.84	11.99	10.12	8.94	7.48	6.56	5.94	5.47	4.82	4.31	3.11
H ₂ O.....	66.88	76.18	81.98	84.80	86.57	88.77	90.15	91.08	91.79	92.77	93.53	95.34
t = 600° C.												
CO.....	26.66	18.87	14.65	11.56	10.03	8.14	6.99	6.20	5.61	4.78	4.22	2.87
CO ₂	12.84	16.06	17.15	17.79	17.86	17.67	17.41	17.12	16.84	16.32	15.88	14.32
H ₂	52.34	50.89	48.95	47.14	45.75	43.48	41.81	40.44	39.29	37.42	35.99	31.51
H ₂ O.....	8.16	14.18	19.25	23.51	26.36	30.71	33.79	36.24	38.26	41.48	43.91	51.30
t = 800° C.												
CO.....	49.04	47.81	46.04	44.46	43.05	40.56	38.53	36.83	35.41	32.81	30.69	24.38
CO ₂	0.50	1.13	2.02	2.80	3.48	4.66	5.39	6.34	6.95	8.02	8.88	11.05
H ₂	50.03	50.07	50.08	50.06	50.02	49.88	49.71	49.51	49.21	48.85	48.45	46.48
H ₂ O.....	0.43	0.99	1.86	2.68	3.44	4.90	6.17	7.32	8.43	10.32	11.08	18.09
t = 1000° C.												
CO.....	50.00	50.00	50.00	50.00	50.00	49.42	49.42	49.00	48.57	48.35	47.98	46.24
CO ₂	0.25	0.25	0.45	0.61	0.71	0.87	1.59
H ₂	50.00	50.00	50.00	50.00	50.00	49.92	49.92	49.90	49.79	49.77	49.72	49.42
H ₂ O.....	0.41	0.41	0.65	1.03	1.17	1.43	2.75
t = 1200° C.												
CO.....	50.00	50.00	50.00	50.00	50.00	50.00	50.00	50.00	50.00	49.32	49.31	49.31
CO ₂	0.25	0.25	0.25
H ₂	50.00	50.00	50.00	50.00	50.00	50.00	50.00	50.00	50.00	49.82	49.80	49.80
H ₂ O.....	0.61	0.64	0.64
t = 1400° C.												
CO.....	50.00	50.00	50.00	50.00	50.00	50.00	50.00	50.00	50.00	50.00	50.00	50.00
CO ₂
H ₂	50.00	50.00	50.00	50.00	50.00	50.00	50.00	50.00	50.00	50.00	50.00	50.00
H ₂ O.....

Figs. 87 and 88 show the ideal composition of water gas at a steam pressure of one and four atmospheres. We see from the diagrams that with increasing pressure the curves are moving towards higher temperatures. We also see that the quantity of undecomposed steam present is rapidly decreasing from a certain temperature on, while the quantity of CO and H₂ is rapidly increasing in the same manner. The curves of CO and H₂ are in their middle part practically parallel, but the upward movement of the H-curve is beginning 200° C. below the bend of the CO curve.

The CO₂ curve starts to rise together with the H-curve (but more slowly), until it crosses the steam curve and falls with the latter. The result of this discussion for practice is that the most favorable gasifying temperature is between temperature limits of about 200°, and increases with the steam pressure.

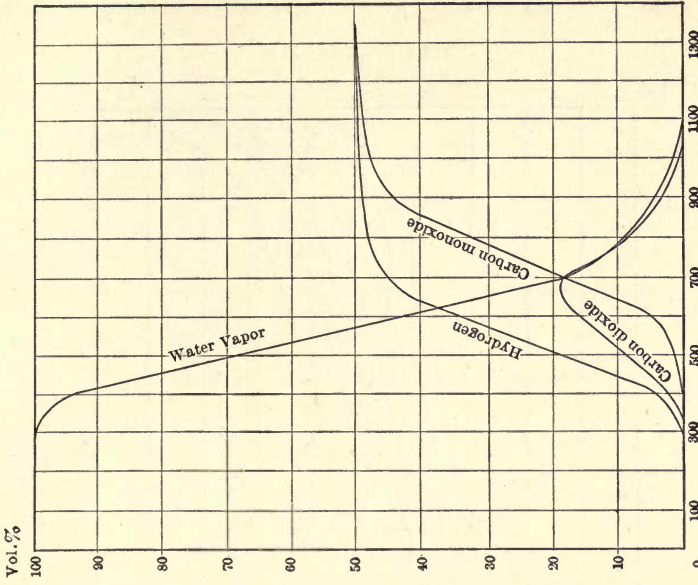

Fig. 88. — Ideal Composition of Water Gas at 3 Steam Pressure of 4 Atmospheres.

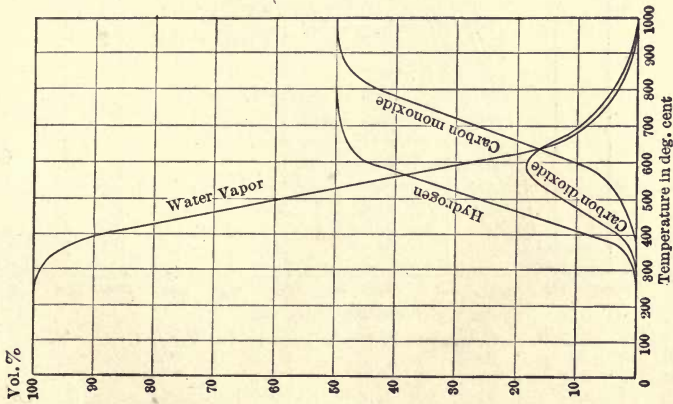

Fig. 87. — Ideal Composition of Water Gas at a Steam Pressure of 1 Atmosphere.

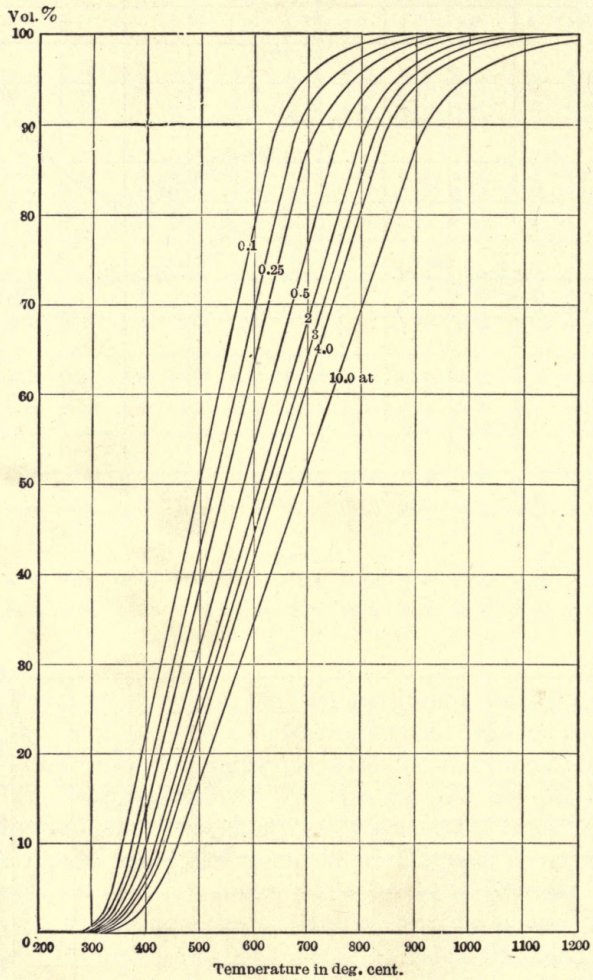

FIG. 89. — Combustible Gases Present in Water Gas.

This becomes clearer when we calculate the quantity of combustible gases (CO and H₂) present in water gas (Fig. 89).

TABLE CXXX.

QUANTITY OF COMBUSTIBLE GASES PRESENT IN IDEAL WATER GAS.

Steam Pressure in Atm.	Gasifying Temperature in Degrees Cent.					
	400	600	800	1000	1200	1400
0.1.....	22.23	79.00	99.07	100.00	100.00	100.00
0.25.....	15.96	69.76	97.88	100.00	100.00	100.00
0.5.....	12.05	63.60	96.12	100.00	100.00	100.00
0.75.....	10.16	58.70	94.52	100.00	100.00	100.00
1.0.....	8.97	55.78	93.08	100.00	100.00	100.00
1.5.....	7.50	51.62	90.44	99.34	100.00	100.00
2.0.....	6.58	48.80	88.24	99.34	100.00	100.00
2.5.....	5.95	46.64	86.34	98.90	100.00	100.00
3.0.....	5.48	44.90	84.62	98.36	100.00	100.00
4.0.....	4.83	42.20	81.66	98.12	99.14	100.00
5.0.....	4.32	40.21	79.14	97.70	99.11	100.00
10.0.....	3.11	34.38	70.86	95.66	99.11	100.00

As the combustion of one mol CO yields 68,600 cal., the combustion of one mol H₂ to liquid water 68,400 cal., which is practically the same amount of heat, we can use the above table for comparing the thermal value of the different gases. As one mol of every gas at 0° and 760 min. pressure occupies a space of 22.42 liters, we can calculate the thermal value of 1 cubic meter of the above gases in large calories by multiplying their content of combustible gases with

$$\frac{1000 \times 68.5}{100 \times 22.42} = 30.6.$$

TABLE CXXXI.

THERMAL VALUE OF 1 CUBIC METER OF IDEAL WATER GAS IN KG. CAL.

Steam Pressure in Atm.	Gasifying Temperature in Degrees Cent.					
	400	600	800	1000	1200	1400
0.1.....	680	2417	3032	3060	3060	3060
0.25.....	590	2135	2995	3060	3060	3060
0.5.....	369	1946	2941	3060	3060	3060
0.75.....	311	1715	2892	3060	3060	3060
1.0.....	274	1707	2848	3060	3060	3060
1.5.....	230	1580	2767	3040	3060	3060
2.0.....	201	1493	2700	3040	3060	3060
2.5.....	182	1427	2642	3026	3060	3060
3.0.....	168	1374	2589	3010	3060	3060
4.0.....	148	1353	2499	2002	3034	3060
5.0.....	132	1230	2422	2990	3033	3060
10.0.....	95	1052	2168	2927	3030	3060

This table shows more clearly that the thermal value of the ideal water gas increases with increasing temperature and decreases with increasing pressure.

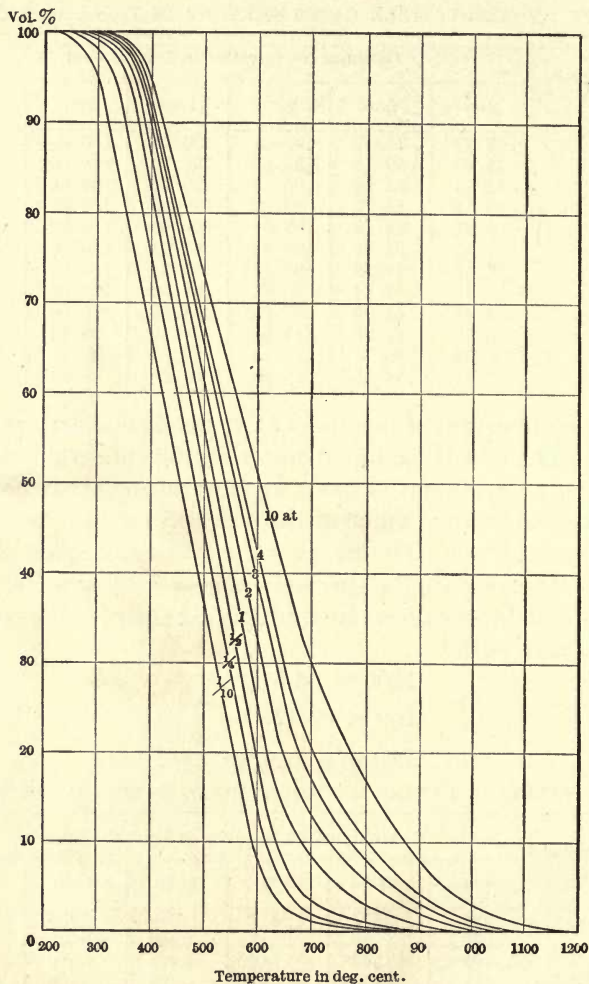

FIG. 90. — Undecomposed Steam in Water Gas.

At a steam pressure of 1 to 2 atmospheres the most favorable gasifying temperature is between 800° and 1000° C., and at 10 atmospheres pressure between 1000° and 1300° C. It is, therefore, not advisable to use steam of too high pressure.

The quality of the water gas is deteriorated by its content of undecomposed steam and of CO_2 . We, therefore, will consider the influence of pressure and temperature on the quantity of H_2O and CO_2 present in the gas.

The quantity of undecomposed steam in the ideal water gas decreases rapidly (Fig. 90) with increasing gasifying temperature and slowly increases with the pressure. As thereby the

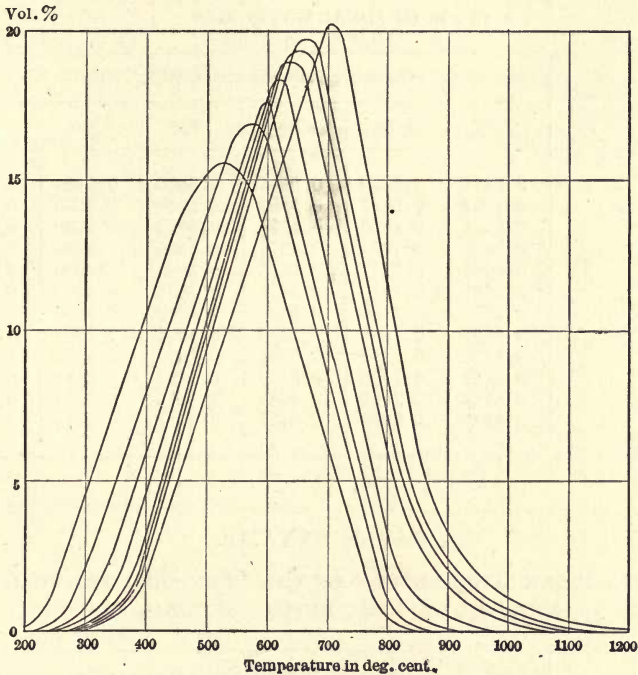

FIG. 91. — CO_2 in Water Gas.

inflammability of the gas is decreased, the gasifying temperature should not be below 700° to 800° C., with a steam pressure of 1 to 10 atmospheres, since otherwise the quantity of undecomposed steam will be considerably above 10 per cent by volume.

The content of CO_2 (Fig. 91) is injurious, as it causes an unfavorable utilization of the carbon. Moreover, it deteriorates the gas, increasing the quantity of non-combustibles and lowering the temperature of combustion. As the CO_2 amounts only to a few per cent at 600° to 700° C., it does not have to be considered in the production of generator gas.

In practice, however, it is of importance to know the quantities of carbon and steam which are required for the formation of 1 cubic meter of water gas. This information is given in the following tables:

TABLE CXXXII.

QUANTITY OF STEAM IN CU. M. REQUIRED FOR THE FORMATION OF
1 CU. M. OF IDEAL WATER GAS.

Steam Pressure in Atm.	Gasifying Temperature in Degrees C.e.t.					
	400	600	800	1000	1200	1400
0.1.....	0.8887	0.6050	0.5046	0.5000	0.5000	0.5000
0.25.....	0.9202	0.6057	0.5106	0.5000	0.5000	0.5000
0.5.....	0.9397	0.6820	0.5194	0.5000	0.5000	0.5000
0.75.....	0.9492	0.7065	0.5274	0.5000	0.5000	0.5000
1.0.....	0.9551	0.7211	0.5346	0.5000	0.5000	0.5000
1.5.....	0.9625	0.7419	0.5478	0.5033	0.5000	0.5000
2.0.....	0.9671	0.7560	0.5588	0.5033	0.5000	0.5000
2.5.....	0.9702	0.7668	0.5683	0.5505	0.5000	0.5000
3.0.....	0.9726	0.7755	0.5764	0.5092	0.5000	0.5000
4.0.....	0.9759	0.7890	0.5917	0.5094	0.5043	0.5000
5.0.....	0.9784	0.7990	0.6043	0.5115	0.5044	0.5000
10.0.....	0.9845	0.8280	0.6457	0.5217	0.5044	0.5000

TABLE CXXXIII.

THEREFORE ONE CUBIC METER OF STEAM FURNISHES THE FOLLOWING
NUMBERS OF CUBIC METERS OF IDEAL GAS.

Steam Pressure in Atm.	Gasifying Temperature in Degrees Cent.					
	400	600	800	1000	1200	1400
0.1.....	1.125	1.653	1.981	2.000	2.000	2.000
0.25.....	1.087	1.537	1.958	2.000	2.000	2.000
0.5.....	1.068	1.466	1.925	2.000	2.000	2.000
0.75.....	1.053	1.415	1.896	2.000	2.000	2.000
1.0.....	1.047	1.386	1.871	2.000	2.000	2.000
1.5.....	1.039	1.348	1.825	1.986	2.000	2.000
2.0.....	1.034	1.323	1.789	1.986	2.000	2.000
2.5.....	1.031	1.304	1.759	1.978	2.000	2.000
3.0.....	1.028	1.289	1.735	1.963	2.000	2.000
4.0.....	1.024	1.269	1.690	1.963	1.983	2.000
5.0.....	1.022	1.251	1.655	1.955	1.982	2.000
10.0.....	1.015	1.208	1.548	1.916	1.982	2.000

The last table is specially valuable for this practice, since it permits an easy control of the operation of the generator and allows the determination of the ideal gasifying temperature, which corresponds to the process. The content of one component of the gas, for instance CO_2 (which can be easily determined with an Ados or Strache apparatus) being known, the complete analysis of the gas can be found.

TABLE CXXXIV.

ONE CUBIC METER OF WATER GAS CONTAINS GRAMS OF C.

Steam Pressure in Atm.	Gasifying Temperature in Degrees Cent.					
	400	600	800	1000	1200	1400
0.1.....	59.51	211.40	265.14	267.60	267.60	267.60
0.25.....	42.71	186.95	261.23	267.60	267.60	267.60
0.5.....	32.27	170.19	257.22	267.60	267.60	267.60
0.75.....	27.19	157.08	252.94	267.60	267.60	267.60
1.0.....	24.03	149.27	249.08	267.60	267.60	267.60
1.5.....	20.07	138.14	242.07	265.83	267.60	267.60
2.0.....	17.61	130.59	236.13	268.83	267.60	267.60
2.5.....	17.05	124.81	231.05	264.66	267.60	267.60
3.0.....	14.66	120.15	226.71	263.21	267.60	267.60
4.0.....	12.90	112.93	218.52	262.57	265.30	267.60
5.0.....	11.56	107.58	211.78	261.45	265.25	267.60
10.0.....	8.30	91.96	189.62	255.99	265.25	267.60

TABLE CXXXV.

ONE CUBIC METER OF STEAM GASIFIES GRAMS OF C. (Fig. 92).

Steam Pressure in Atm.	Gasifying Temperature in Degrees Cent.					
	400	600	800	1000	1200	1400
0.1.....	66.96	349.44	525.44	535.20	535.20	535.20
0.25.....	46.41	287.30	511.61	535.20	535.20	535.20
0.5.....	34.81	249.54	495.23	535.20	535.20	535.20
0.75.....	28.64	222.34	479.59	535.20	535.20	535.20
1.0.....	25.16	207.00	465.92	535.20	535.20	535.20
1.5.....	20.85	186.19	441.89	528.17	535.20	535.20
2.0.....	18.21	172.74	420.77	528.17	535.20	535.20
2.5.....	17.57	162.77	406.54	523.56	535.20	535.20
3.0.....	15.07	154.93	393.32	516.91	535.20	535.20
4.0.....	13.22	143.13	369.31	511.52	526.17	535.20
5.0.....	11.81	134.64	350.45	511.14	525.87	535.20
10.0.....	8.43	115.06	293.67	490.68	525.87	535.20

If the steam of the gas condenses — which frequently happens in practice — the composition and thermal value of the gas changes accordingly. The calculation of the gas composition from the CO_2 content is very simple. The CO_2 of the dry gas being c per cent by volume, the content of

$$\text{CO} = 50 - \frac{3}{2} c \text{ per cent by volume,}$$

$$\text{H}_2 = 50 + \frac{1}{2} c \text{ per cent by volume.}$$

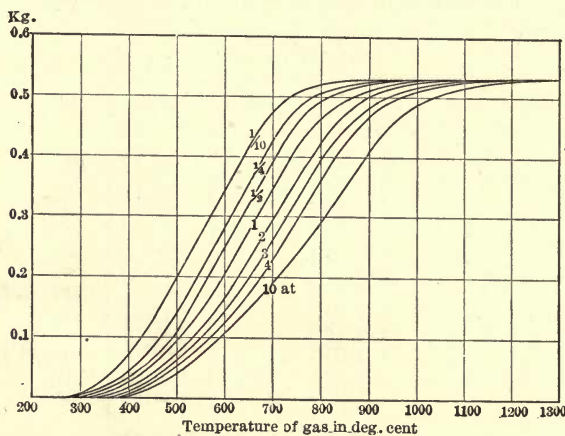

FIG. 92. — Gasification of Carbon by Steam.

For example, we take a gas made at 800°C . and 2.5 atmospheres steam pressure. The CO_2 content having been found as 6.84 per cent by volume, the content of

$$\text{CO} = 50 - 1.5 \times 6.84 = 39.74 \text{ per cent by volume,}$$

$$\text{H}_2 = 50 + 0.5 \times 6.84 = 53.42 \text{ per cent by volume.}$$

The following two tables contain the most important data on dry water gas. Compared with the wet gases, in which at constant pressure the CO_2 content at first increases with the temperature up to a maximum and then decreases, the dry gases have far more regular properties. The CO_2 content at constant pressure decreases with increasing temperature, while CO and H_2 increase simultaneously. On the other hand CO_2 increases at constant temperature with the pressure, while H_2 and CO decrease simultaneously.

TABLE CXXXVI.

QUANTITY OF DRY GAS PRODUCED FROM ONE CUBIC METER OF STEAM.

Steam Pressure in Atm.	One Cubic Meter of Steam is Yielding, at the Temperatures Stated Below, Cubic Meters Dry Water Gas.					
	400° C.	600° C.	800° C.	1000° C.	1200° C.	1400° C.
0.1.....	0.373	1.518	1.972	2.000	2.000	2.000
0.25.....	0.259	1.304	1.939	2.000	2.000	2.000
0.5.....	0.192	1.184	1.889	2.000	2.000	2.000
0.75.....	0.160	1.082	1.845	2.000	2.000	2.000
1.0.....	0.141	1.021	1.807	2.000	2.000	2.000
1.5.....	0.117	0.934	1.736	1.978	2.000	2.000
2.0.....	0.102	0.876	1.679	1.978	2.000	2.000
2.5.....	0.092	0.831	1.630	1.965	2.000	2.000
3.0.....	0.084	0.796	1.589	1.943	2.000	2.000
4.0.....	0.074	0.743	1.516	1.940	1.971	2.000
5.0.....	0.066	0.702	1.457	1.927	1.969	2.000
10.0.....	0.047	0.588	1.268	1.863	1.969	2.000

The most favorable conditions for producing the dry water gas are therefore the same as for the wet gas. We have so far discussed the case in which the state of equilibrium is actually reached in the producer. We are now going to consider the case which is very common in practice, that the equilibrium is not reached.

If steam is blown through a layer of glowing coal the reaction will undoubtedly take place completely on the contact points of steam and coal, *i.e.*, the state of equilibrium will soon be reached here. On its further way the gas current will undergo a change in two respects. Partly by diffusion, partly by mechanical mixture, a reaction will take place between the outer part of the current and the inner part, which is richer in steam; on the other hand, the equilibrium of the outer layer will be disturbed by the contact of same with other parts of the coal.

If the gas passes from the cold to the hot coal layers ("Gegenstrom"), a gas rich in CO_2 will be formed at first in the outer layer; then, by coming in contact with hot coal, it is enabled to oxidize new quantities of coal, getting thereby richer in CO. If, however, the steam passes from the hot to the cold coal layers ("Parallelstrom"), a gas rich in CO will be formed at first in the outer layer, and by passing further it will get richer in CO_2 and poorer in CO.

We will now consider again the reaction between the outer gas layer and the inner steam current. In working according to the "Gegenstrom principle," the steam of the inner surface can react with the outer gas layer, so that CO is oxidized to CO₂ and H₂ is liberated. Supposing the temperature remains constant or decreases, the thermal value of the gas remains unchanged. If, however, the average temperature of the gas current rises — which is probable, since the gas comes into the hotter parts of the producer — this reaction decreases and the actually occurring improvement in the quality of the gas cannot be explained but by oxidation of glowing coal by means of the CO₂ and the steam of the outer layer and also by the outward diffusion of the steam.

If we work according to the "Parallelstrom principle" the hot outer layer formed in the start will react vigorously on the steam (on account of the higher temperature both the diffusion and velocity of reaction will be greater) and the gas without practical change in thermal value will get richer in H₂ and poorer in CO. Hereby the quality of the gas is improved, just the same as above, by the reaction of the outwardly diffusing steam with the glowing coal. On the other hand, the gas quality is deteriorated as the steam gradually comes in contact with cooler coal, whereby the quantity of CO₂ is increased.

Undoubtedly the first mentioned way of gasifying is more advantageous, the more so as in this case the gas and steam current is also preheated gradually.

If we consider the average composition of water gas, in case the state of equilibrium is not reached, we always find this relation between CO₂, CO, and H₂, that the volume of H₂ is equal to the sum of the CO volume and double the CO₂ volume. Besides this some steam is also present. The composition of the wet water gas as well as of the dry gas will, therefore, under all conditions correspond to one equilibrium, which, however, at the same steam pressure corresponds to another (the ideal) gasifying temperature, the latter being lower than the actual gasifying temperature.

Dr. Hugo Strache and R. Jahoda have studied the influence of height of fuel and air and steam velocity on this process, both during hot-blowing and gas making, and have found:

In the beginning of the hot-blowing period (when the temperature of the fuel is rather low) CO₂ is formed almost exclusively

without any CO, while with increasing temperature the formation of CO increases. We have here again the equilibrium which was mentioned before: $2 \text{CO} \rightleftharpoons \text{CO}_2 + \text{C}$.

As less C is absorbed by a certain volume of air for the formation of CO_2 than for the formation of CO, the fuel consumption is considerably less in the first stages of hot-blowing than in the later stage, while the quantity of heat developed per minute is very much greater at the start than in the later stages.

The loss of heat by the hot gas leaving the producer increases with the temperature. The heat accumulated in the producer is evidently equal to the difference of generated and lost heat. The ratio of accumulated heat and carbon used is called by Strache "the efficiency in hot-blowing." This ratio is high in the beginning (at low temperature) and decreases with increasing temperature and fuel consumption.

Content of CO_2 and efficiency in hot-blowing are as follows at

	Efficiency. Per cent.	CO_2 . Per cent.
625° C.	80	18
672° C.	70	16
929° C.	40	7.6
1300° C.	30	4.6

The total efficiency for a certain blowing period decreases rapidly between 650 and 900 degrees; it is therefore advantageous not to raise the temperature of the producer above 900 degrees.

The losses of heat during the hot-blowing period can be utilized to a large extent for preheating the steam (in the manufacture of pure water gas).

The losses during gas making depend on the velocity of steam and the temperature of the producer. Too low velocity yields a rather small quantity of gas and causes comparatively great loss of heat by radiation; too great velocity is disadvantageous on account of the steam going through undecomposed; in this case large quantities of heat leave the producer without being utilized on account of the high specific heat of steam.

The results of these researches are:

1. The quantity of undecomposed steam and the CO_2 content of the gas increase at constant temperature with the increasing velocity of the steam in about the same proportion.
2. The content of steam and CO_2 of the crude gas at constant velocity of steam decreases with increasing temperature.
3. Even at low temperature the content of CO_2 and steam can be reduced to a minimum by decreasing the velocity of steam.

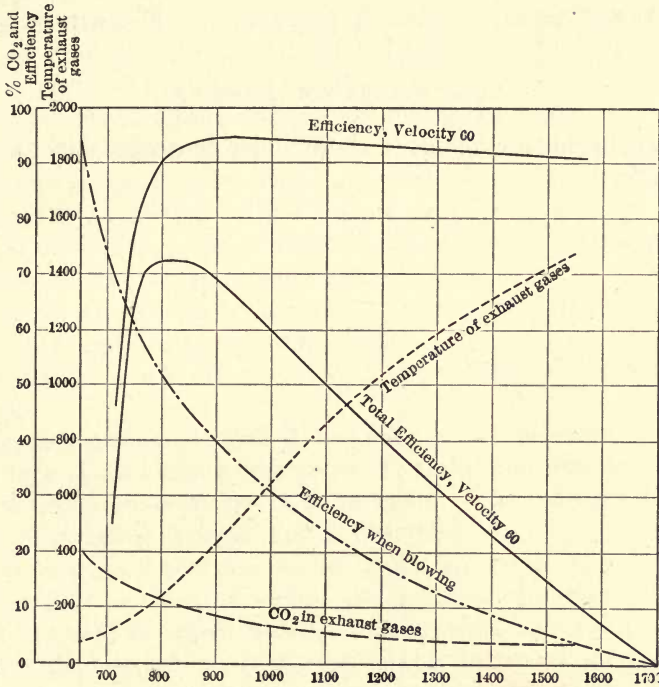

Fig. 93. — Efficiency of Water Gas Making Referred to Velocity of Steam.

The efficiency in gas making is calculated from the carbon consumption during gas making, loss of heat in the producer, and the thermal value of the water gas produced. The total heat loss is made up of the heat of formation, heat of the gas produced and of the undecomposed steam, and the radiation of heat from the producer. For every temperature there is a certain velocity of steam, with which a maximum efficiency is reached (87 to 93 per cent).

The total efficiency for any given velocity of steam can be calculated from the carbon consumption during blowing and gas making and from the loss of heat during blowing and gas making.

Fig. 93 shows a diagram of these conditions.

The total efficiencies also show a maximum at a certain velocity of steam.

At 780° C.....	72.5 per cent,
At 860° C.....	77 per cent.

SUGGESTIONS FOR LESSONS.

Experiments analogous to those under generator (air) gas can be made.

CHAPTER XXII.

DOWSON GAS, BLAST-FURNACE GAS, AND REGENERATED COMBUSTION GASES.

THE production of pure water gas has the advantage of furnishing a gas of high absolute and pyrometric efficiency, which is of importance for certain purposes.

Besides the fact that this gas cannot be generated except by employing external energy (for decomposing steam) and by using an expensive boiler plant, the producer gas which is herein obtained as by-product with a high percentage of carbon dioxide can be used mostly for auxiliary purposes only. Furthermore this process has two disadvantages:

1. It is an intermittent process (two stage), comparatively difficult, complicated, and expensive.
2. It requires a plant of double the size of that of a continuous process.

The idea presented itself of having the two processes of hot-blowing and gas making take place in parallel and simultaneously in one producer, whereby Dowson gas or semi-water gas (sometimes also called producer gas) is obtained.

The purpose of this process being the generation of gas of the highest possible heating value, the amount of carbon dioxide has to be kept as low as possible. Since with decreasing carbon dioxide the nitrogen content considerably increases, the thermal value of the gas decreasing at the same time, this point deserves serious consideration.

We will now consider the ideal conditions. The reaction $C + H_2O = CO + H_2$ takes place with the consumption of 42,900 cal. for every 12 g. of carbon gasified, while in the reaction $C + \frac{1}{2}(O_2) = CO$ 21,100 cal. are liberated for every 12 g. of carbon.

Therefore in order to keep the temperature of the producer constant we have to get as much heat from the second process as is consumed by the first process (not considering the losses of

heat). We therefore have to gasify two atoms of carbon with air for every atom of carbon gasified with steam. The ideal equation for this process is

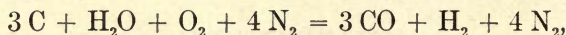

which is equivalent to a Dowson gas of the following composition:

CO.....	37.5
H ₂	12.5
N.....	50.0
	100.00

In the reaction



on the other hand, for every 12 g. of carbon 40,400 cal. have to be furnished by gasifying with air. This is also one atom of carbon gasified with steam to two atoms of carbon gasified with air. The ideal equation is

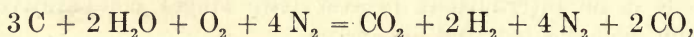

the analysis of the gas:

CO ₂	11.1
CO.....	22.2
H ₂	22.2
N ₂	45.5
	101.0

In working with coal instead of with carbon, volatile matters enter this reaction, whereby the nitrogen content is further decreased.

In practice — on account of unavoidable losses — more than two atoms of carbon have to be gasified with air for every atom gasified with steam.

The equilibrium

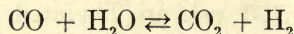

causes the formation of steam, which can considerably deteriorate the quality of the gas.

The principle of this process is the oxidation of carbon partly

by oxygen of the air and partly by oxygen of an oxide (water). A similar reaction takes place in the blast furnace, where, besides the oxygen of the air, the oxygen of the iron oxide is used for oxidizing the carbon mainly according to



and to a small extent according to

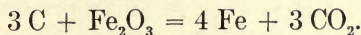

The ordinary composition of blast-furnace gas is

		Average
CO ₂	5-16	12
CO	20-32	24
H ₂	0.1-4.5	2
CH ₄	0.2-2.5	2
N ₂	56-63	60

Blast-furnace gas has a fairly high thermal value. The source of the hydrogen in this gas is the air moisture, which acts on the carbon; the methane content is very probably caused by direct synthesis. Since a considerable part of the oxygen of the blast-furnace gas is derived from the ore instead of the atmosphere, the quantity of nitrogen in furnace gas is lower than in producer gas generated by an exclusive oxidation by means of air. The content of carbon dioxide is partly explained by conditions of equilibrium (in the cooler part of the furnace some of the carbon monoxide is decomposed according to $2 \text{ CO} = \text{CO}_2 + \text{C}$) and partly by the reduction process ($3 \text{ CO} + \text{Fe}_2\text{O}_3 = 3 \text{ CO}_2 + 2 \text{ Fe}$).

Instead of using the oxygen of water or oxides of metals for partly oxidizing carbon, the oxygen of carbon dioxide can be used: $\text{C} + \text{CO}_2 = 2 \text{ CO}$.

This can be done by passing gases rich in carbon dioxide through a glowing layer of coal, which process is called regeneration. Such "regenerable" gases are for instance combustion gases and gases from lime kilns or blast furnaces. The last named gas seems to be especially adapted on account of the small amount of nitrogen present.

If we should succeed in converting by this process the total carbon dioxide of a blast-furnace gas of the above average

analysis into carbon monoxide, a gas of the following composition would be obtained:

$$\begin{aligned} \text{N} &= \frac{60}{1.12} = 53.58 \text{ per cent,} \\ \text{CO} &= \frac{24 + 2 \times 12}{1.12} = 42.86 \text{ per cent,} \\ \text{CH}_4 &= \frac{2}{1.12} = 1.78 \text{ per cent,} \\ \text{H} &= \frac{2}{1.12} = 1.78 \text{ per cent,} \end{aligned}$$

the thermal value of which would be considerably higher than that of the original gas.

The heat consumption for this process is as follows:

The reaction $\text{CO}_2 + \text{C} = 2 \text{CO}$ absorbs $97,600 - 2 \times 26,100 = -45,400$ cal. If we want to reclaim this amount of heat (as with Dowson gas) by the reaction $\text{C} + \text{O} = \text{CO} + 21,100$ cal., we have to transform for every mol of carbon dioxide contained in the gas $\frac{45.4}{21.1}$ or about 2 atoms of carbon into air-producer gas.

We get about the same conditions as with water gas, and in practice we will have to burn, instead of 2 mols carbon, from 3 to 5 mols to carbon monoxide. Supposing we should get 2 mols of carbon monoxide by direct combustion, for every mol of carbon dioxide, we would have the following theoretical composition for the regenerated blast-furnace gas:

$$\begin{aligned} \text{N} &= \frac{60 + 45.14}{1.81} = 58.06 \text{ per cent,} \\ \text{CO} &= \frac{24 + 4 \times 12}{1.81} = 39.74 \text{ per cent,} \\ \text{CH}_4 &= \frac{2}{1.81} = 1.10 \text{ per cent,} \\ \text{H}_2 &= \frac{2}{1.81} = 1.10 \text{ per cent.} \end{aligned}$$

As above stated a larger part of the carbon will have to be burned in practice on account of unavoidable losses in heat.

Supposing we take 3 gram-atoms of carbon for every mol of dioxide to be reduced, we get a gas of the following theoretical composition:

$$N = \frac{60 + 67.71}{2.16} = 59.21 \text{ per cent,}$$

$$CO = \frac{24 + 36 + 24}{2.16} = 38.93 \text{ per cent,}$$

$$CH_4 = \frac{2}{2.16} = 0.93 \text{ per cent,}$$

$$H_2 = \frac{2}{2.16} = 0.93 \text{ per cent.}$$

In practice this result could be obtained only by applying a sufficiently high gasifying temperature, as otherwise the reaction would be incomplete. So far this method is not in practical use.

SUGGESTIONS FOR LESSONS.

Production of Dowson gas, same as in the two former lessons.

Effect of air and carbon dioxide upon a layer of glowing coal.

CHAPTER XXIII.

APPARATUS FOR THE PRODUCTION OF FUEL GASES.

(GENERATOR OR PRODUCER GAS PLANTS.)

THE apparatus which are used in practice for manufacturing fuel gases are called gas-generators or gas-producers. These are, generally speaking, chambers lined with firebrick. These chambers are charged with coal, wood or peat respectively, and the air of combustion or steam or a mixture of steam and air is passed through, generally upward.

If air (generator) gas is produced the gas in the producer is moved either by draft (chimney) alone or by pressure (blower). Accordingly we have a classification in draft and pressure-producers. The latter have to be closed tight at the bottom.

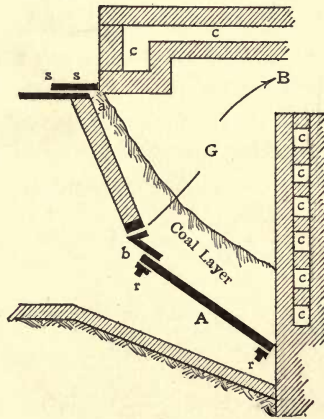
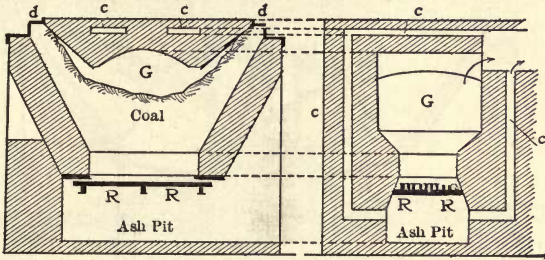

FIG. 94. — Boetius Gas Generator.

We shall consider first the air-gas generators, which were built originally right near the furnace, which was to be heated (Siemens gas or half-gas). Their development is shown by the following types:

Fig. 94. Boetius producer. The producer compartment, *G*, is separated from the combustion chamber of the furnace by a vertical wall and from the outside atmosphere by an inclined wall upon which the charged coal slides down. The opening, *a*, for the charge can be closed by means of the slide, *ss*. The inclined wall is supported by the iron bar, *b*, which contains an



Figs. 95 and 96. — Boetius Double Generator.

opening for poking and air-admission. At the bottom the producer compartment, *G*, is separated from the ashpit, *A*, by the inclined grate, *r*. The channels, *c*, in the back wall allow a preheating of the air of combustion.

Figs. 95 and 96. Boetius double producer, developed from the former type by combining two producers (right and left)

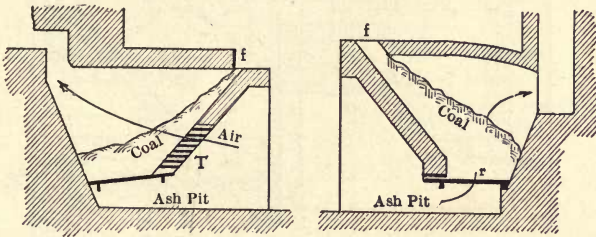

Figs. 97 and 98. — Bicheroux Generators.

and leaving out the back walls. Thereby less brickwork is required and loss by radiation from the back wall avoided (at the same time doing away with the preheating of air). We find here the air-channels in the side walls. The inclined grate is supplanted by a plane-grate. *R* is the grate, *c* the air-channels.

Larger than these are the Bicheroux producers (Figs. 97 and 98) which are provided either with step-grate, *T*, and inclined

grate, *R*, or with a plane-grate, *r*. *f* is the charging opening. These producers are also built right near the fireplace.

Largely used are the shaft producers of William and Friedrich Siemens. They are built independent of the furnace to be

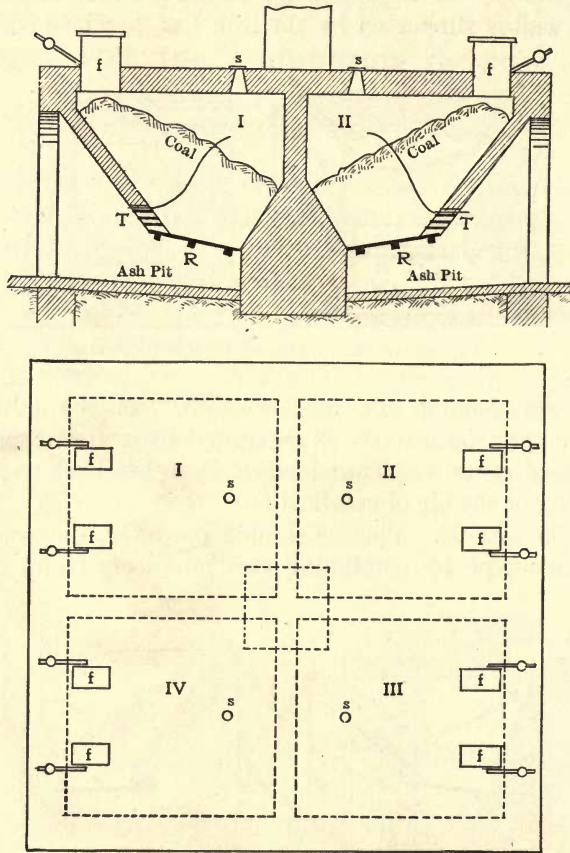

FIGS. 99 and 100. — Siemens Generator.

heated. In order to avoid as far as possible losses of heat and to save brickwork they are frequently built below the floor level in rows or in squares. Figs. 99 and 100 show a plant of the latter kind in elevation and ground plan. Fig. 99 shows two producers with one common wall. These producers are provided with step-grates, *T*, and inclined grate, *R*. The ground plan shows four producers I, II, III and IV, arranged in the form of a square.

There are two charging chutes for each producer; the holes, *s*, are for poking the fire. The gas leaves all four producers through one gas main. The back wall of these producers is inclined, for preventing the air from passing along the vertical wall (least resistance).

A charging hopper is shown in Fig. 101. Same is provided with a valve operated by a counterweight and a cover which

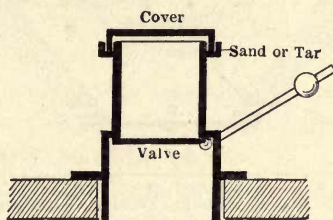

FIG. 101. — Charging Hopper.

closes gas-tight by means of a sand or tar seal. For charging coal the cover is removed, coal filled in, the cover put on and then the valve opened. Thereby losses of gas are prevented.

In order to increase the fuel height, *C*, which is to be measured in the direction of the arrows, in some cases the charging hopper

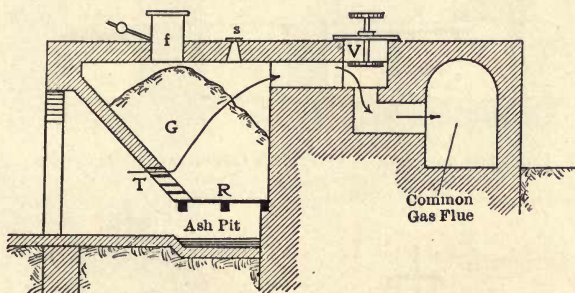

FIG. 102. — Siemens Generator of Neuberg.

has been moved more toward the center (Fig. 102). For disconnecting one producer of a producer system, valves, *V*, are provided. Below the ash-pit there is an excavation filled with water, the latter being evaporated by the ash and fuel falling through the grate, whereby the quality of the gas is improved (Dowson gas).

If we omit one of the two separating walls in a square of

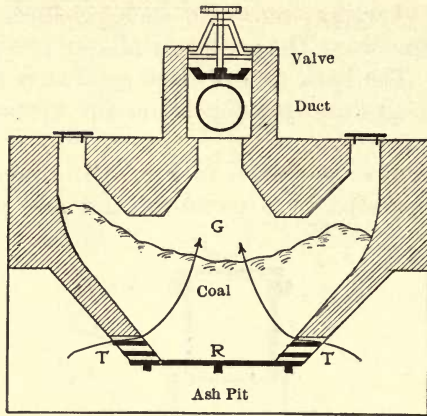
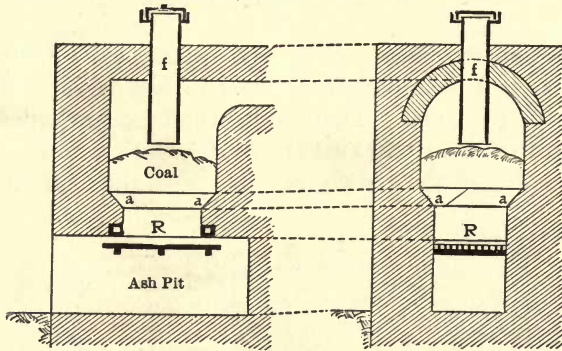

FIG. 103. — Siemens Double Generator.



FIGS. 104 and 105. — Old Shaft Generator of Donawitz.

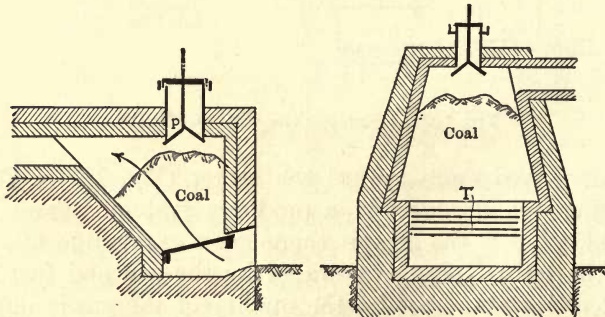

FIG. 106. — Generator of Kolsva.

FIG. 107. — Bituminous Coal Generator of Odelstjerna.

four Siemens producers, we arrive at double producers (Fig. 103) which can be built singly or in rows.

Shaft producers (old Donawitz type) for lignite and brown coal are shown in Figs. 104 and 105. The inclined step, *a*, in the brick lining is necessary for preventing the rising of the air alongside the walls. Other types of shaft producers are:

The producer of Kolsva in Sweden (Fig. 106) in which Parry's hopper, *p*, is used for charging.

The different types of producers of Odelstjerna are:

(*a*) For bituminous coal (Fig. 107). This producer is wider at the bottom to facilitate the downward movement of the coal. For preventing the rising of the air alongside the wall an offset is arranged at the bottom of the shaft.

(*b*) For peat, wood and shavings (Fig. 108). For these fuels the shaft has to be considerably wider and the fuel-height

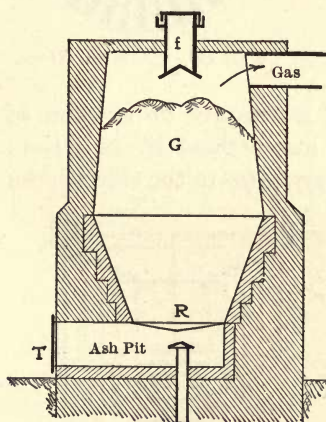

FIG. 108. — Odelstjerna's Generator for Peat, Wood and Shavings.

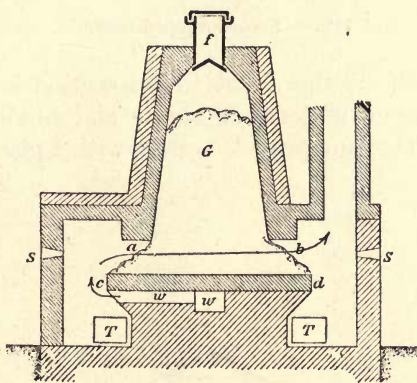

FIG. 109. — Generator of Tholander.

greater than for coal. A plane or step-grate is used in these producers, which are generally arranged for blast and provided with air-tight doors, *T*. The soft coal producer of Tholander (Fig. 109), which is of peculiar shape, is arranged for air blast at the bottom. In this construction the active height of fuel (*i.e.* the way along which the primary air comes in contact with glowing coal, *ab*) is kept constant at all periods. The fuel rests on a solid base, *cd*. *F* is the charging hopper, *w* is the blast-channel, *G* the

producer-shaft, *ss* are the poke-holes and *TT* the ash-doors. As seen from the above descriptions the cross-sections of producers are made both square and circular. In single (isolated) pro-

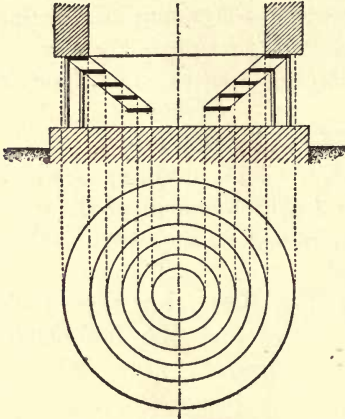

FIG. 110. — Funnel-Shaped Grate.

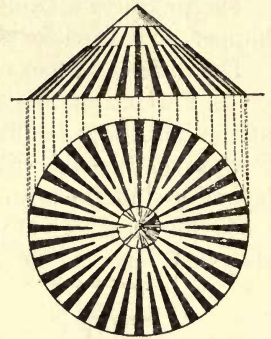

FIG. 111. — Conical Grate.

ducers the circular cross-section is of advantage on account of more uniform operation and smaller loss of heat by radiation. They are provided either with a plane-grate (as in the Odelstjerna

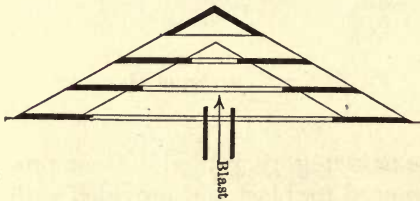

FIG. 112. — Conical Grate.

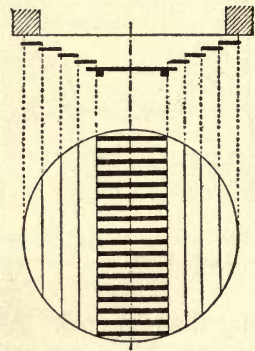

FIG. 113. — Bottom of Generator with Step and Plane Grate.

type for peat, wood, etc.), or with a funnel-shaped or conical grate (Figs. 110, 111 and 112).

Less advantageous is the combined use of two step-grates and one plane-grate (Fig. 113).

Plane-grates can be used only for large-size fuels as fuel of small grain would fall through the grate-bars. Step-grates have to be used for the latter fuel. In many cases the Lichtenfel's construction of plane and step-grates is convenient, which combines the good points of plane and step-grates (Fig. 114). The

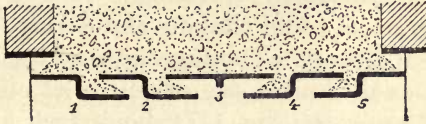
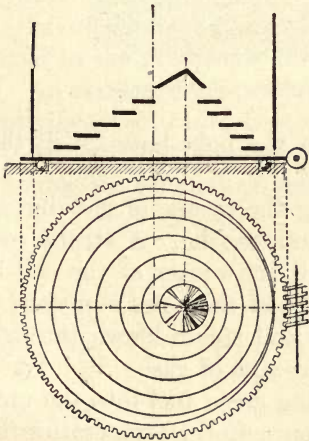

FIG. 114. — Lichtenfel's Plane Step Grate.

trouble of cleaning the grate is reduced to a minimum if the grate-bars 1, 3 and 5 are arranged unmovable while 2 and 4 are kept in motion at a right angle to the elevation of the producer, as thereby most of the ash falls through automatically.



FIGS. 115 and 116. — Turnable Eccentric Cone-Grate.

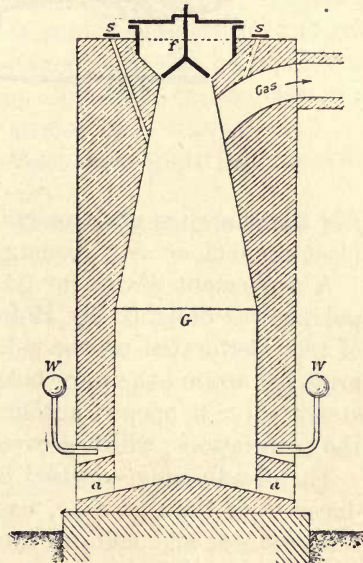

FIG. 117. — A. Sailer's Pressure Producer with Slag Openings.

The same effect is reached by revolving conical-grates, especially if the axis of rotation and axis of the cone are not the same (Figs. 115, 116). Such an eccentric cone-grate can be mounted upon a circular base-plate, which moves in a channel.

If the plate is provided with teeth around the edge it can be driven by a simple worm gear.

On the other hand some rather complicated stirring-arrangements have been put on circular producers.

In pressure producers a grate is not an absolute necessity, as we have seen on Tholander's producer. It is of advantage to work without grate, if badly clinking and coking fuel is used, in which case it is frequently advantageous to add a flux to the fuel for forming an easily fusible slag, which is let off from time to time. Saillers' producer (Fig. 117) shows such a construction.

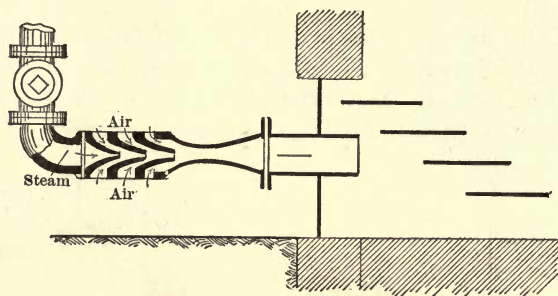

Fig. 118. — Steam Jet-Blower for Dowson Gas Generator.

f is the charging arrangement, *ss* are the poke-holes, *WW* the blast channel, *aa* slag openings.

A convenient device for preventing the escape of gas during poking was designed by Hofmann and Stache. A steam coil of pipe perforated on the side toward the center of the coil is arranged around the poke-hole. If one of the holes is opened a steam valve is opened automatically and steam blown through the perforations, which prevents the escape of gas.

The disadvantages caused by putting green fuel into the producer from time to time, namely non-uniform temperature of the producer and uniform composition of the gas, was the reason for experiments to separate the process of distillation from the process of gasification. Such suggestions were made by Minary, Brook and Wilson, Kleeman, C. Neese, Groebe-Lührmann, Wilhelm Schmidhammer, Fr. Toldt, etc. All these producers are rather complicated and better result can be obtained more conveniently by combining a number of producers.

The manufacture of Dowson gas in draft-producers is effected

by arranging a water-basin below the grate. By the radiating heat of the grate-bars and the hot ash falling through, water is evaporated and with the air carried through the producer.

In pressure producers air and steam are either led under the grate separately (which allows independent regulation of air and gas) or a steam jet-blower is used, which draws in the air (Fig. 118).

The condensation of the products of distillation in the producer gas by cooling and washing is, under ordinary conditions, uneconomical, as both by cooling and condensation considerable quantities of heat are lost.

The apparatus for producing pure water-gas will be considered later.

SUGGESTIONS FOR LESSONS.

A producer gas plant is to be designed for a certain amount of heat required per hour and a fuel of known composition and gas-yield. Herein secondary circumstances can also be considered (plan of the floor space at disposal, convenient transportation of coal to the producers, reserve-producers, coal storage, etc.).

An existing draft-producer plant is to be changed into pressure-producers or into a Dowson-gas plant.

An existing producer plant is to be enlarged, so as to yield double the amount of gas.

INDEX

- Absorbing capacity of coals, 199.
Air, surplus, for combustion, 258.
Alloys —
 melting points of, 54.
 Princep's, 53.
Ammonia available in coals, 222.
Analysis of —
 anthracites, 186.
 ash, 151.
 bituminous coal, 184, 185.
 brown coal, 173.
 brown coal-ash, 177.
 peat, 168, 171.
 producer gas, 256.
 products of destructive distillation, 216, 217.
Anthracites, analysis of, 186.
Arth's formula, 115.
Artificial fuels —
 gaseous, 243.
 solid, 143, 188.
Ash —
 analyses, 151.
 content of peat, 169.
 of wood, 149, 150.

Berthier's method, 111.
Bessemer converter, temperature in, 72.
Bituminous coal —
 analysis, 184, 185.
 classification, 178.
 destructive distillation, 215.
 generating gas from, 265.
Blast furnace —
 gas, 287.
 temperature in, 72.
Boiling and melting points, 51.
Briquettes, 228.
 composition of lignite, 229.

Brown coal —
 analysis, 173.
 ash, 177.
 classification, 174.

Calculation of thermal values, 110.
Calibrating pyrometers, 83.
Calorimeter —
 Fischer, 64, 93.
 Mahler, 94.
 Parr, 100, 104.
 Weinhold, 61.
Carbon dioxide, dissociation of, 120.
Carbonaceous decomposition, 156.
Charcoal, 191.
 absorbing capacity, 199.
 classification, 199.
 composition, 192.
 temperature of ignition, 199.
 weight, 198.
Charring, 193.
 with steam, 208.
 yield of, 194-196.
Classification —
 charcoal, 199.
 coal, 174, 178, 180.
 fuel, 141.
 peat, 166.
 wood, 145.
Coal —
 ammonia available, 222.
 yield from destructive distillation of, 221.
Coke oven —
 Coppée, 235.
 François, 235.
 François-Rexroth, 233.
 Dr. Otto, 235.
 gas, 223.
 Smet, 233.
 tar, 222.

- Coking apparatus, 231.
- Combustion —
 data, 130.
 gases, regenerated, 287.
 heat, 91, 105, 108.
 incomplete, 117.
 of producer gas, 139.
 products of, 262.
 surplus air for, 258.
 temperature of coal, 136.
 of producer gas, 138.
- Composition —
 of coals, 221.
 of fuels, 142, 157, 160.
 of Kiln gases, 204.
 of peat, 169.
 of products of destructive distillation, 190.
 of wood, 148.
- Cones —
 composition of, 57, 58.
 melting points of, 56.
 Seger, 55.
- Content of wood, actual, 147.
- Coppée oven, 235.
- Crony oven, 237.
- Data on charring, 193.
- Decomposition, carbonaceous, 156.
- Depression of glass, 38.
- Destructive distillation —
 analysis, 216, 217.
 effect of admixtures, 220.
 of coal, composition of products of, 190.
 of coal, yield from, 221.
 of bituminous coal, 215.
 of peat, 214, 224, 225, 226.
- Determination of thermal value, 92.
- Dissociation of carbon dioxide, 120.
- Distillation, products of, 262.
- Distribution of heat, 263.
- Dowson gas, 287.
- Economy of operation, 8.
- Elementary composition of coal and products of combustion, 262.
 distillation, 262.
- Elementary composition of producer gas, 257.
- Emissive power of substances, 73.
- Energy —
 changes of, 12.
 chemical, change of, 26.
 distance, 14.
 electric, 27.
 forms of, 13.
 of reaction, 24.
 radiant, 30.
 radiation of, 78.
 surface, 16.
 volume, 25.
- Errors in the measurement of temperatures, 38.
- Evaporating power of wood, 153.
- Explosives, 124.
- External work, 132.
- Féry's thermoelectric telescope, 79.
- Fischer calorimeter, 64, 93.
- Formula —
 Arth, 115.
 Gmelin, 112.
 Goutal, 116.
- François oven, 235.
- François-Rexorth oven, 233.
- Fuels —
 artificial solid, 143.
 classification of, 141.
 composition of, 142, 157, 160.
 formation heat of, 161.
 liquid, 241.
 composition of, 241, 242.
 natural solid, 142.
 thermal efficiency of, 242.
- Fuel gases —
 production of, 244.
 value of wood, 153.
- Furnace, ideal, 128.
- Gas, producer, 246.
 analysis, 256.
 elementary components, 257.
 influence of temperature in the manufacture of, 247.
 ideal composition of, 249, 250, 251.

- Gases —
 combustion temperature, 135.
 mixed distillation and combustion, 261.
 specific heat, 129.
- Gasifying temperature, 259.
- Generator —
 gas from bituminous coal, 265.
 lignite, 266.
 peat, 265.
 wood, 264.
 gas plants, 292.
 heat distribution in, 263.
- Glass, standard thermometer, 39.
- Glow colors —
 temperatures corresponding to, 69.
 of silver, 71.
- Gmelin's method, 112.
- Goutal's formula, 116.
- Grates —
 for producers, 297, 298.
 Lichtenfels', 298.
- Hartmann and Braun's pyrometer, 81.
- Heat —
 capacities, 66.
 combustion, 91.
 distribution, 263.
 of combustion products, 138.
- Ideal furnace, 128.
- Illuminating flames, 123.
- Illuminating gas, 223.
- Incomplete combustion, 117.
- Increase of value of a substance, 7.
- Kiln gases, composition of, 204.
- Klinghammer's thalpotasimeter, 52.
- Law —
 Joule's, 30.
 Ohm's, 29.
- Lichtenfels' grate, 298.
- Light, intensities of, 74.
- Lignite briquettes, composition of, 229.
- Liquid fuels, 241.
 composition of, 241, 242.
- Lottmann oven, 237.
- Mahler's calorimeter, 94.
- Measurements —
 pyrometrical, 80, 81.
 with thermolements, 82.
- Melting point —
 of alloys, 54.
 of metals, 60.
- Mixed distillation and combustion gases, 261.
- Moisture in wood, 150, 151.
- Natural gas, composition, 243.
- Natural solid fuels, 142.
- Odelstjerna producer, 297.
- Optical methods of measuring temperatures, 68.
- Otto oven, 235.
- Oven, pile retort, 212.
- Parr, calorimeter, 100, 104.
- Peat —
 analysis, 168, 171.
 ash content, 169.
 classification, 166.
 coke ovens, 237.
 composition, 169.
 destructive distillation, 214, 224, 225, 226.
 generator gas, 265.
 thermal value, 170.
- Pile oven, 206.
- Piles, 202.
- Poking producers, 300.
- Potential, chemical, 22.
- Princep's alloys, 53.
- Producers —
 grates, 297, 298.
 Odelstjerna, 297.
 poking, 300.
 Siemens, 294.
 Tholander, 297.
- Producer gas, 246.
 analysis, 256, 269.
 elementary components, 257.
 ideal composition of, 249, 250, 251.
 influence of temperature in the manufacture of, 247.
 plants, 292.

- Production of fuel gases, 244.
- Pyrometer —
 calibrating, 83.
 of Cornu Le Chatelier, 73.
 of Hartmann and Braun, 81.
 of Mesuré and Nouel, 68.
 of Wanner, 75.
 of Weinhold, 61.
 polariscopic, 71.
 water (Siemens), 67.
- Pyrometrical measurements, 80, 81.
- Pyroscopes, composition, 57, 58.
- Resin content of wood, 149.
- Seasoning of wood, 152.
- Seeger cones, 55.
 composition of, 57, 58.
 melting points of, 56.
- Siemens' producer, 294.
 water pyrometer, 67.
- Smelting furnace, 123.
- Smet oven, 233.
- Solid substances, combustion temperature of, 135.
- Specific gravity of woods, 145, 146.
- Specific heat of gases, 129.
- Superheated steam for charring, 208.
- Tar from coke ovens, 222.
- Temperatures —
 corresponding to glow colors, 69.
 determination, 75, 77, 86.
 gasifying, 259.
 measurement of high, 37.
 of ignition of charcoal, 199.
 optical methods of measuring, 68.
- Thalpotasimeter, 52.
- Thermal value —
 Berthier's method for determining, 111.
 calculation, 110.
 direct determination, 92.
 Gmelin's method, 112.
 of peat, 170.
 of wood, 152.
- Thermodynamic laws, 19.
- Thermoelectric telescope, 79.
- Thermoelements, 85.
 measurements with, 82.
- Thermometers, 37.
 correction factors, 40.
 gas or air, 43.
 reading of, 39.
- Thermophone, 87.
- Tholander's producer, 297.
- Vignoles' oven, 237.
- Wanner pyrometer, 75.
- Water gas, 268.
 carbon content, 279.
 combustible gases in, 275.
 composition of, 269.
 effect of steam pressure and temperature, 272, 282.
 equilibrium, 271.
 quantity of steam required for formation of, 278, 281.
 theory of, 283.
 thermal value of, 275.
- Weight of wood, 148.
- Weinhold's pyrometer, 61.
- Wiborgh's thermophone, 87.
- Wood, 145.
 actual content of, 147.
 ash content of, 149, 150.
 classification of, 145.
 composition of, 148.
 distillation of, 191.
 evaporating power of, 153.
 generator gas from, 264.
 moisture in, 150, 151.
 resin content of, 149.
 seasoning, 152.
 specific gravity of, 145, 146.
 thermal value, 152, 153.
 weight of, 148.
- Work, external, 132.
- Yield from destructive distillation of coals, 221.



The Mechanical Appliances OF THE Chemical and Metallurgical Industries

BY OSKAR NAGEL, PH.D.

A Detailed Description of all Machines, Appliances and Apparatus Used in the Chemical and Metallurgical Industries.

THE ONLY AMERICAN BOOK ON THIS SUBJECT

CONTENTS

I. General. II. Steam and Water Power. III. Gas Power. IV. Electric Power. V. Transportation of Solids. VI. Transportation of Liquids. VII. Transportation of Gases. VIII. Grinding Machinery. IX. Mixing Machines. X. Firing and Furnaces. XI. Separating Machines. XII. Purification of Gases. XIII. Evaporating, Distilling and Condensing. XIV. Drying.

300 Pages 8vo. 292 Illustrations

Price, \$2.00

Sent Anywhere on Receipt of Price

OSKAR NAGEL

P. O. Box 385

NEW YORK

work
used

TP318
 J8
 mining
 dept.

181331

Gipstner

